

STIHL®

STIHL HSE 61, 71, 81

Gebrauchsanleitung
Instruction Manual
Notice d'emploi
Manual de instrucciones

Skótselanvisning
Käyttöohje
Istruzioni d'uso
Betjeningsvejledning
Bruksanvisning
Használati utasítás
Instruções de serviço
Handleiding
οδηγίες χρήσης
Instrukcja użytkowania



- Ⓓ **Gebrauchsanleitung**
1 - 21
- ⒼⒷ **Instruction Manual**
22 - 41
- Ⓕ **Notice d'emploi**
42 - 63
- Ⓔ **Manual de instrucciones**
64 - 85
- Ⓐ **Skötselanvisning**
86 - 105
- ⒻⒼ **Käyttöohje**
106 - 125
- Ⓘ **Istruzioni d'uso**
126 - 146
- ⒹⓀ **Betjeningsvejledning**
147 - 166
- Ⓐ **Bruksanvisning**
167 - 186
- Ⓕ **Használati utasítás**
187 - 207
- Ⓐ **Instruções de serviço**
208 - 229
- ⒶⓁ **Handleiding**
230 - 251
- ⒼⓇ **οδηγίες χρήσης**
252 - 273
- ⒶⓁ **Instrukcja użytkowania**
274 - 296

- c) **Halten Sie Elektrowerkzeuge von Regen oder Nässe fern.** Das Eindringen von Wasser in ein Elektrowerkzeug erhöht das Risiko eines elektrischen Schlages.
- d) **Zweckentfremden Sie das Kabel nicht, um das Elektrowerkzeug zu tragen, aufzuhängen oder um den Stecker aus der Steckdose zu ziehen. Halten Sie das Kabel fern von Hitze, Öl, scharfen Kanten oder sich bewegenden Geräteteilen.** Beschädigte oder verwickelte Kabel erhöhen das Risiko eines elektrischen Schlages.
- e) **Wenn Sie mit einem Elektrowerkzeug im Freien arbeiten, verwenden Sie nur Verlängerungskabel, die auch für den Außenbereich geeignet sind.** Die Anwendung eines für den Außenbereich geeigneten Verlängerungskabels verringert das Risiko eines elektrischen Schlages.
- f) **Wenn der Betrieb des Elektrowerkzeuges in feuchter Umgebung nicht vermeidbar ist, verwenden Sie einen Fehlerstromschutzschalter.** Der Einsatz eines Fehlerstromschutzschalters vermindert das Risiko eines elektrischen Schlages.
- 3) Sicherheit von Personen**
- a) **Seien Sie aufmerksam, achten Sie darauf, was Sie tun, und gehen Sie mit Vernunft an die Arbeit mit einem Elektrowerkzeug. Benutzen Sie kein Elektrowerkzeug, wenn Sie müde sind oder unter dem Einfluss von Drogen, Alkohol oder Medikamenten stehen.** Ein Moment der Unachtsamkeit beim Gebrauch des Elektrowerkzeuges kann zu ernsthaften Verletzungen führen.
- b) **Tragen Sie persönliche Schutzausrüstung und immer eine Schutzbrille.** Das Tragen persönlicher Schutzausrüstung, wie Staubmaske, rutschfeste Sicherheitsschuhe, Schutzhelm oder Gehörschutz, je nach Art und Einsatz des Elektrowerkzeuges, verringert das Risiko von Verletzungen.
- c) **Vermeiden Sie eine unbeabsichtigte Inbetriebnahme. Vergewissern Sie sich, dass das Elektrowerkzeug ausgeschaltet ist, bevor Sie es an die Stromversorgung und/oder den Akku anschließen, es aufnehmen oder tragen.** Wenn Sie beim Tragen des Elektrowerkzeuges den Finger am Schalter haben oder das Gerät eingeschaltet an die Stromversorgung anschließen, kann dies zu Unfällen führen.
- d) **Entfernen Sie Einstellwerkzeuge oder Schraubenschlüssel, bevor Sie das Elektrowerkzeug einschalten.** Ein Werkzeug oder Schlüssel, der sich in einem drehenden Geräteteil befindet, kann zu Verletzungen führen.
- e) **Vermeiden Sie eine abnormale Körperhaltung. Sorgen Sie für einen sicheren Stand und halten Sie jederzeit das Gleichgewicht.** Dadurch können Sie das Elektrowerkzeug in unerwarteten Situationen besser kontrollieren.
- f) **Tragen Sie geeignete Kleidung. Tragen Sie keine weite Kleidung oder Schmuck. Halten Sie Haare, Kleidung und Handschuhe fern von sich bewegenden Teilen.** Lockere Kleidung, Schmuck oder lange Haare können von sich bewegenden Teilen erfasst werden.
- g) **Wenn Staubabsaug- und -auffangeinrichtungen montiert werden können, vergewissern Sie sich, dass diese angeschlossen sind und richtig verwendet werden.** Verwendung einer Staubabsaugung kann Gefährdungen durch Staub verringern.
- 4) Verwendung und Behandlung des Elektrowerkzeuges**
- a) **Überlasten Sie das Gerät nicht. Verwenden Sie für Ihre Arbeit das dafür bestimmte Elektrowerkzeug.** Mit dem passenden Elektrowerkzeug arbeiten Sie besser und sicherer im angegebenen Leistungsbereich.
- b) **Benutzen Sie kein Elektrowerkzeug, dessen Schalter defekt ist.** Ein Elektrowerkzeug, das sich nicht mehr ein- oder ausschalten lässt, ist gefährlich und muss repariert werden.

- c) **Ziehen Sie den Stecker aus der Steckdose und/oder entfernen Sie den Akku, bevor Sie Geräteeinstellungen vornehmen, Zubehörteile wechseln oder das Gerät weglegen.** Diese Vorsichtsmaßnahme verhindert den unbeabsichtigten Start des Elektrowerkzeuges.
- d) **Bewahren Sie unbenutzte Elektrowerkzeuge außerhalb der Reichweite von Kindern auf. Lassen Sie Personen das Gerät nicht benutzen, die mit diesem nicht vertraut sind oder diese Anweisungen nicht gelesen haben.** Elektrowerkzeuge sind gefährlich, wenn sie von unerfahrenen Personen benutzt werden.
- e) **Pflegen Sie Elektrowerkzeuge mit Sorgfalt. Kontrollieren Sie, ob bewegliche Teile einwandfrei funktionieren und nicht klemmen, ob Teile gebrochen oder so beschädigt sind, dass die Funktion des Elektrowerkzeuges beeinträchtigt ist. Lassen Sie beschädigte Teile vor dem Einsatz des Gerätes reparieren.** Viele Unfälle haben ihre Ursache in schlecht gewarteten Elektrowerkzeugen.

- f) **Halten Sie Schneidwerkzeuge scharf und sauber.** Sorgfältig gepflegte Schneidwerkzeuge mit scharfen Schneidkanten verklemmen sich weniger und sind leichter zu führen.
- g) **Verwenden Sie Elektrowerkzeug, Zubehör, Einsatzwerkzeuge usw. entsprechend diesen Anweisungen.** Berücksichtigen Sie dabei die **Arbeitsbedingungen und die auszuführende Tätigkeit.** Der Gebrauch von Elektrowerkzeugen für andere als die vorgesehenen Anwendungen kann zu gefährlichen Situationen führen.

5) Service

- a) **Lassen Sie Ihr Elektrowerkzeug nur von qualifiziertem Fachpersonal und nur mit Original-Ersatzteilen reparieren.** Damit wird sichergestellt, dass die Sicherheit des Elektrowerkzeuges erhalten bleibt.

Sicherheitshinweise für Heckenscheren

- **Halten Sie alle Körperteile vom Schneidmesser fern. Versuchen Sie nicht, bei laufendem Messer Schnittgut zu entfernen oder zu schneidendes Material festzuhalten. Entfernen Sie**

eingeklemmtes Schnittgut nur bei ausgeschaltetem Gerät. Ein Moment der Unachtsamkeit bei Benutzung der Heckenschere kann zu schweren Verletzungen führen.

- **Tragen Sie die Heckenschere am Griff bei stillstehendem Messer. Bei Transport oder Aufbewahrung der Heckenschere stets die Schutzabdeckung aufziehen.** Sorgfältiger Umgang mit dem Gerät verhindert die Verletzungsgefahr durch das Messer.
- **Halten Sie das Elektrowerkzeug an den isolierten Griffflächen, da das Schneidmesser in Berührung mit versteckten Leitungen oder dem eigenen Netzkabel kommen kann.** Der Kontakt des Schneidmessers mit einer spannungsführenden Leitung kann metallene Geräteteile unter Spannung setzen und zu einem elektrischen Schlag führen.
- **Halten Sie das Kabel vom Schneidbereich fern.** Während des Arbeitsvorgangs kann das Kabel im Gebüsch verdeckt sein und versehentlich durchtrennt werden.

Contents

Guide to Using this Manual	23
Safety Precautions and Working Techniques	23
Using the Unit	28
Connecting to Power Supply	29
Switching On	30
Switching Off	31
Rotating Handle	31
Storing the Machine	32
Sharpening Instructions	32
Maintenance and Care	33
Minimize Wear and Avoid Damage	34
Main Parts	35
Specifications	36
Maintenance and Repairs	38
Disposal	38
EC Declaration of Conformity	38
General Power Tool Safety Warnings	39

Dear Customer,

Thank you for choosing a quality engineered STIHL product.

It has been built using modern production techniques and comprehensive quality assurance. Every effort has been made to ensure your satisfaction and trouble-free use of the product.

Please contact your dealer or our sales company if you have any queries concerning this product.

Your



Dr. Nikolas Stihl

STIHL®

This instruction manual is protected by copyright. All rights reserved, especially the rights to reproduce, translate and process with electronic systems.

Guide to Using this Manual

Pictograms

All the pictograms attached to the machine are shown and explained in this manual.

Symbols in text



WARNING

Warning where there is a risk of an accident or personal injury or serious damage to property.



NOTICE

Caution where there is a risk of damaging the machine or its individual components.

Engineering improvements

STIHL's philosophy is to continually improve all of its products. For this reason we may modify the design, engineering and appearance of our products periodically.

Therefore, some changes, modifications and improvements may not be covered in this manual.

Safety Precautions and Working Techniques



Some special safety precautions must be observed when working with this power tool because it has very sharp cutting blades and is powered by electricity.



It is important that you read the instruction manual before first use and keep it in a safe place for future reference. Non-observance of the instruction manual may result in serious or even fatal injury.

Observe all applicable local safety regulations, standards and ordinances.

If you have not used this type of power tool before: Have your dealer or other experienced user show you how to operate your machine or attend a special course in its operation.

Minors should never be allowed to use a power tool.

Keep bystanders, especially children, and animals away from the work area.

When the power tool is not in use, shut it off so that it does not endanger others. Secure it against unauthorized use.

The user is responsible for avoiding injury to third parties or damage to their property.

Do not lend or rent your power tool without the instruction manual. Be sure that anyone using it understands the information contained in this manual.

Persons who are not able to operate the power tool safely due to limited physical, sensory or mental ability may work with it only under supervision or after instruction by a responsible person.

The use of noise emitting power tools may be restricted to certain times by national or local regulations.

To operate the power tool you must be rested, in good physical condition and mental health.

If you have any condition that might be aggravated by strenuous work, check with your doctor before operating a power tool.

Do not operate the power tool if you are under the influence of any substance (drugs, alcohol) which might impair vision, dexterity or judgment.

Use your hedge trimmer only for cutting hedges, shrubs, scrub and similar materials.

It must not be used for any other purpose because of the increased risk of accidents and damage to the machine.

To reduce the risk of accidents, always disconnect the plug from the power supply before carrying out any work on the power tool.

Never jerk the power cord to disconnect it from the wall outlet. To unplug, grasp the plug, not the cord.

Unsuitable extension cords can be extremely dangerous.

Make sure that the conductor cross section (wire gauge) of extension cords meets the minimum requirements – see chapter on "Connecting to Power Supply".

When you use an extension cord, make sure the plug and coupling are waterproof or positioned in such a way that they cannot come into contact with water.

Only use cutting blades and accessories that are explicitly approved for this power tool by STIHL or are technically identical. If you have any questions in this respect, consult a servicing dealer. Use only high quality tools and accessories in order to avoid the risk of accidents and damage to the machine.

STIHL recommends the use of genuine STIHL tools and accessories. They are specifically designed to match the product and meet your performance requirements.

Never attempt to modify your power tool in any way since this may increase the risk of personal injury. STIHL excludes all liability for personal injury and damage to property caused while using unauthorized attachments.

Do not use a pressure washer to clean the unit. The solid jet of water may damage parts of the unit.

Do not spray the power tool with water.

Clothing and Equipment

Wear proper protective clothing and equipment.



Clothing must be sturdy but allow complete freedom of movement. Wear snug-fitting clothing, an overall and jacket combination, do not wear a work coat.

Avoid clothing that could get caught on branches or brush or moving parts of the machine. Do not wear a scarf, necktie or jewelry. Tie up and confine long hair (e.g. with a hair net, cap, hard hat, etc.).



Wear sturdy shoes with non-slip soles.

Safety Glasses, Hearing Protection



WARNING



To reduce the risk of eye injuries, wear snug-fitting safety glasses in accordance with European Standard EN 166. Make sure the safety glasses are a good fit.

Wear hearing protection, e.g. earplugs or ear muffs.



Wear heavy-duty work gloves made of durable material (e.g. leather).

STIHL offers a comprehensive range of personal protective clothing and equipment.

Transporting the Power Tool

Always switch off the power tool, unplug it from the power supply and fit the blade scabbard – even when you carry the unit for short distances.

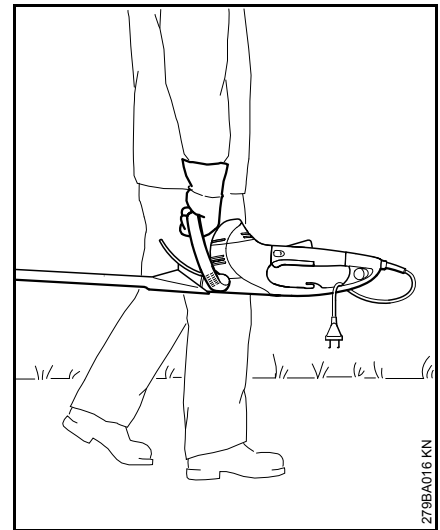

Carry the power tool by the handle – cutting blades behind you.

In vehicles: Properly secure the power tool to prevent turnover and damage.

Before Starting Work

Check that your power tool is properly assembled and in good condition – refer to appropriate chapters in the instruction manual.

- Voltage and frequency of the machine (see rating plate) and the voltage and frequency of your power supply must be the same.
- Check the connecting cord, plug and extension cord for damage. Never use damaged cords, couplings and plugs or connecting cords that do not comply with regulations.

- Receptacles of extension cords must be splash-proof.
- Position and mark the power supply cord so that it cannot be damaged or stepped on, tripped over or endanger others.
- Trigger switch lockout, trigger, switch lever and auxiliary switch must move freely and return to the idle position when they are released.
- Cutting blades securely mounted and in good condition (clean, move freely, not warped), properly sharpened and thoroughly sprayed with STIHL resin solvent (lubricant).
- Check cutter guard (if fitted) for damage.
- Never attempt to modify the controls or safety devices in any way.
- Keep the handles dry and clean – free from oil and dirt – for safe control of the power tool.

To reduce the risk of accidents, do not operate your power tool if it is damaged or not properly assembled.

To reduce the risk of electric shock:

- Always connect the power tool to a properly installed wall outlet.
- Make sure the extension cord used complies with the regulations for the intended application.
- Check that the insulation of the power cord, extension cord, plug and coupling is in good condition.

Holding and Controlling the Power Tool

Always hold the power tool firmly with both hands on the handles. Wrap fingers and thumbs firmly around the handles.

Right-handers

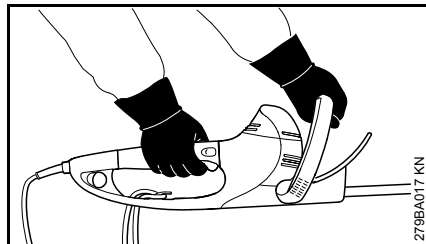

Right hand on the control handle and left hand on the loop handle.

Left-handers

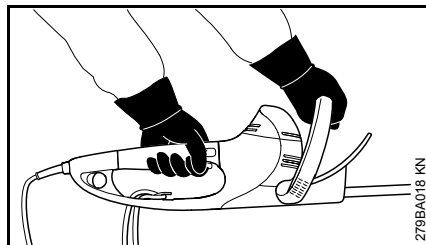

Left hand on the control handle and right hand on the loop handle.

Make sure you have firm and secure footing and hold the power tool so that the cutting blades are always away from your body.

During Operation

In case of imminent danger or in an emergency, switch off the motor immediately – release the trigger or switch lever or trigger or auxiliary switch.

Check that there are no bystanders in the general work area.

Watch the cutting blades at all times – do not cut areas of the hedge that you cannot see.

Be extremely careful when cutting tall hedges, check the other side of the hedge before starting work.



The drive motor is not waterproof. **To reduce the risk of a short circuit or electrocution**, never work with the power tool in the rain or in wet or very damp locations.

Do not leave the power tool outdoors in the rain.

Your power tool is equipped with a system designed to quickly stop the cutting blades – they come to an immediate standstill as soon as you release the trigger switch or the switch lever, or the auxiliary switch.

Check this function at regular short intervals. **To reduce the risk of injury**, do not operate your power tool if the cutting blades continue to run after switch-off. Contact your servicing dealer.

Take special care in slippery conditions (ice, wet ground, snow), on slopes or uneven ground.

Clear away fallen branches, scrub and cuttings.

Watch out for obstacles: Roots and tree stumps which **could cause you to trip or stumble**.

When working at heights:

- Always use a lift bucket
- Never work on a ladder or in a tree
- Never work on an insecure support

Be particularly alert and cautious when wearing hearing protection because your ability to hear warnings (shouts, alarms, etc.) is restricted.

To reduce the risk of accidents, take a break in good time to avoid tiredness or exhaustion.

Work calmly and carefully – in daylight conditions and only when visibility is good. Stay alert so as not to endanger others.

The gearbox becomes hot during operation. **To reduce the risk of burn injury**, do not touch the gearbox housing.

If your power tool is subjected to unusually high loads for which it was not designed (e.g. heavy impact or a fall), always check that it is in good condition before continuing work – see also "Before Starting Work". Make sure the safety devices are working properly. Do not continue operating your power tool if it is damaged. In case of doubt, consult your servicing dealer.

Inspect the hedge and work area to avoid damaging the cutting blades:

- Remove stones, rocks, pieces of metal and other solid objects.
- When working close to the ground, make sure that no sand, grit or stones get between the blades.
- Take particular care when cutting hedges next to or against wire fences.

To avoid the risk of electrocution, do not touch electric power lines – never cut through electric power lines.



Do not touch the cutting blades while the motor is running. If the cutting blades become jammed by thick branches or other obstructions, switch off immediately and disconnect the plug from the power supply before attempting to free the blades.

If the hedge is very dusty or dirty, spray the blades with STIHL resin solvent from time to time during cutting. This helps reduce blade friction as well as the aggressive effects of sap and the build-up of dirt particles.

The dust that occurs during operation may be harmful to health. If dust levels are very high, wear a suitable respirator.



If the power supply cord is damaged, immediately disconnect the plug from the wall outlet **to avoid the risk of electric shock**.

Never jerk the power cord to disconnect it from the wall outlet. To unplug, grasp the plug, not the cord.

Avoid damage to the power supply cord. Do not drive over it, pinch or tug it.

Position the connecting and extension cords correctly:

- Do not chafe on edges, pointed or sharp objects
- Do not squeeze through gaps in doors or windows
- If cords are twisted – unplug the power tool and straighten them out
- Never touch the cutting attachment
- Always unwind the extension cord completely from the cable drum to reduce the risk of fire from overheating.

Before leaving the power tool unattended: Switch off the power tool and unplug it from the power supply.

Check the cutting blades at regular short intervals during operation or immediately if there is a noticeable change in cutting behavior:

- Switch off the power tool, wait for the cutting blades to come to a standstill, disconnect plug from power supply.
- Check condition and tightness, look for cracks.
- Check sharpness.

Always switch off the power tool and unplug it from the power supply before replacing the cutting blades. This avoids the **risk of injury** from the motor starting unintentionally.

To reduce the risk of fire, always clean plant residue, chips, leaves and excess lubricant off the motor.

After Finishing Work

Always clean dust and dirt off the machine – do not use any grease solvents for this purpose.

Spray the blades with STIHL resin solvent. Run the motor briefly so that the solvent is evenly distributed.

Vibrations

Prolonged use of the power tool may result in vibration-induced circulation problems in the hands (whitefinger disease).

No general recommendation can be given for the length of usage because it depends on several factors.

The period of usage is prolonged by:

- Hand protection (wearing warm gloves)
- Work breaks

The period of usage is shortened by:

- Any personal tendency to suffer from poor circulation (symptoms: frequently cold fingers, tingling sensations).
- Low outside temperatures.
- The force with which the handles are held (a tight grip restricts circulation).

Continual and regular users should monitor closely the condition of their hands and fingers. If any of the above

symptoms appear (e.g. tingling sensation in fingers), seek medical advice.

Maintenance and Repairs

Always switch off the machine and disconnect the plug from the power supply before carrying out any maintenance work to **reduce the risk of injury** from the motor starting unintentionally.

Service the machine regularly. Do not attempt any maintenance or repair work not described in the instruction manual. Have all other work performed by a servicing dealer.

STIHL recommends that you have servicing and repair work carried out exclusively by an authorized STIHL servicing dealer. STIHL dealers are regularly given the opportunity to attend training courses and are supplied with the necessary technical information.

Only use high-quality replacement parts in order to avoid the risk of accidents and damage to the machine. If you have any questions in this respect, consult a servicing dealer.

STIHL recommends the use of genuine STIHL replacement parts. They are specifically designed to match your machine model and meet your performance requirements.

Never attempt to modify your power tool in any way since this will increase the risk of personal injury.

Regularly check that the insulation of the power cord and plug is in good condition and shows no sign of ageing (brittleness).

Electrical components, e.g. power cord, may only be repaired or replaced by a qualified electrician.

Clean plastic components with a cloth. Do not use aggressive detergents. They may damage the plastic.

Do not spray the machine with water.

Check tightness of mounting screws on safety devices and the cutting attachment and retighten if necessary.

Clean cooling air inlets in motor housing as necessary.

Store the machine in a safe and dry place.

Using the Unit

Cutting Season

Observe country-specific or municipal rules and regulations for cutting hedges.

Do not use your power tool during other people's rest periods.

Preparations

Use lopping shears or a chain saw to cut out thick branches first.

Cutting Sequence

Cut the sides of the hedge first, then the top.

If a radical cut is necessary, cut a little at a time in several stages.

Rotating handle

Your hedge trimmer is equipped with a rotating handle to enhance user comfort – see chapter on “Rotating Handle”.

Disposal

Do not throw cuttings into the garbage can – they can be composted.

Working Technique

Vertical cut

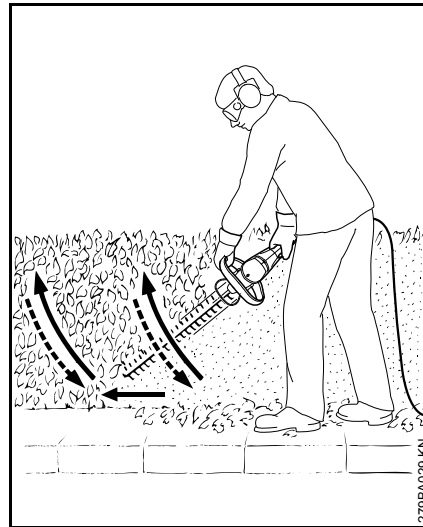

Swing the cutting blade from the bottom upwards in an arc – lower the nose of the blade, move along the hedge and then swing the blade up again in an arc.

Any working position above head height is tiring. To minimize the risk of accidents, work in such positions for short periods only.

Horizontal cut

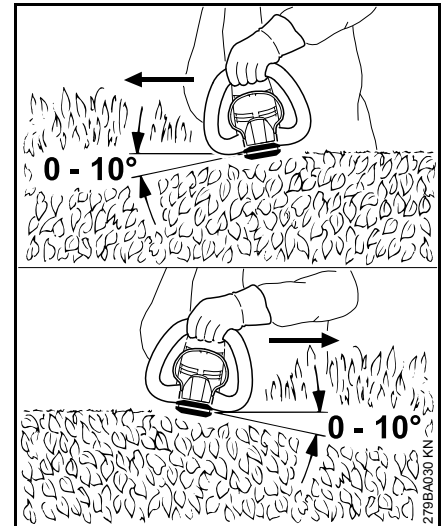

Hold the cutting blade at an angle of 0° to 10° as you swing the hedge trimmer horizontally, using both sides of the blade.

Swing the cutting blade in an arc towards the outside of the hedge so that the cuttings are swept to the ground.

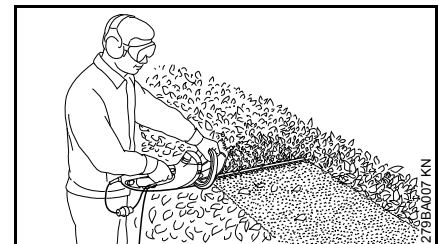

If the hedge is wide, cut it in several passes – one hand on the front switch lever – one hand on the control handle.

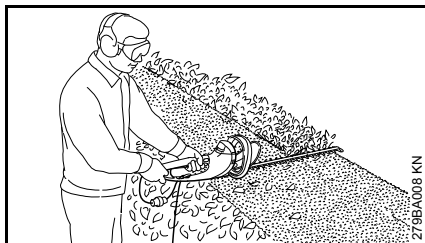

To extend your reach, hold the control handle with one hand and operate the auxiliary switch at the rear of the control handle with the other hand.

Connecting to Power Supply

The voltage and frequency of the machine (see rating plate) must match the voltage and frequency of the power connection.

The minimum fuse protection of the power connection must comply with the specifications – see "Specifications".

The machine must be connected to the power supply via an earth-leakage circuit breaker to disconnect the power supply if the differential current to earth exceeds 30 mA.

The power connection must correspond to IEC 60364 and relevant national regulations.

Extension cord

The design of the extension cord must at least fulfill the same features as the connecting cord on the machine. Observe the design marking (type designation) on the connecting cord.

The cores in the cord must have the following minimum cross-section depending on the mains voltage and cord length.

Cord length	Minimum cross-section
220 V – 240 V:	
Up to 20 m	1.5 mm ²
20 m to 50 m	2.5 mm ²
100 V – 127 V:	
Up to 10 m	AWG 14 / 2.0 mm ²
10 m to 30 m	AWG 12 / 3.5 mm ²

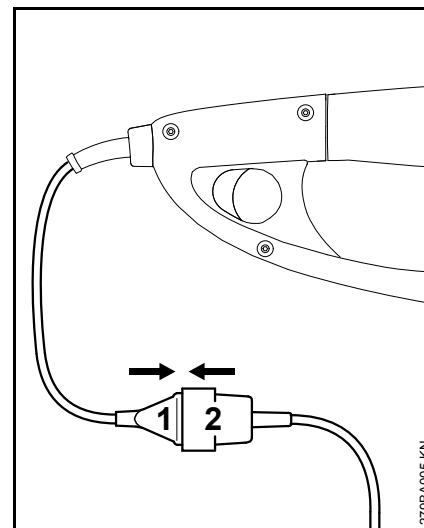

- Insert the plug (1) into the extension cord coupling (2).

Strain Relief

The strain relief (cord retainer) protects the connecting cord against damage.

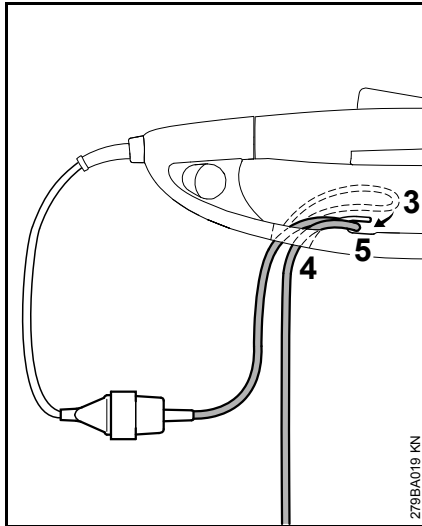

- Make a loop (3) in the extension cord.
- Pass the loop (3) through the opening (4).
- Slip the loop (3) over the hook (5) and pull it tight.
- Connect the extension cord plug to a properly installed wall outlet.

Switching On

- Make sure you have a secure and balanced footing.
- Stand upright – hold the power tool in a relaxed position.
- Make sure the cutting attachment is not touching the ground or any other objects.
- Hold the unit with both hands – one hand on the control handle – one hand on the loop handle.

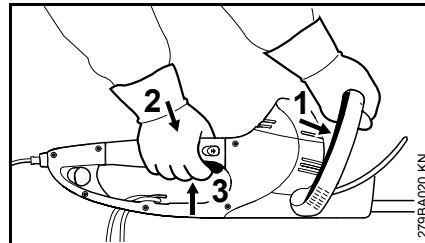

- Push the switch lever (1) against the loop handle and hold it there.
- Push down the trigger switch lockout (2), depress the trigger switch (3) and hold them in that position.

The machine is designed for two-hand operation, i.e. it will run only when the operator's hands are on the switch lever (1) and trigger switch (3).

To extend reach

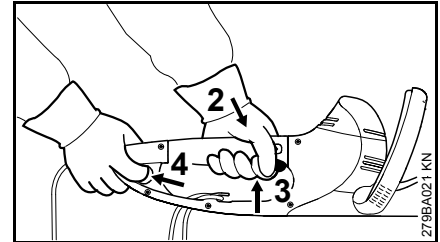

- Hold the power tool with both hands – one hand on the control handle – one hand on the auxiliary switch at the rear end of the control handle.
- Operate the auxiliary switch (4) and hold it in that position.
- Push down the trigger switch lockout (2), depress the trigger switch (3) and hold them in that position.

The machine is designed for two-hand operation, i.e. it will run only when the operator's hands are on the auxiliary switch (4) and trigger switch (3).

Switching Off

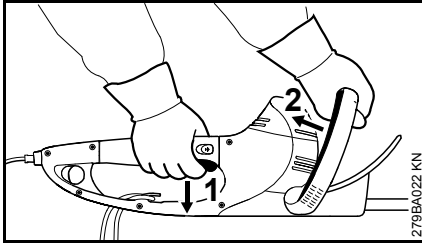

- Release the trigger switch (1) and the switch lever (2).

Extended reach position:

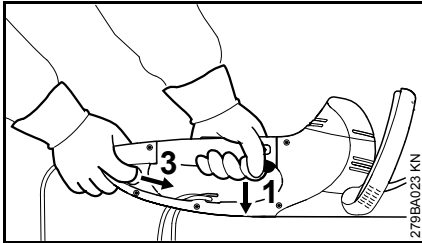

- Release the trigger switch (1) and auxiliary switch (3).

HSE 61, 71

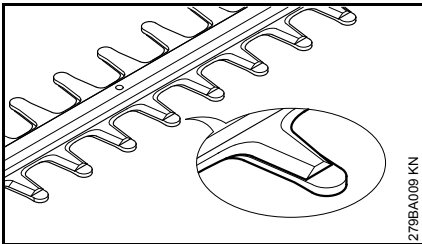

The blades are covered by the blade guard in the idle position.

HSE 81

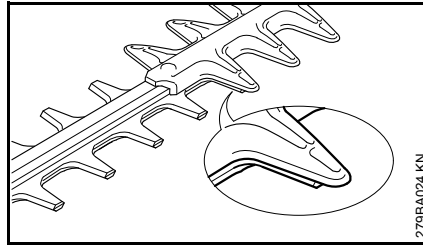

The blades are partly covered by the blade guard in the idle position.

Other hints

- During longer work breaks – disconnect the plug from the power supply.
- When the machine is not in use, shut it off so that it does not endanger others.
- Secure it against unauthorized use.

Rotating Handle

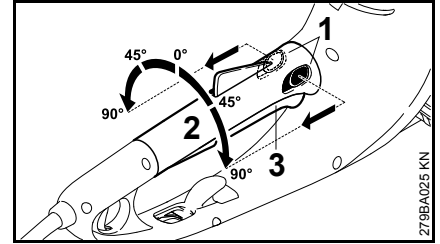

- Move the two buttons (1) in the direction of the arrows and hold them there.
- Rotate the handle (2) to the required position.
- Release the two buttons and engage the handle in position.

The handle (2) cannot be rotated while the trigger switch (3) is depressed.

Storing the Machine

For periods of 3 months or longer

- Clean the cutting blades, check condition and spray with STIHL resin solvent.
- Fit the blade scabbard.
- Thoroughly clean the machine, especially the cooling air inlets.
- Store the machine in a dry, locked location – the blade scabbard can be mounted to the wall for this purpose – out of the reach of children and other unauthorized persons.

Sharpening Instructions

When cutting performance and behavior begin to deteriorate, i.e. blades frequently snag on branches: Resharpener the cutting blades.

It is best to have the cutting blades resharpened by a dealer on a workshop sharpener. STIHL recommends a STIHL servicing dealer.

It is also possible to use a flat crosscut sharpening file. Hold the sharpening file at the prescribed angle (see "Specifications").

- Only sharpen the cutting edge – do not file blunt projecting parts of the cutting blade or the cutting blade guard (see "Main Parts and Controls")
- Always file towards the cutting edge.
- The file only sharpens on the forward stroke – lift it off the blade on the backstroke.
- Use a whetstone to remove burr from cutting edge.
- Remove as little material as possible.
- After sharpening, clean away filing or grinding dust and then spray the cutting blades with STIHL resin solvent.



Do not operate your machine with dull or damaged cutting blades. This may cause overload and will give unsatisfactory cutting results.

Maintenance and Care

The following intervals apply to normal operating conditions only. If your daily working time is longer or operating conditions are difficult (very dusty work area, etc.), shorten the specified intervals accordingly.		before starting work	after finishing work or daily	weekly	monthly	every 12 months	if problem	if damaged	if required
Complete machine	Visual Inspection	X							
	Clean		X						
Two-hand control	Check function – the cutting blades must quickly come to a standstill when the trigger switch or switch lever, or the trigger switch, or auxiliary switch is released	X							
Cooling inlets	Visual Inspection		X						
	Clean								X
Cutting blades	Visual Inspection	X							
	Clean ²⁾		X						
	Sharpen ¹⁾²⁾								X
	Have replaced by dealer ¹⁾							X	
Gearbox and connecting rod	Have checked by servicing dealer ¹⁾ after every 50 hours of operation								
	Have gearbox topped up with STIHL gear lubricant by servicing dealer ¹⁾								X
Carbon brushes	Have checked by servicing dealer ¹⁾ after every 100 hours of operation								
	Have replaced by dealer ¹⁾								X
All accessible screws and nuts	Retighten								X
Safety labels	Replace							X	
¹⁾ STIHL recommends a STIHL servicing dealer. ²⁾ Spray with STIHL resin solvent after cleaning									

Minimize Wear and Avoid Damage

Observing the instructions in this manual helps reduce the risk of unnecessary wear and damage to the power tool.

The power tool must be operated, maintained and stored with the due care and attention described in this instruction manual.

The user is responsible for all damage caused by non-observance of the safety precautions, operating and maintenance instructions in this manual. This includes in particular:

- Alterations or modifications to the product not approved by STIHL.
- Using tools or accessories which are neither approved or suitable for the product or are of a poor quality.
- Using the product for purposes for which it was not designed.
- Using the product for sports or competitive events.
- Consequential damage caused by continuing to use the product with defective components.

Maintenance Work

All the operations described in the "Maintenance Chart" must be performed on a regular basis. If these maintenance operations cannot be performed by the owner, they should be performed by a servicing dealer.

STIHL recommends that you have servicing and repair work carried out exclusively by an authorized STIHL

servicing dealer. STIHL dealers are regularly given the opportunity to attend training courses and are supplied with the necessary technical information.

If these maintenance operations are not carried out as specified, the user assumes responsibility for any damage that may occur. Among other things, this includes:

- Damage to the motor due to neglect or deficient maintenance (e.g. not cleaning cooling air inlets).
- Damage due to incorrect electrical connection (voltage, inadequately rated connecting cords).
- Corrosion and other consequential damage resulting from improper storage.
- Damage to the product resulting from the use of poor quality replacement parts.

Parts Subject to Wear and Tear

Some parts of the power tool are subject to normal wear and tear even during regular operation in accordance with instructions and, depending on the type and duration of use, have to be replaced in good time. Among other parts, this includes:

- Cutting blades

Main Parts

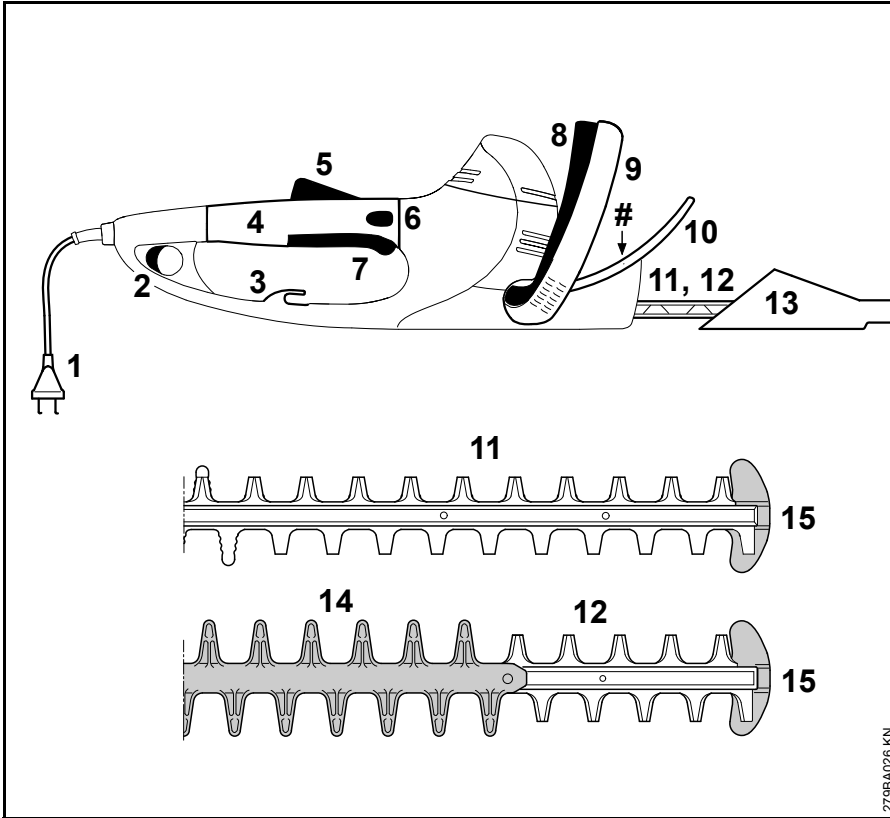

- 1 Power cord
- 2 Auxiliary switch
- 3 Strain relief (cord retainer)
- 4 Control handle with rotating grip
- 5 Trigger switch lockout
- 6 Handle lock
- 7 Trigger
- 8 Switch lever
- 9 Loop handle
- 10 Hand guard
- 11 Cutting blades (HSE 61, 71) – see "Specifications"
- 12 Cutting blades (HSE 81) – see "Specifications"
- 13 Blade scabbard
- 14 Blade guard (HSE 81 only)
- 15 Tip guard
- # Serial number

279BA026 KN

Specifications

Engine

HSE 61

Voltage:	230 - 240 V
Rated current:	2.1 A
Frequency:	50 Hz
Power consumption:	500 W
Fuse:	min. 10 A
Insulation:	II, 

HSE 71

Voltage:	230 - 240 V
Rated current:	2.6 A
Frequency:	50 Hz
Power consumption:	600 W
Fuse:	min. 10 A
Insulation:	II, 

HSE 81

Voltage:	230 - 240 V
Rated current:	2.8 A
Frequency:	50 Hz
Power consumption:	650 W
Fuse:	min. 10 A
Insulation:	II, 

Cutting Blades

HSE 61

Sharpening angle:	34°
Tooth spacing:	29 mm
Stroke rate:	3,200/min
Cutting length:	500 mm, 600 mm

HSE 71

Sharpening angle:	28°
Tooth spacing:	36 mm
Stroke rate:	2,600/min
Cutting length:	600 mm, 700 mm

HSE 81

Sharpening angle:	45°
Tooth spacing:	36 mm
Stroke rate:	2,600/min
Cutting length:	500 mm, 600 mm, 700 mm

Weight

HSE 61

500 mm blade:	3.9 kg
500 mm blade ¹⁾ :	4.6 kg
600 mm blade:	4.1 kg

HSE 71

600 mm blade:	4.1 kg
500 mm blade ¹⁾ :	4.8 kg
700 mm blade:	4.2 kg
700 mm blade ¹⁾ :	4.9 kg

HSE 81

500 mm blade:	4.1 kg
600 mm blade:	4.2 kg
700 mm blade:	4.4 kg
700 mm blade ¹⁾ :	5.0 kg

¹⁾ Version with 10 meter power supply cord for UK

Noise and Vibration Data

Noise and vibration data are determined on the basis of the rated maximum speed.

For further details on compliance with Vibration Directive 2002/44/EC see www.stihl.com/vib/

Sound pressure level L_p to EN 60745-2-15

HSE 61

500 mm blade:	85 dB(A)
600 mm blade:	85 dB(A)

HSE 71

600 mm blade:	88 dB(A)
700 mm blade:	88 dB(A)

HSE 81

500 mm blade:	88 dB(A)
600 mm blade:	88 dB(A)
700 mm blade:	88 dB(A)

Sound power level L_w to EN 60745-2-15

HSE 61

500 mm blade:	96 dB(A)
600 mm blade:	96 dB(A)

HSE 71

600 mm blade: 99 dB(A)

700 mm blade: 99 dB(A)

HSE 81

500 mm blade: 99 dB(A)

600 mm blade: 99 dB(A)

700 mm blade: 99 dB(A)

Vibration measurement a_{hv} to EN 60745-2-15**HSE 61**

500 mm blade:

Left handle: 5.3 m/s²Right handle: 3.3 m/s²**HSE 61**

600 mm blade:

Left handle: 5.3 m/s²Right handle: 3.3 m/s²**HSE 71**

600 mm blade:

Left handle: 3.8 m/s²Right handle: 2.6 m/s²**HSE 71**

700 mm blade:

Left handle: 3.8 m/s²Right handle: 2.6 m/s²**HSE 81**

500 mm blade:

Left handle: 3.2 m/s²Right handle: 2.1 m/s²**HSE 81**

600 mm blade:

Left handle: 3.5 m/s²Right handle: 2.5 m/s²**HSE 81**

700 mm blade:

Left handle: 3.5 m/s²Right handle: 2.5 m/s²

The K-factor in accordance with Directive 2006/42/EC is 2.0 dB(A) for the sound pressure level and sound power level; the K-factor in accordance with Directive 2006/42/EC is 2.0 m/s² for the vibration level.

The vibration values quoted above have been measured according to a standardized test procedure and may be used to compare electric power tools.

Depending on the type of usage, the vibrations that actually occur may differ from the values quoted.

The vibration values quoted may be used for an initial assessment of the user's exposure to vibrations.

The actual exposure to vibrations has to be evaluated. This process may also take into account times during which the electric power tool is switched off and times during which it is switched on but running without load.

Observe measures to reduce vibration exposure to protect the user – see section on "Vibrations" in chapter on "Safety Precautions and Working Techniques".

REACH

REACH is an EC regulation and stands for the Registration, Evaluation, Authorisation and Restriction of Chemical substances.

For information on compliance with the REACH regulation (EC) No. 1907/2006 see www.stihl.com/reach.

Maintenance and Repairs

Users of this machine may only carry out the maintenance and service work described in this user manual. All other repairs must be carried out by a servicing dealer.

STIHL recommends that you have servicing and repair work carried out exclusively by an authorized STIHL servicing dealer. STIHL dealers are regularly given the opportunity to attend training courses and are supplied with the necessary technical information.

When repairing the machine, only use replacement parts which have been approved by STIHL for this power tool or are technically identical. Only use high-quality replacement parts in order to avoid the risk of accidents and damage to the machine.

STIHL recommends the use of original STIHL replacement parts.

Original STIHL parts can be identified by the STIHL part number, the **STIHL** logo and the STIHL parts symbol  (the symbol may appear alone on small parts).

Disposal

Observe all country-specific waste disposal rules and regulations.

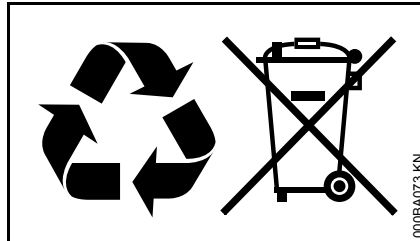

STIHL products must not be thrown in the garbage can. Take the product, accessories and packaging to an approved disposal site for environment-friendly recycling.

Contact your STIHL servicing dealer for the latest information on waste disposal.

EC Declaration of Conformity

ANDREAS STIHL AG & Co. KG
Badstr. 115
D-71336 Waiblingen

Germany

declare in exclusive responsibility that the product

Category:	Electric hedge trimmer
Make:	STIHL
Model:	HSE 61 HSE 71 HSE 81

Serial identification: 4812

conforms to the provisions of Directives 2011/65/EU, 2006/42/EC, 2014/30/EU and 2000/14/EC and has been developed and manufactured in compliance with the following standards in the versions valid at the time of production:

EN 55014-1, EN 55014-2, EN 60745-1, EN 60745-2-15, EN 61000-3-2, EN 61000-3-3

The measured and guaranteed sound power levels were determined according to Directive 2000/14/EC, Annex V, using the ISO 11094 standard.

Measured sound power level

HSE 61

500 mm blade:	96 dB(A)
600 mm blade:	96 dB(A)

HSE 71

600 mm blade:	99 dB(A)
700 mm blade:	99 dB(A)

HSE 81

500 mm blade: 99 dB(A)

600 mm blade: 99 dB(A)

700 mm blade: 99 dB(A)

Guaranteed sound power level**HSE 61**

500 mm blade: 98 dB(A)

600 mm blade: 98 dB(A)

HSE 71

600 mm blade: 101 dB(A)

700 mm blade: 101 dB(A)

HSE 81

500 mm blade: 101 dB(A)

600 mm blade: 101 dB(A)

700 mm blade: 101 dB(A)

Technical documents deposited at:

ANDREAS STIHL AG & Co. KG
Produktzulassung (Product Licensing)The year of manufacture, country of
manufacture and serial number are
applied to the product.

Done at Waiblingen, 01.03.2017

ANDREAS STIHL AG & Co. KG



General Power Tool Safety Warnings

This chapter reproduces the pre-formulated, general safety precautions specified in the EN 60745 European standard for hand-held motor-operated electric tools. **STIHL is required by law to print these standardized texts verbatim.**

The safety precautions and warnings on avoiding an electric shock given under "2) Electric Precautions" do not apply to STIHL cordless electric power tools



Read all safety warnings and instructions. Failure to follow the warnings and instructions may result in electric shock, fire and/or serious injury.

Save all warnings and instructions for future reference.

The term "power tool" in the warnings refers to your mains-operated (corded) power tool or battery-operated (cordless) power tool.

Thomas Elsner

Director Product Management and
Services