



power generators inverter

F 2001 iS



User manual

ORIGINAL MANUAL



# Dear Customer

Thank you for your trust in our equipment and for purchasing our high-quality FOGO® power generator. We are convinced that cooperation with world-leading manufacturers of components and application of innovative technological solutions, we have created a product that sets standards in terms of quality, safety and reliability. We hope that our product will meet your requirements in everyday use, ensuring long-lasting, trouble-free operation.

FOGO Sp. z o.o.



**Before the first start of the device, it is absolutely necessary to read the manual!!**

Safety of the user and all persons staying near to the device is very important. Therefore, before using the power generator, it is essential to read these instructions. The buyer of the power generator must ensure that this manual is always available for its operator and that every user reads the manual before starting any activities related to device operation.

Fogo power generators are designed and manufactured in accordance with current European directives, which we confirm by the declaration of conformity. In order to confirm that the power generators manufactured by our company meet the EU safety requirements, we apply an additional conformity assessment procedure carried out by an external Notified Body.

**FOGO® devices comply with the relevant European standards and other specific requirements in terms of the construction, operational safety and environmental protection. Each power generator is provided with CE declaration of conformity with the measuring sheet and technical specification of the unit.**



## Safety warnings

Please carefully read any messages preceded by the symbol  or the word INFORMATION.

### DANGER

- Failure to follow instructions **WILL CAUSE DEATH** or **SERIOUS INJURY**.

### WARNING

- Failure to follow these instructions **MAY RESULT IN DEATH** or **SERIOUS INJURY**.

### CAREFUL

- Failure to follow the instructions **MAY CAUSE INJURY**.

### NOTE

- Failure to follow the instructions may cause damage to the generator or devices connected to it.

## Description of the nameplate and identification of the generator set

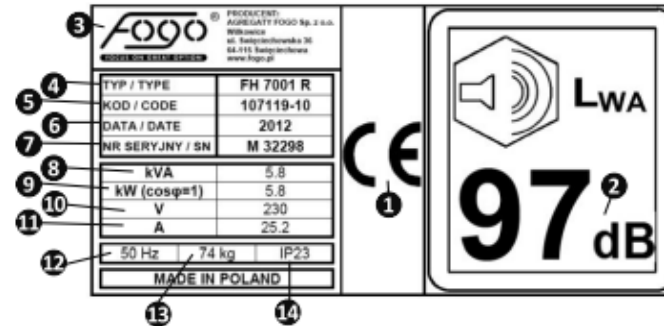

### NAMEPLATE

- CE mark confirming compliance with the requirements and European Directives,
- The level of noise emitted to the environment according to the Directive 2000/14/EC,
- Manufacturer's name and address,
- Model / Type,
- Manufacturer's code
- Year of production,
- Serial number of the device,
- Nominal power [kVA],
- Nominal power [kW],
- Voltage [V],
- Current [A],
- Frequency [Hz],
- Weight of power generator [kg],
- IP protection class

## Identification of the power generator set

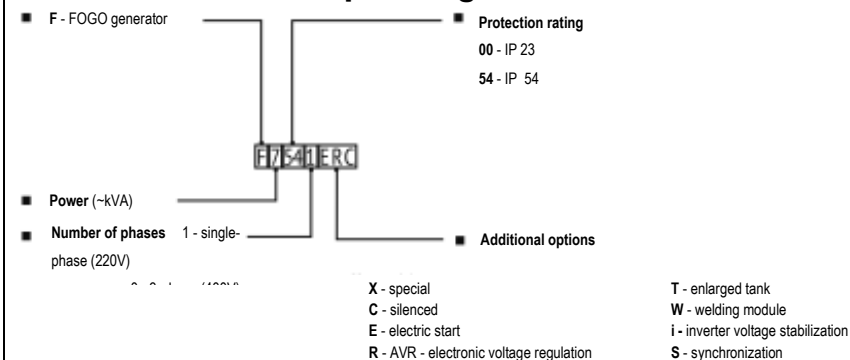

# Table of contents

<b>Safety warnings</b> .....	<b>4</b>	<b>6. Use</b> .....	<b>14</b>
<b>Description of the nameplate and identification of the generator set</b> .....	<b>4</b>	6.1 Starting the engine .....	15
<b>1. Safety information</b> .....	<b>6</b>	6.2 Stopping the engine .....	16
<b>2. Location of information plates</b>		6.3 Alternating current (AC) socket .....	16
<b>3. Description</b> .....	<b>9</b>	6.4 Battery charging .....	17
3.1 Control panel .....	9	6.5 Scope of application .....	18
<b>4. Control function</b> .....	<b>10</b>	<b>7. Technical servicing</b> .....	<b>19</b>
4.1 3-in-1 knob .....	10	7.1 Spark plug inspection .....	20
4.2 Low oil warning light .....	10	7.2 Carburettor adjustment .....	20
4.3 Overload indicator light (red) .....	11	7.3 Changing the engine oil .....	21
4.4 AC indicator light (green) .....	11	7.4 Air filter .....	21
4.5 DC breaker .....	11	7.5 Muffler strainer and spark arrester .....	22
4.6 AC breaker .....	12	7.6 Fuel tank filter .....	23
4.7 Engine Smart Control (ESC) .....	12	7.7 Fuel filter .....	23
4.8 Fuel tank cap .....	12	<b>8. Storage</b> .....	<b>23</b>
4.9 Fuel tank cap with bleed knob .....	12	8.1 Draining the fuel .....	23
4.10 Earth electrode .....	12	8.2 Engine .....	24
<b>5. Preparation</b> .....	<b>13</b>	<b>9. Troubleshooting and fault elimination</b> .....	<b>25</b>
5.1 Fuel .....	13	9.1 Engine cannot be started .....	25
5.2 Engine oil .....	13	9.2 Generator does not produce electricity .....	25
<b>5.3 Checking before use</b> .....	<b>14</b>	<b>10. Specifications</b> .....	<b>26</b>
		<b>11. Cable connection diagram</b> .....	<b>27</b>

# 1. Safety information

Read and understand this manual before using the generator. Knowing safe operating procedures of your generator will help you avoid accidents.



Never use inside buildings



Never use in wet conditions

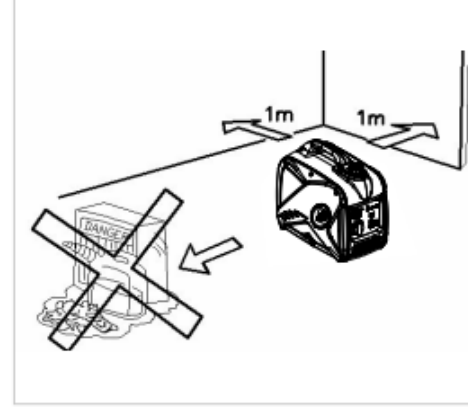

Keep at least 1 m away from flammable materials and other obstacles



Never smoke while refueling



Never connect the device to the home electrical system by yourself

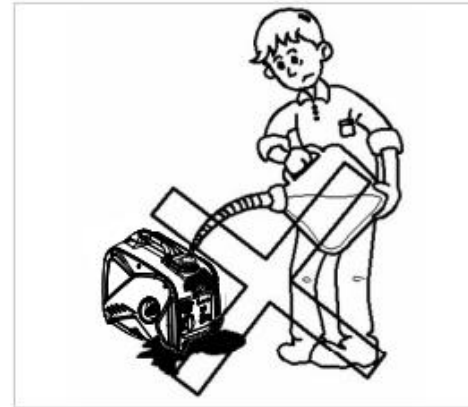

Do not spill fuel while refueling



Stop the engine before refueling

## Connections to the home electrical installation

If the generator is to be connected to the domestic electrical system as a backup power source, the connection should be made by a qualified electrician or other person with appropriate knowledge of electrical installations.

After connecting the receivers to the generator, check carefully whether the electrical connections are safe and reliable. Incorrect connection may damage the generator, cause fire or electric shock.

### NOTE

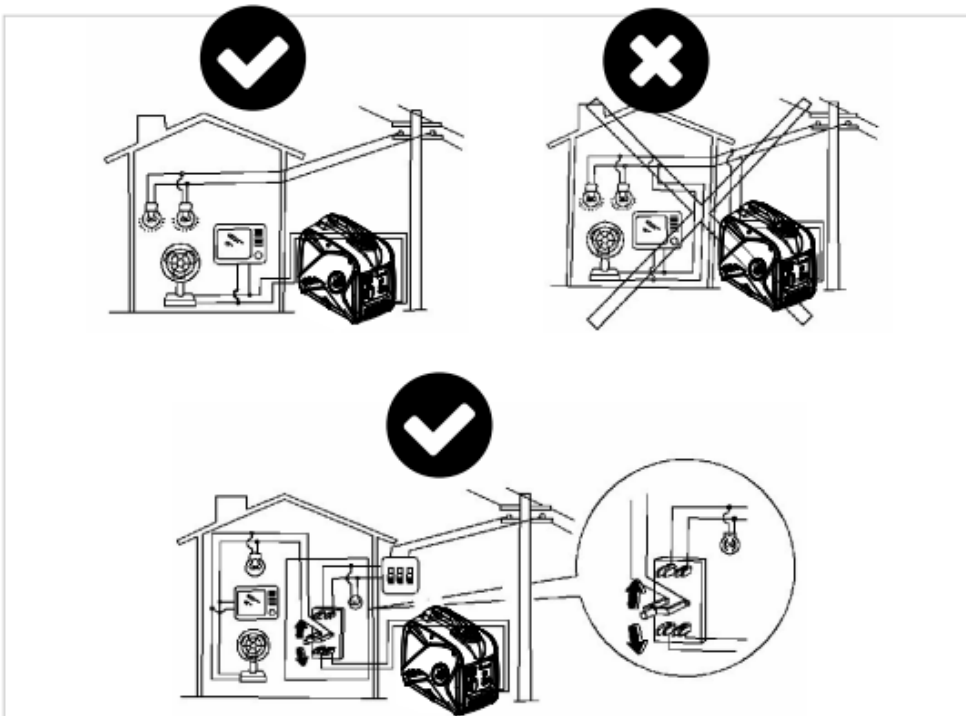

## Connections to the home electrical installation

In order to ensure protection against electric shock caused by poor condition of the devices, the generator must be earthed.



Earth electrode

### NOTE

Make sure the control panel, ventilation grille, and heat sink at the bottom of the inverter are free of dirt, mud and water, as blocking the cooling may damage the engine, inverter, or generator.

Do not place the generator together with other moving objects during transport, storage or use.

Any leakage from the generator can damage the generator or property.

## 2. Location of information plates

Before using the generator, read the following labels carefully.

**TIP:** Labels with instructions should be kept legible and replaced if necessary.

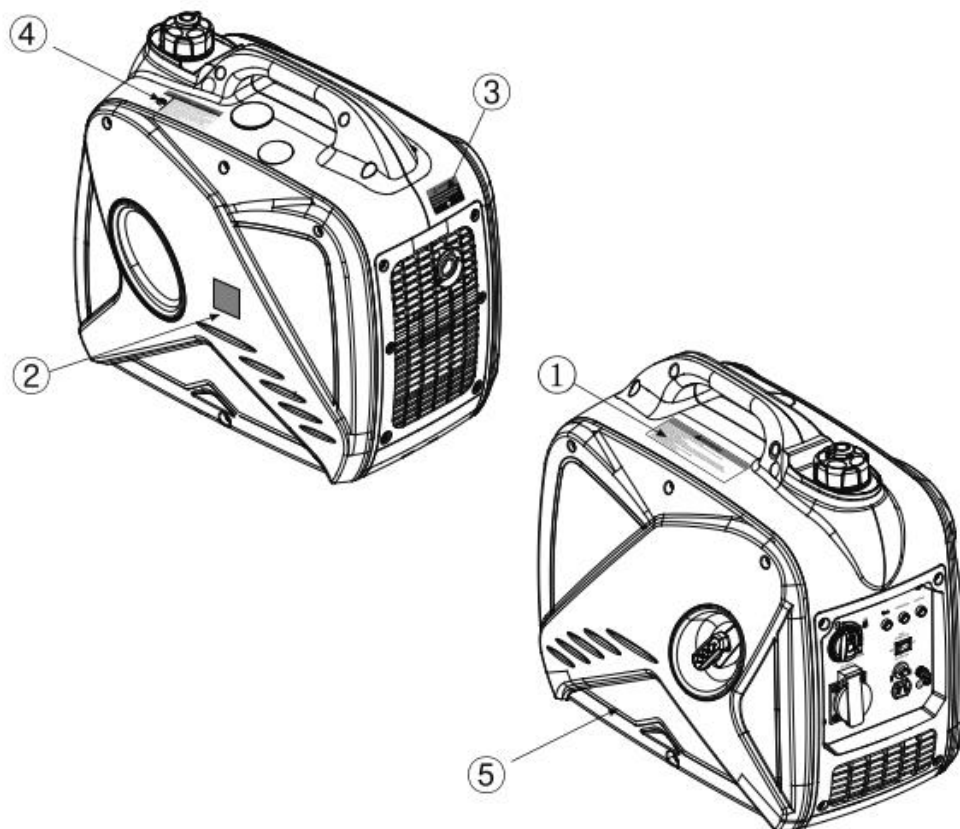

①

**⚠ UWAGA!!!**

- Podłączenia agregatu do instalacji elektrycznej w budynku może wykonać osoba posiadająca odpowiednie uprawnienia elektryczne po dokładnym zapoznaniu się z instrukcją obsługi.
- Nie napełniać zbiornika paliwa w czasie pracy urządzenia. Zachować szczególną ostrożność benzyna jest substancją wysoce łatwopalną a jej opary wybuchowe. Nie przepelniać zbiornika paliwa.
- Nie użytkować agregatu prądotwórczego w pobliżu materiałów łatwopalnych lub w miejscach zagrożonych wybuchem.
- Agregat posadzić na poziomej stabilnej powierzchni tak aby zagwarantować optymalny przepływ oleju i paliwa w silniku.
- Podczas pracy w trudnych warunkach pogodowych, należy zabezpieczyć agregat przed opadami deszczu oraz śniegu. Wilgoć lub lód mogą doprowadzić do uszkodzenia urządzenia lub zwarcia w instalacji elektrycznej.
- Podczas pracy agregatu:
  - nie ustawiać dodatkowych osłon dookoła agregatu.
  - nie umieszczać agregatu w dodatkowych skrzyniach,
  - nie umieszczać żadnych przedmiotów na pracującym agregacie i nie przykrywać go.
- Po zakończeniu pracy zakręcić zawór paliwa oraz zawór odpowietrzający umieszczony w korku paliwa. Przed zmagazynowaniem wychłodzić agregat.

②



③

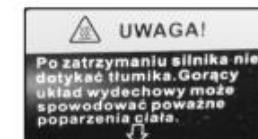

④

**⚠ OSTRZEŻENIE**

Niebezpieczeństwo - toksyczne spaliny. Pracujące silniki mogą wytwarzać tlenek węgla, który jest bezwonnym trującym gazem powodującym nudności, omdlenia lub śmierć. Urządzenia nie wolno uruchamiać ani użytkować wewnątrz budynków ani w zamkniętych przestrzeniach nawet przy otwartych oknach i drzwiach

⑤

**POWER BY 1000**

**⚠ UWAGA!** Przed pierwszym uruchomieniem należy dokładnie zapoznać się z instrukcją obsługi urządzenia.

Nie uruchamiać agregatu pracującego w zamkniętych przestrzeniach bez odpowiedniej wentylacji wentylacji.

Ważne! Nie dotykać palców podczas pracy silnika. Niebezpieczne powstawie poparzeń!

Agregat przeznaczone wyłącznie do użytku zewnętrznego.



### 3. Description

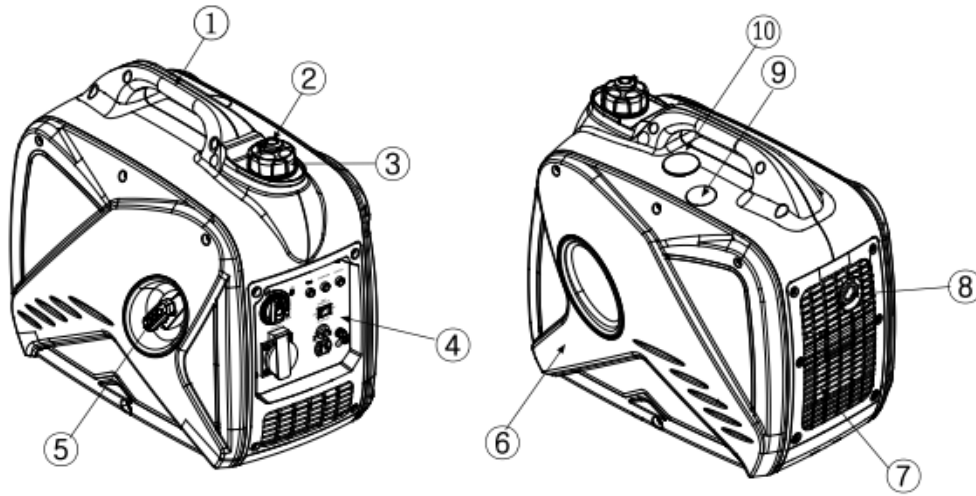

1. Carrying handle
2. Fuel tank cap with bleed knob
3. Fuel tank cap
4. Control panel
5. Recoil starter
6. Oil filler cap (remove cover)
7. Vent grate
8. Silencer
9. Spark plug service cover
10. Fuel gauge

### 3.1 Control panel

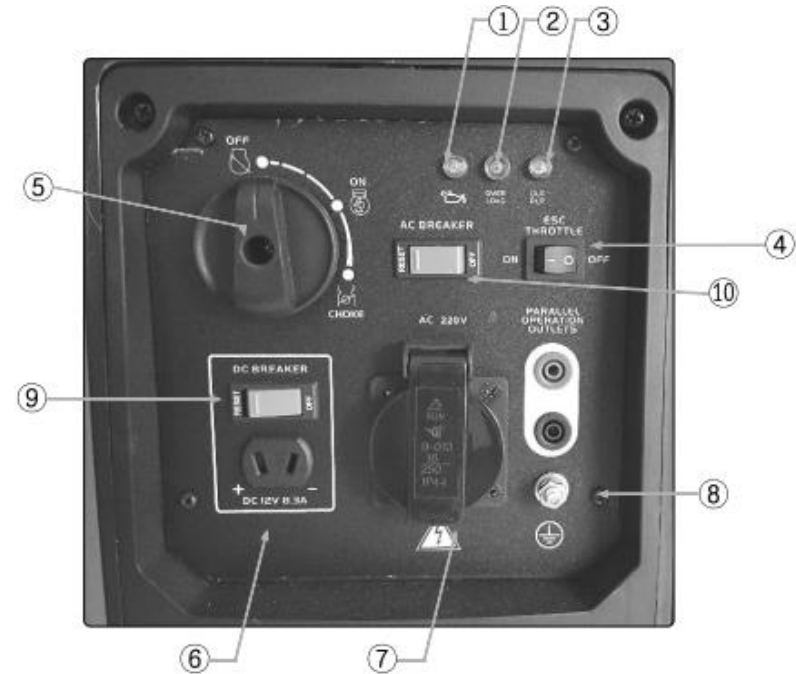

1. Low oil level warning light
2. Overload indicator light
3. AC pilot light - green (correct operation)
4. ESC (Engine Smart Control)
5. 3-in-1 switch knob  
(including on/off switch, fuel valve and choke)
6. DC socket
7. AC socket
8. Earth electrode
9. DC breaker
10. AC breaker

## 4. Control function

### 4.1 3-in-1 knob

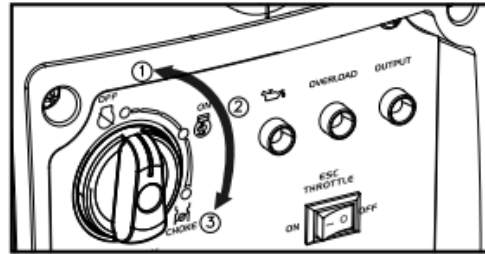

### 4.2 Low oil level warning light

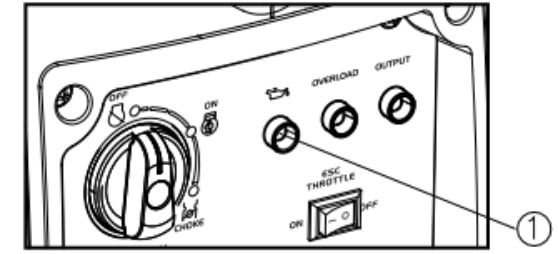

- [1] Engine switch / fuel valve in "OFF" position (deactivated);  
The ignition circuit is turned off. The fuel is open.  
Engine cannot be started
- [2] Engine switch / fuel valve / valve in "ON" position (activated);  
The ignition circuit is ON. Fuel is connected. The choke is turned on.  
The engine can be started.
- [3] Engine switch / fuel valve / suction in "CHOKE" position;  
The ignition circuit is ON. The fuel is open. The choke is turned off.  
The engine can be started.

When the oil level is below the lower limit, the low oil warning light (1) will illuminate and the engine will stop automatically. The engine cannot be started until the oil level is topped up.

#### TIP

If the engine stops or it cannot be started, turn the engine switch to the "ON" position, then pull the starter handle.  
If the low oil indicator light starts flashing for a few seconds, the oil level is too low. Add oil and restart the engine.

#### TIP

Choke is used only when starting a cold engine.

### 4.3 Overload indicator light (red)

The overload indicator light illuminates when an overload is detected. Overload occurs when connecting a receiver with a power greater than the power of the generator.

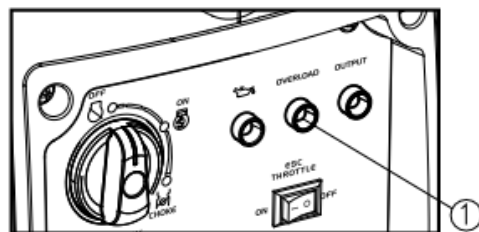

This can lead to the inverter overheating or increased AC voltage at the output. In such a situation, the AC breaker trips, which stops production of electricity in order to protect the generator and the devices connected to it. The AC pilot light (green) turns off and the overload indicator light (red) remains on, the engine will not shut down.

After the overload indicator light comes on and power is removed from the outlets, do the following:

1. Turn off all connected electrical devices and stop the engine.
2. Reduce the total power of the connected devices to the value consistent with the rated power.
3. Check that the cooling air intake and external parts of the control panel are not obstructed.

Remove any components causing restricted air flow

4. After checking, start the engine. Then the voltage will automatically return to the socket.

#### TIP

The overload indicator light may turn on for a few seconds when using electrical appliances that require high inrush currents, such as compressors or submersible pumps. However, this is not a malfunction.

### 4.4 AC indicator light (green)

The AC indicator light lights-up on when the engine has started and the generator is generating electricity.

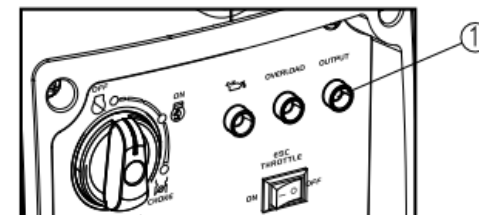

### 4.5 DC breaker

The DC breaker will automatically switch to the OFF position when the power of the DC electric receivers or batteries connected to the socket exceeds the allowable value. To use the device again, turn on the circuit breaker by switching the button to the "Reset" on position.

"RESET"

DC current is generated.

[1] "OFF"

DC current is not generated.

[2]

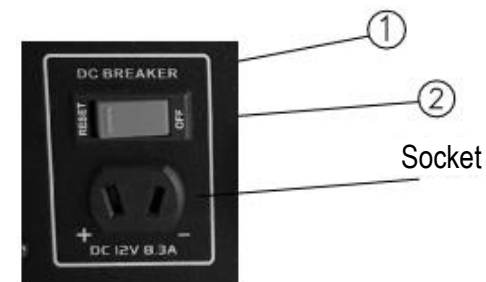

#### WARNING

In case of DC breaker tripping, the load of the connected battery should be reduced below the specified rated power of the generator. If the DC breaker trips again, stop using the device immediately and contact our authorized distributor. The protection may trip in case of a short circuit in the battery.

## 4.6 AC breaker

The AC breaker trips to the position "OFF" automatically when the electrical equipment connected to the generator starts to operate and the amperage is greater than the nominal value. In order to use the device again, turn on the breaker by pressing its button and moving it to the "RESET" position.

- [1] "RESET"  
Alternating current is generated
- [2] "OFF"  
Alternating current is not generated
- [3] Socket

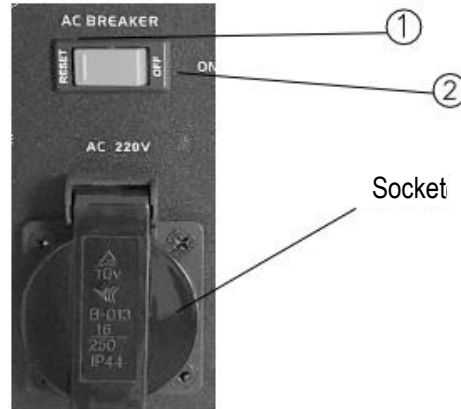

## 4.7 Engine Smart Control (ESC)

- [1] "ON"  
When the ESC switch is set to the "ON" position, the economy control unit sets the motor speed according to the needs of the connected load. This enables lower fuel consumption and quiet operation of the generator.
- [2] "OFF"  
When the ESC switch is set to the "OFF" position, the engine runs at rated speed (4500 rpm) regardless of whether a receiver is connected to the generator.

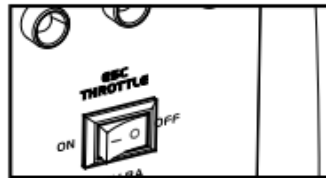

## TIP

Set the ESC switch to the "OFF" position when using electrical devices that require a high starting current, e.g. compressors or submersible pumps.

## 4.8 Fuel tank cap

Remove the fuel tank cap by turning it counter-clockwise.

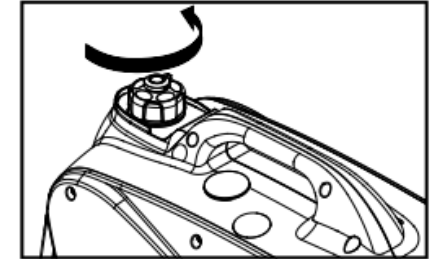

## Fuel tank cap with bleed knob

The fuel tank cap has an air vent knob to stop the flow of fuel.

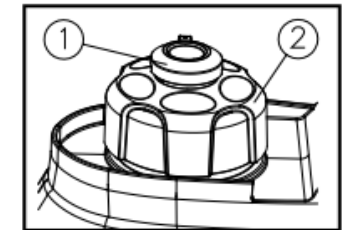

Turn the vent knob to the "ON" position. This allows the fuel to flow to the carburettor and the engine to run. When the engine is **not running**, turn the vent knob to the "OFF" position in order to stop the fuel flow.

## 4.10 Earthing

An earth electrode is used to ground the equipment to prevent electric shock. When the powered electrical equipment is grounded, the generator must also be grounded at all times.

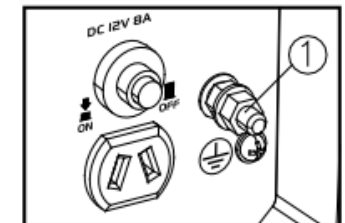

## 5. Preparation

### 5.1 Fuel

- Fuel is highly flammable and poisonous. Before filling fuel read carefully "SAFETY INFORMATION."
- Do not pour too much fuel into the fuel tank as fuel may spill due to its expansion when heated.
- Make sure the fuel tank cap is properly installed after refuelling.



#### NOTE

- Spilled fuel must be wiped up immediately with a clean, dry, soft cloth as it may damage painted surfaces and plastic parts.
- Use only unleaded gasoline. The use of leaded gasoline will severely damage the internal engine parts.
- Remove the fuel tank cap and fill the fuel tank to the level marked with the red line

[1] The red line

[2] Fuel level

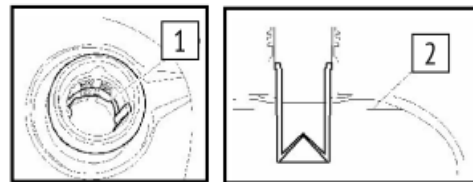

Recommended fuel: Unleaded gasoline  
Fuel tank capacity: total: 4.0 liters

Do not leave fuel in the generator's tank for an extended period of time.

### 5.2 Engine oil

The generator is shipped to the customer without engine oil. Do not start the engine until the correct engine oil has been added.

- [1] Place the generator on a flat surface.
- [2] Loosen the screws, and then remove the cover.
- [3] Remove the oil filler cap.

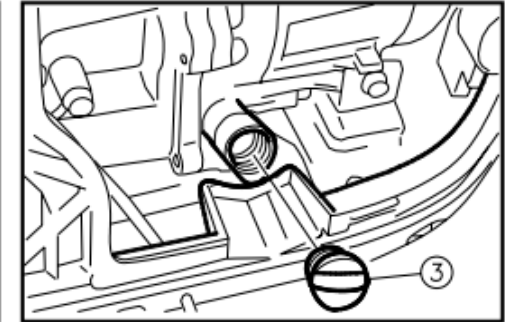
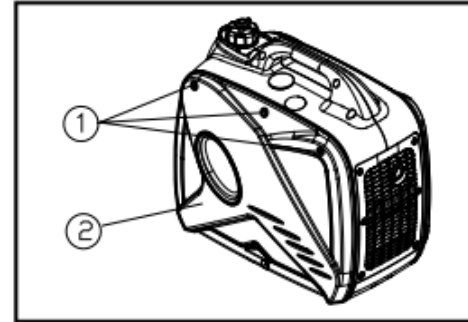

- [4] Pour in the specified amount of the recommended engine oil and then tighten the oil filler cap.

- [5] Install the cover and tighten the screws.

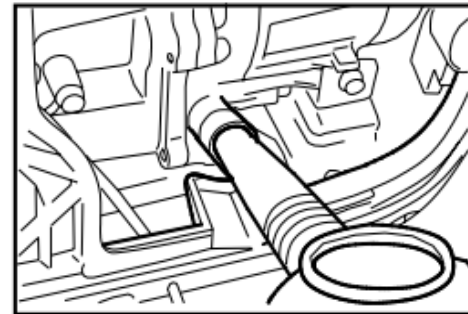

Recommended engine oil: SAE SJ 15W-40

Recommended engine oil grade: API Service type SE or higher

The amount of engine oil: 0.35 l

## 5.3 Checking before use

### WARNING

Before use, the generator should be carefully inspected. If any faults are found, they must be removed.

The owner is responsible for the condition of the generator. Important generator components can deteriorate quickly and unexpectedly, even when the generator is not in use.

### TIP

**Checks before use should be performed each time the generator is used.**

#### Checking before use

##### Fuel (see page 16)

- Check the fuel level in the tank.
- Add fuel if necessary.

##### Engine oil (see page 17)

- Check the engine oil level.
- If necessary, add the recommended oil to the specified level.
- Check the generator for oil and fuel leaks.

#### The point where a malfunction has been found during use

- Check the operation.
- If necessary, add the recommended oil to the specified level.
- If necessary, contact an authorized distributor of FOGO Sp. z o.o.

## 6. Operation

### WARNING

- Do not use the generator in a confined space as it may cause unconsciousness and death after a short time. The generator should be used in a place with good ventilation.
- Do not connect any electrical devices before starting the engine.

### NOTE

- The generator is shipped to the customer without engine oil. The engine should not be started until it has been filled with appropriate engine oil.
- When adding engine oil, do not tilt the generator. This can cause overfilling with oil and damage the engine.

### TIP

The generator can be used with rated power in standard weather conditions.

"Standard weather conditions"

Ambient temperature 25°C

Atmospheric pressure 1000 hPa

Relative humidity 30%

Generator power varies with changes in temperature, altitude (lower air pressure at higher altitudes) and humidity.

The power of the generator decreases when the temperature, humidity and altitude are higher than the values determined for standard atmospheric conditions.

Additionally, when the generator is used in confined spaces, it is necessary to reduce the load due to the limited cooling capacity.

## 6.1 Starting the engine

1. Set the ESC switch to the "OFF" position. [1]

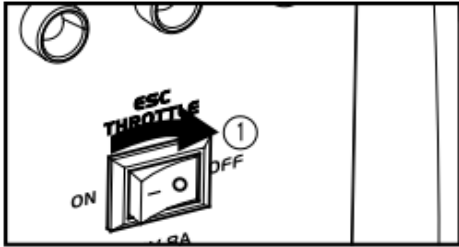

2. Turn the air vent knob to the "ON" position. [2]
3. Set the 3-in-1 switch to the CHOKE position. [3]

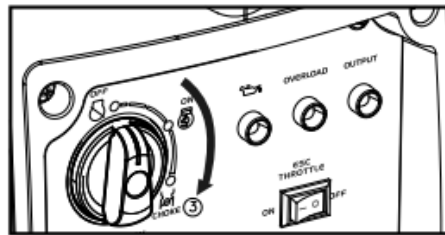
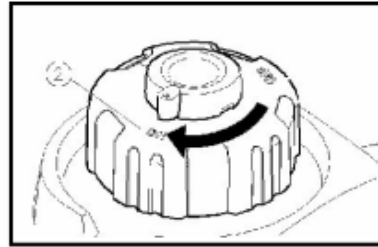

**TIP: The choke function is not required to start a warm engine.**

**If engine is warm, turn choke knob to the "ON" position.**

4. Pull the starter handle slowly until you feel resistance, then pull with great force and quickly.

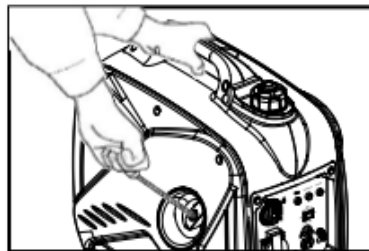

**TIP: Firmly grasp the carrying handle to prevent the generator from tipping over while pulling the starter handle.**

5. After starting the engine, warm it up until the engine does not stop when the choke knob returns to its original position [4].

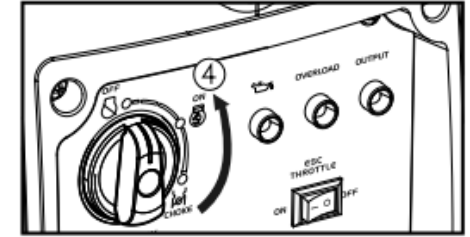

**TIP: During engine startup, when the ESC switch is in the "ON" position and the generator is not loaded:**

- At ambient temperatures below 0°C, the engine should be run at rated speed (4500 rpm) for 5 minutes to warm up.
- At ambient temperatures below 5°C, the engine should be run at rated speed (4500 rpm) for 3 minutes to warm up.
- The ESC unit operates normally after this time has elapsed while the ESC switch is in the "ON" position.

## 6.2 Stopping the Engine

### TIP:

Turn off all electrical devices.

1. Set the ESC switch to the "OFF" position. [1]
2. Disconnect all electrical devices.
3. Set the 3-in-1 switch to the position [2]
4. Turn the fuel tank cap vent knob to the "OFF" [3] position after the engine has cooled down completely.

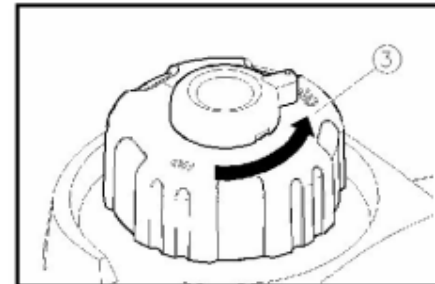
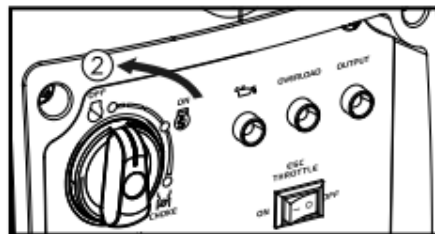
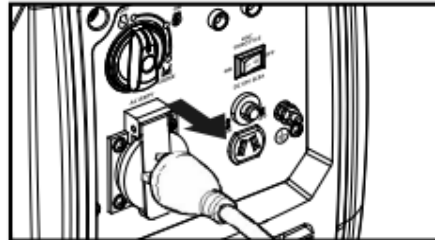
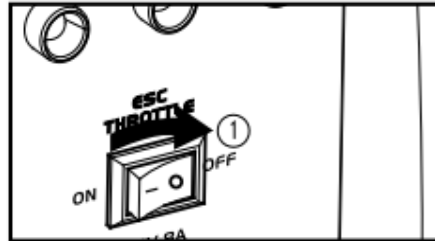

## 6.3 Alternating current (AC) socket

### WARNING

Make sure all electrical devices are turned off before connecting them to the generator.

### NOTE

- Make sure all electrical appliances, including cables and sockets, are in good condition before connecting them to the generator.
- Make sure the total load is compatible with the rated power of the generator.
- Make sure that the load current of the plug socket complies with the rated current of the socket.

### TIP:

Make sure the generator is grounded. When the powered electrical equipment is grounded, the generator must also be grounded at all times.

1. Start the engine.
2. Set the ESC switch to the "ON" position.
3. Connect the generator to an AC socket.
4. Check that the AC pilot light is on.
5. Turn off electrical appliances.

### TIP:

Set the ESC switch to the "OFF" position to increase the engine speed to the rated value. If the generator is connected to several receivers, remember to connect the receivers with the highest inrush current first, and then the receivers with the lowest inrush current.



## 6.4 Charging the battery

### TIP:

- The generator's DC rated voltage is 12V.
- First start the engine and then connect the generator to the battery being charged.
- Before charging the battery, make sure that the DC breaker is on.
  1. Start the engine.
  2. Connect the red lead from the charger to the positive (+) battery terminal.
  3. Connect the black lead from the charger to the negative (-) battery terminal.
  4. Set the ESC switch to the "OFF" position in order to start charging the battery.

### NOTE

- Make sure that the ESC switch is in the "OFF" position when charging the battery.
- Make sure the charger red lead is connected to the positive (+) terminal and the black wire to the negative (-) terminal of the battery.  
**Reverse connection is prohibited.**
- Connect the charger leads to the battery terminals in a stable manner to prevent their disconnection due to engine vibration or other disturbances.
- Charge the battery in accordance with the correct procedure, following the instructions in the battery manual.
- The DC breaker trips automatically when during the battery charging current exceeds the rated value. To resume battery charging, switch on the DC breaker by pressing its button and turning it to the "ON" position.

If the DC breaker trips again, stop charging the battery immediately and contact the authorized distributor of FOGO Sp. z o.o.

### TIP:

- To determine when to stop charging the battery, follow the instructions in the battery user manual.
- Measure the specific gravity of the electrolyte to determine if the battery is fully charged. When fully charged, the electrolyte density should be between 1.26 and 1.28.
- It is recommended to check the electrolyte density at least once an hour to avoid overcharging the battery.

### NOTE

While charging the battery, do not go near with an open flame, and do not turn on and off electrical appliances near the battery. The resulting sparks can ignite the gas (hydrogen) which is leaking from the battery.

The electrolyte is poisonous and dangerous, and the hydrochloric acid it contains can cause severe burns. Avoid contact with skin, eyes and clothing. Countermeasure:

EXTERNAL: Rinse with water.

INTERNAL: Drink plenty of water or milk. Then drink the magnesium milk, beaten egg or vegetable oil. Call a physician immediately.





EYES: Rinse with water for 15 minutes and obtain medical attention immediately.

Batteries generate explosive gases. Do not use sparks, naked flames, smoking, etc. near them. Provide good ventilation when charging or using in confined spaces. Always protect your eyes when working near batteries.

**KEEP AWAY FROM CHILDREN.**

## 6.5 Scope of application

When using the generator, make sure the total load is compatible with the rated power of the generator. Otherwise, there is a risk of damage to the generator.

AC				DC 
Power factor	1	0.8-0.95	0.4-0.75 (efficiency 0.85)	
Rated power	≤1800 W	≤1440 W	≤720 W	Rated voltage 12 V

### TIP:

- The applicable power applies when the device is used alone.
- Simultaneous generation of AC and DC current is possible, but the total power of the powered devices must not exceed the rated power of the generator.

0

Generator rated power		1800 Watts
Frequency	Power factor	
AC	1.0	≤1800 W
	0.8	≤1440 W
DC	---	96 W (12 V/8.3 A)

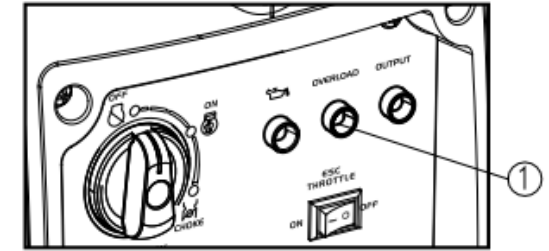

### NOTE

- Overload must not be allowed. The total power of all powered electrical devices must not exceed the power of the generator. Overloading damages the generator.
- When powering precision devices, electronic controllers, PCs, electronic computers, microprocessor devices or battery chargers, the generator should be placed at a sufficient distance from them to prevent electrical interference caused by a running engine. Also, make sure that the electromagnetic disturbance produced by the motor does not interfere with other electrical devices in the vicinity of the generator.
- If the generator is to be used for powering medical devices, consult the manufacturer, medical personnel, or hospital first.

Some general purpose electric appliances or engines have high inrush currents which prevent them from being powered by the generator, even when the power supply is within the range given in the table above. Contact the device manufacturer for additional information.

## 7. Technical servicing

The engine must be properly serviced to ensure its safe, economical, trouble-free and environmentally friendly operation.

Regular servicing is essential to keep the internal combustion engine in good working order. The following maintenance schedule and periodic inspection procedures must be strictly adhered to:

### NOTE

- If the internal combustion engine is run frequently under high temperature or heavy load conditions, the oil should be changed every 25 hours.
- If the engine is run frequently in dusty conditions or in difficult environmental conditions, clean the air filter every 10 hours, and if necessary, replace it every 25 hours.
- Servicing should be performed after the specified time or number of hours, whichever comes first.
- If the maintenance is not performed on time, it should be performed as soon as possible.

Items	Frequency	Frequency			
		Each time	After the 1st month or the first 20 operating hours	Then every 3 months or 50 operating hours	Every year or 100 operating hours
Engine oil	Check refill	✓			
	Replacement		✓	✓	
Air filter element	Check	✓			
	Cleaning		✓		
	Replacement			✓	
Decanter (if present)	Cleaning				✓
Spark plug	Check adjustment				✓
	Replacement	Every year or 250 operating hours			
Spark arrestor	Cleaning			✓	
Idle gear (if present)*	Check adjustment				✓
Valve clearance*	Check adjustment				✓
Fuel tank and fuel filter*	Cleaning				✓
Fuel line	Check	Every 2 years (replace if necessary)			
Cylinder head, piston	Removal of carbon deposit*	<225 cc, every 125 h			
		≥225 cc, every 250 h			
* These elements should be serviced and repaired by our authorized distributor, unless the owner has the appropriate tools and knowledge in the field of mechanical service.					

### WARNING

**Before starting operation, switch off the engine. Place the engine on a level surface and remove the spark plug cap to prevent the engine from starting.**

**The engine must not be used in a poorly ventilated room or any other confined space. Make sure the workplace is well ventilated. Engine exhaust can contain poisonous carbon monoxide, inhalation of which can cause shock, unconsciousness or even death.**

## 7.1 Spark plug inspection

Spark plugs are an important part of the engine and require periodic inspection.

1. Remove the cap and using the tool, remove the cap of the spark plug, insert the tool into the hole from the outside of the cap.
2. Insert the handle into the tool and turn it counter-clockwise to remove the spark plug.
3. Check for discolouration and remove carbon deposits. The porcelain insulator to the centre electrode circle of the spark plug should be medium brown to light brown.
4. Check the spark plug type and the gap between the electrodes.

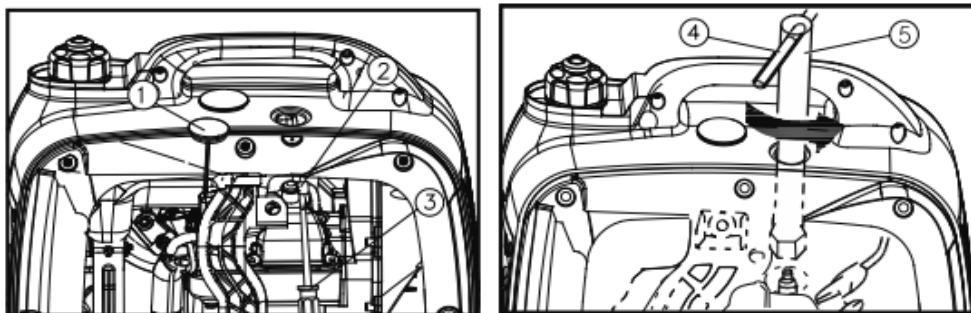

Standard spark plug:

TORCH-A5RTC/E6TC/E6RTC

The gap between the electrodes of the spark plug:

0.6-0.7 mm

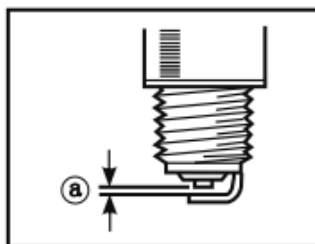

### TIP

The gap between the spark plug electrodes should be measured with a feeler gauge and adjusted to specification if necessary.

1. Screw the spark plug back in.

Spark plug tightening torque: 12.5 N\*m

### TIP

In the absence of a torque wrench, after tightening the candle with your fingers, you must additionally turn it by 1/4 - 1/2 of the turn. However, after such tightening, the spark plug should be tightened to the recommended torque as soon as possible.

2. Install the cap and cover of the spark plugs.

## 7.2 Carburettor adjustment

The carburettor is a very important part of the engine. Carburettor adjustment should be performed by our authorized distributor having the appropriate knowledge and equipment that allows for this operation to be performed properly.

## 7.3 Changing the engine oil

Avoid draining engine oil immediately after stopping engine. The oil is then hot and must be handled with care to avoid burns.

1. Place the generator on a flat surface and warm the engine by running it for a few minutes. Then stop the engine and turn the 3-in-1 switch and the air vent knob on the fuel tank cap to the "OFF" position.
2. Unscrew the screws (1), then remove the cover (2).
3. Remove the oil filler cap (3).
4. Place a drain pan under the engine. Tilt the generator to drain all the oil.
5. Place the generator back on a flat surface.

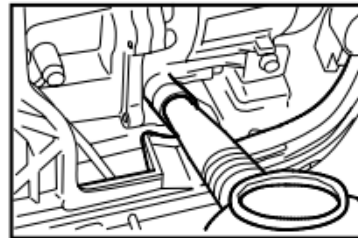
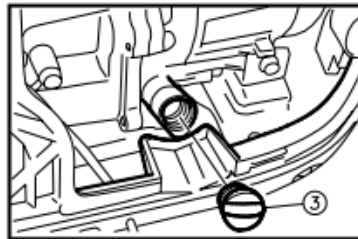
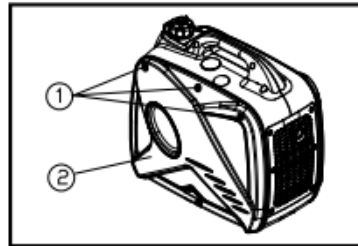

### NOTE

When adding engine oil, do not tilt the generator. This can cause overfilling with oil and damage the engine.

6. Add engine oil to the maximum level.

Recommended engine oil: SAE SJ 15W-40

Recommended engine oil grade: API Service type SE or higher

The amount of engine oil: 0.35 l

7. Wipe the cover clean and wipe up any spilled oil.

### NOTE

Make sure no foreign matter has entered the crankcase.

8. Screw in the oil filler cap.
9. Replace the cover and tighten the screws.

## 7.4 Air filter

1. Loosen the screws (1), and then remove the cover (2).
2. Remove the screw (3), and then remove the air filter housing cover

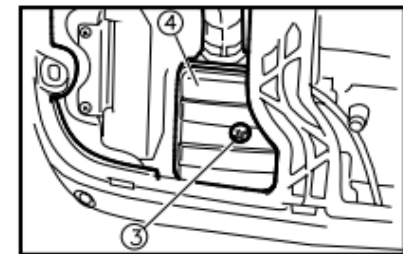
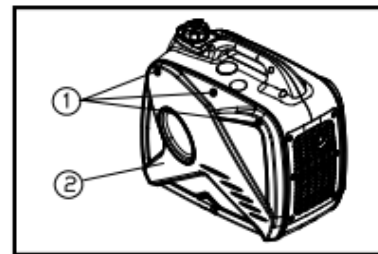

3. Remove the foam element.
4. Wash the foam element with detergent and dry it.
5. Dip the foam element in oil and squeeze out any excess oil.  
The foam element should be wet but no oil should drip from it.

### NOTE

Do not wring out the foam element as it may tear.

6. Insert the foam element into the oil filter housing.

### TIP

Make sure the sealing surface of the foam element fits over the air filter so that unfiltered air is not sucked in.

The engine must not be operated without the foam element, as this can cause excessive wear on the piston and cylinder.

7. Reinstall the air filter housing cover to its original position and tighten the screw.
8. Install the cover and tighten the screws.

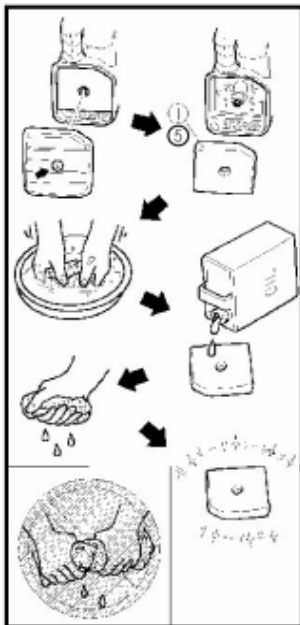

## 7.5 Muffler strainer and spark arrester

### WARNING

After the engine has run, the engine and muffler will be very hot. Avoid touching the engine and muffler until they have cooled down with any part of your body or clothing during maintenance and repairs.

1. Remove the screws (1), and then pull them inward at the areas of the cover (2) shown in the illustration.



2. Loosen the screw (3), then remove the muffler cap (4), muffler strainer (5), and spark arrester (6).
3. Remove any carbon deposits from the engine strainer and spark arrester using a wire brush.

### NOTE

To avoid damaging or scratching the muffler strainer and spark arrester, do not press the wire brush strongly against the parts to be cleaned while cleaning.

4. Check the muffler strainer and spark arrester. Replace them if they are damaged.
5. Install the spark arrester.

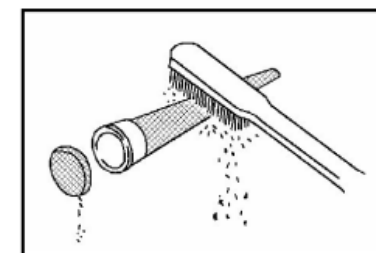

Align the element protruding from the spark arrestor (7) with the opening (8) in the muffler tube.

6. Install the muffler strainer and muffler cap.
7. Install the cover and tighten the screws.

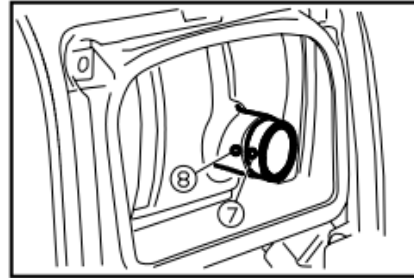

## 7.6 Fuel tank filter

### **WARNING**

Do not use gasoline while smoking or near an open flame.

1. Remove the fuel tank cap and filter.
2. Clean the filter with gasoline.
3. Wipe the filter clean and reinstall it.
4. Install the fuel tank cap.

Make sure the fuel tank cap is tightened securely.

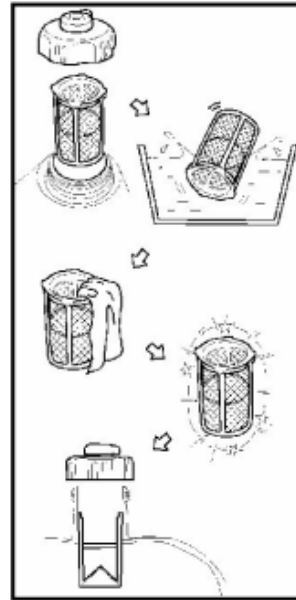

## 7.7 Fuel filter

Remove the screws (1), then remove the cover (2) and drain the fuel (3)

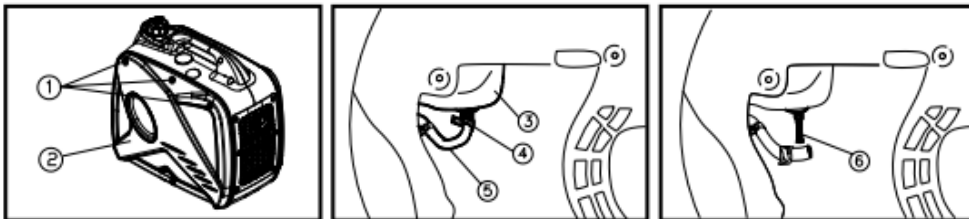

2. Hold and slide up the clamp (4), then remove the hose (5) from the tank.
3. Remove the fuel filter (6).
4. Clean the filter with gasoline.
5. Dry the filter and put it back in the tank.
6. Install the hose and clamp, then open the fuel valve to check for leaks.
7. Install the cover and tighten the screws.

## 8. Storage

Long-term storage of the generator requires certain preventive procedures to prevent its deterioration.

### 8.1 Draining the fuel

1. Set the 3-in-1 switch to the "OFF" position (1).

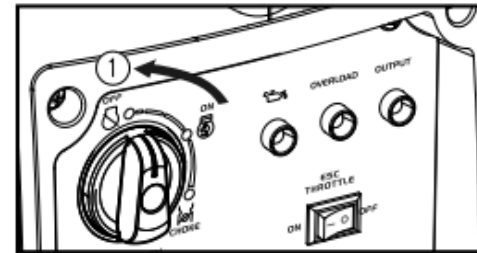

2. Remove the fuel tank cap and filter. Drain the fuel from the tank into an appropriate container. Then tighten the fuel tank cap.

## **WARNING**

Fuel is flammable and poisonous. Please read carefully "SAFETY INFORMATION" (see page 5).

## **NOTE**

Spilled fuel must be wiped up immediately with a clean, dry, soft cloth as it may damage painted surfaces and plastic parts.

1. Start the engine (see page 20) and wait for it to stop. The engine stops after approx. 10-15 minutes due to the using all the fuel.

## **TIP**

- Do not connect any electrical devices during this time. (No-load operation)
  - The running time of the engine depends on the amount of fuel remaining in the tank.
2. Loosen the screws, and then remove the cover.
  3. Drain fuel from the carburettor by unscrewing the drain screw in the carburettor float chamber.
  4. Set the 3-in-1 switch to the "OFF" position.
  5. Tighten the drain screw.
  6. Install the cover and tighten the screws.
  7. Turn the fuel tank cap vent knob to the "OFF" position after the engine has cooled down completely.

## **8.2 Engine**

To protect the cylinder, piston ring, etc. from corrosion, proceed as follows.

1. Remove the spark plug, pour approximately one tablespoon of SAE 15W-40 oil into the spark plug hole, and screw the spark plug back in. Rotate the engine a few times using the starter (with the 3-in-1 switch in "OFF" position) until the cylinder walls are covered with oil.
2. Pull the starter handle until you feel the pressure. Then stop pulling. (This prevents the cylinder and valves from rusting).

Clean the outside of the generator. Store the generator in a dry, well-ventilated place and covered.



## 9. Troubleshooting and fault elimination

### 9.1 Engine cannot be started

#### 1. Fuel system

Fuel is not reaching the combustion chamber.

- No fuel in the tank ... Add fuel.
- The fuel is present in the tank ... Set the ventilator knob in the fuel tank cap and the fuel tap knob to the "ON" position.
- Clogged fuel filter ... Clean the fuel filter.
- Clogged carburetor... Clean the carburetor.

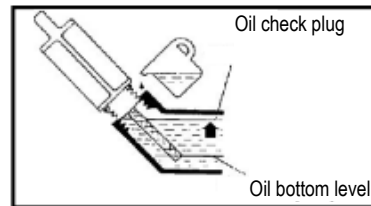

#### 2. Engine oil system

- Not enough oil
- Low oil level... Add engine oil. Electrical systems
- Set the 3-in-1 switch to the "CHOKE" position and pull the starter handle. No spark.
- Spark plug dirty or wet. Remove the carbon build-up or wipe the spark plug dry.
- Ignition system fault. Contact our authorized distributor.

### 9.2 The generator is not producing electricity.

- Set the protection device (DC breaker) to the "OFF" position. Push in the DC breaker so that it is in the "RESET" position.
- The AC pilot light (green) turns off. Stop, and then start the engine.

## 10. Technical specifications

	Model No.	2 kW generator				
Generator	Type	Inverter	Engine	Engine	R80-i	
	Rated frequency (Hz)	50		Type of engine	Single cylinder, 4-stroke, forced air cooled, OHV	
	Rated voltage (V)	220/230/240		Capacity (cc)	79.7	
	Maximum power (kW)	2.0		Type of fuel	Unleaded petrol	
	Rated power (kW)	1.8		Fuel tank capacity (l)	4	
	Power factor	1		Continuous operation time (with rated power) (h)	3.5	
	The quality of the generated alternating current	ISO 8528 G2		Oil capacity (l)	0.35	
	Charging voltage (DC) (V)	12		Spark plug number	TORCH A5RTC	
	Charging current (DC) (A)	8.3		Start-up mode	Recoil starter	
	Overload protection (DC)	Thermal breaker		Generator	Length x width x height (mm)	498 x 290 x 459
	In accordance with the Directive 2000/14/EC and 2005/88/EC				Net weight (kg) - dry	22
Guaranteed sound power: 89 dBA						
Emitted sound pressure level: 68 dBA						
+/-: 2 dBA						

# 11. Cable connection diagram

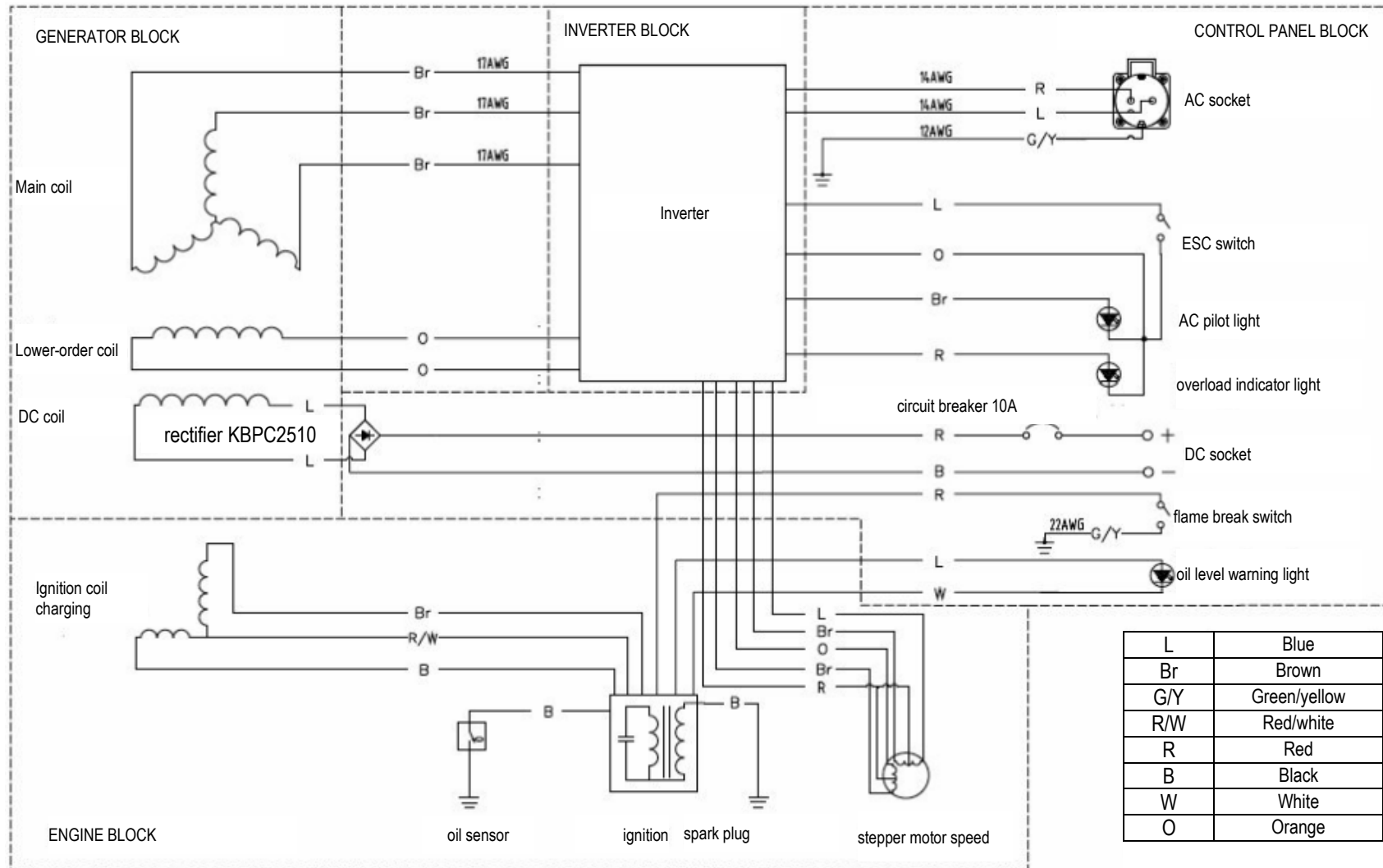



We reserve the right to introduce changes as a part of continuous improvement of our products. All information in this publication is based on product data available at the time of printing. As a result of continuous improvement of our products, some modifications may be introduced, which will be described in future versions of the manual by the services responsible for the change. If you find any transcription errors or inconsistencies in the manual, please report them using the enclosed notification form, or by e-mail: [d.zacharski@fogo.pl](mailto:d.zacharski@fogo.pl) or tel. (65) 534 11 80. No part of this publication may be reproduced without written permission of Fogo Sp. z o.o. This manual is an integral part of the device and must be kept with it, even in case of any resale or disposal of the device.