



Husqvarna®



LC 247, LC 247S, LC 253S, LC 347V, LC 347VE, LC 353V, LC 353VE



EN	Operator's manual	7-23
BG	Ръководство за експлоатация	24-42
CS	Návod k použití	43-59
DA	Brugsanvisning	60-76
DE	Bedienungsanweisung	77-94
EL	Οδηγίες χρήσης	95-113
ES	Manual de usuario	114-131
ET	Kasutusjuhend	132-147
FI	Käyttöohje	148-164
FR	Manuel d'utilisation	165-183
HR	Priručnik za korištenje	184-200
HU	Használati utasítás	201-218
IT	Manuale dell'operatore	219-236
JA	取扱説明書	237-253
LT	Operatoriaus vadovas	254-270
LV	Lietošanas pamācība	271-287
NL	Gebruiksaanwijzing	288-305
NO	Bruksanvisning	306-321
PL	Instrukcja obsługi	322-340
PT	Manual do utilizador	341-358
PT-BR	Manual do operador	359-376
RO	Instrucțiuni de utilizare	377-394
RU	Руководство по эксплуатации	395-413
SK	Návod na obsluhu	414-431
SL	Navodila za uporabo	432-448
SR	Priručnik za rukovaoca	449-465
SV	Bruksanvisning	466-481
TR	Kullanım kılavuzu	482-497
UK	Посібник користувача	498-516
ZH	操作手册	517-531

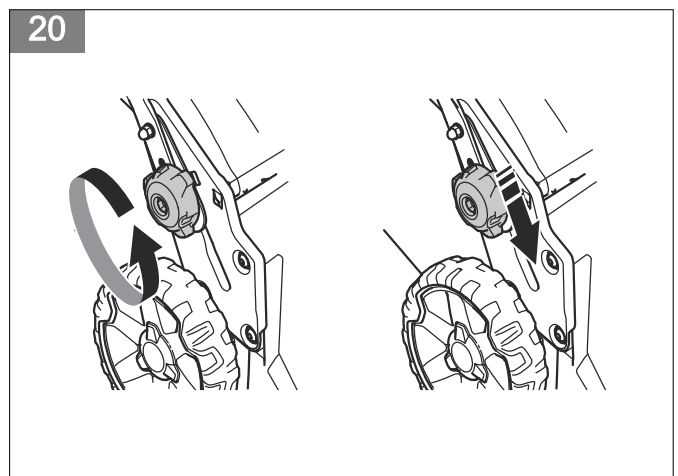
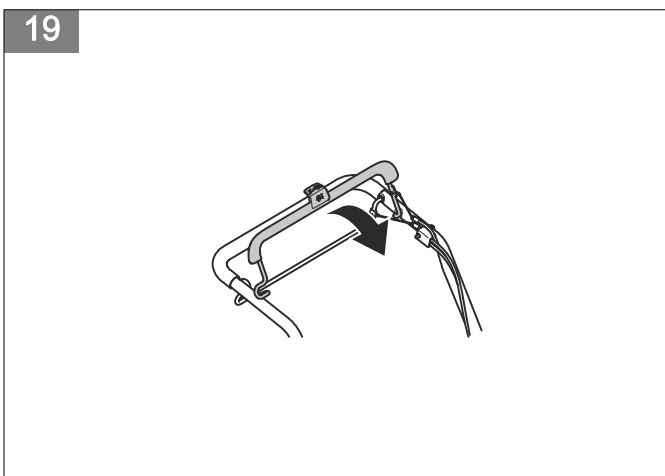
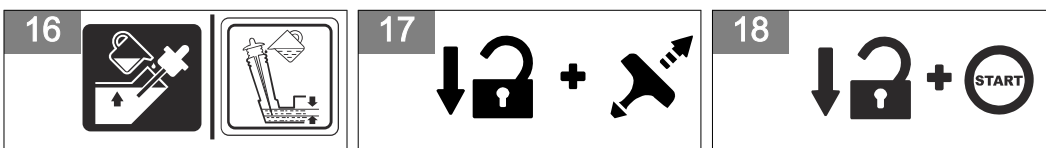
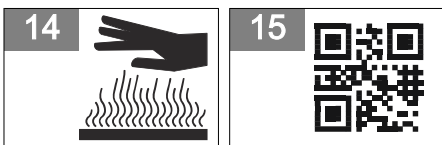
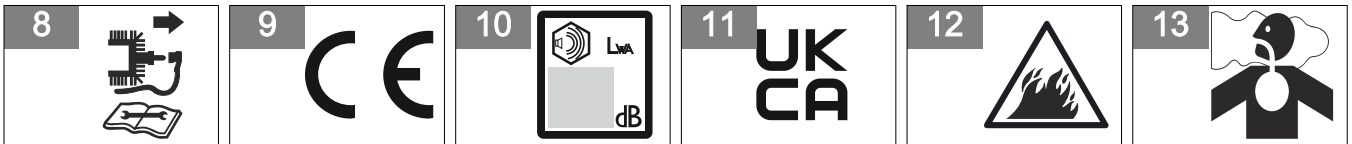
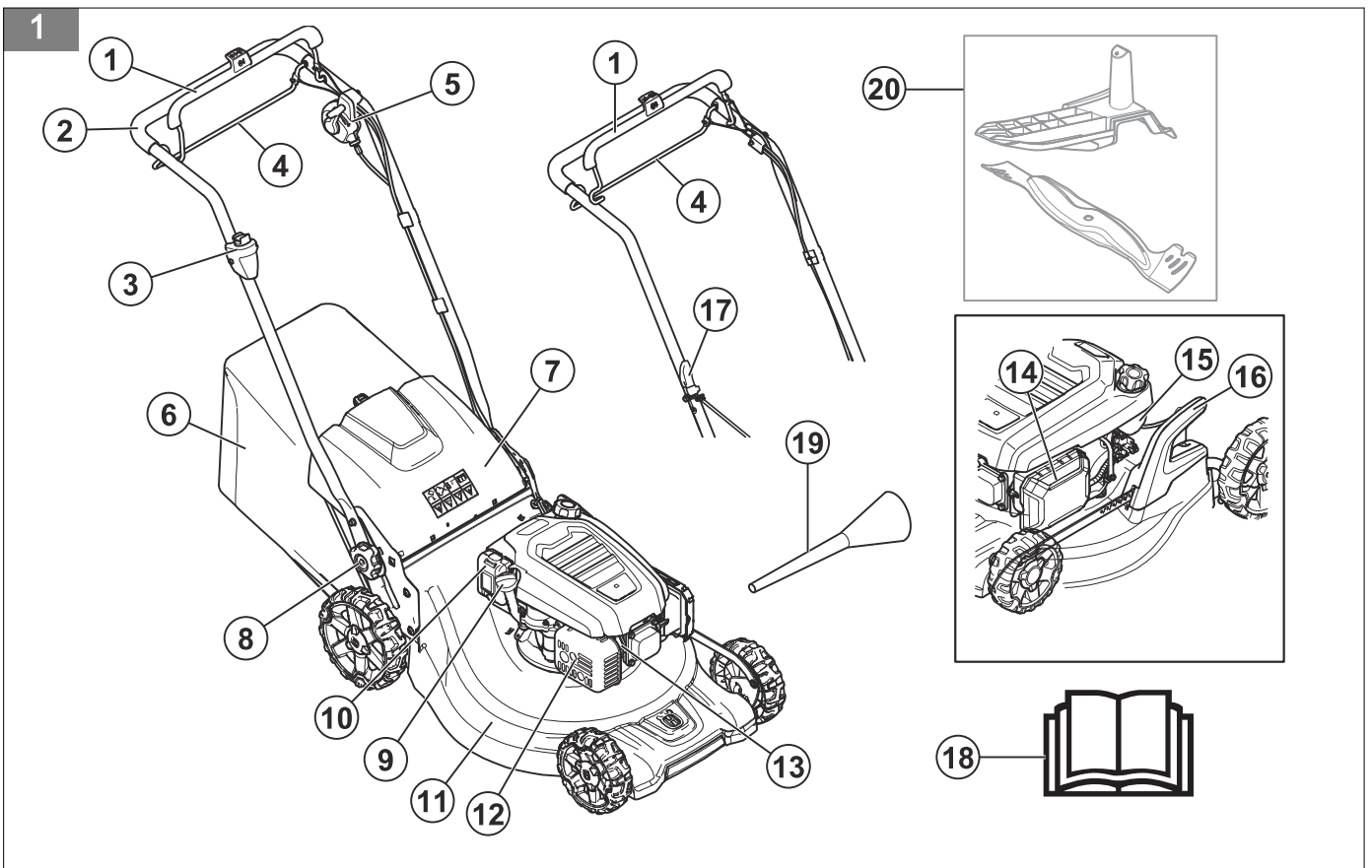

21

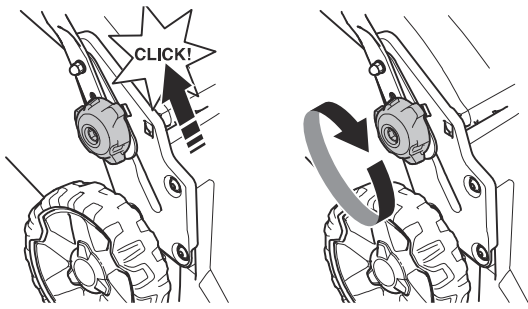

22



23

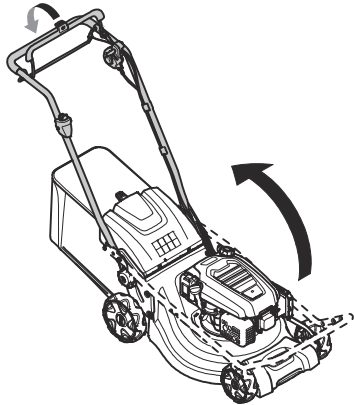

24

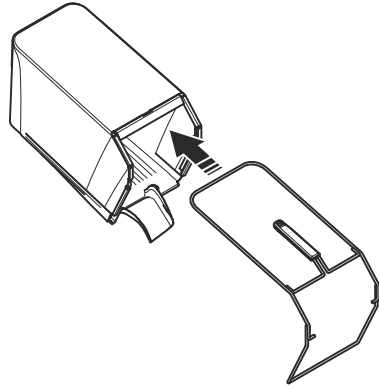

25

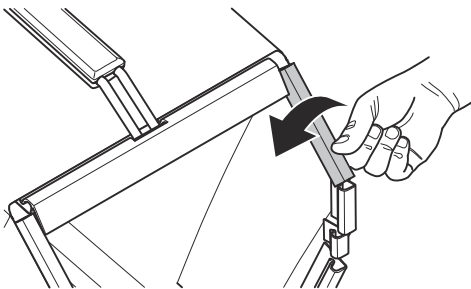

26

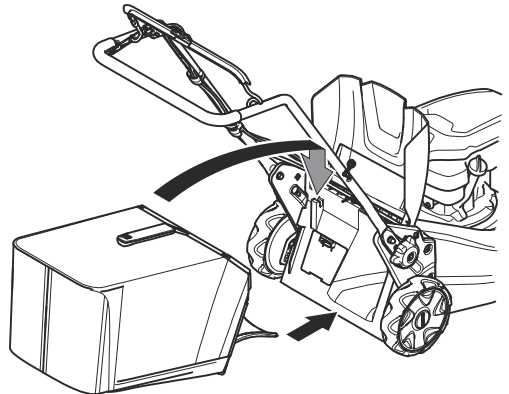

27

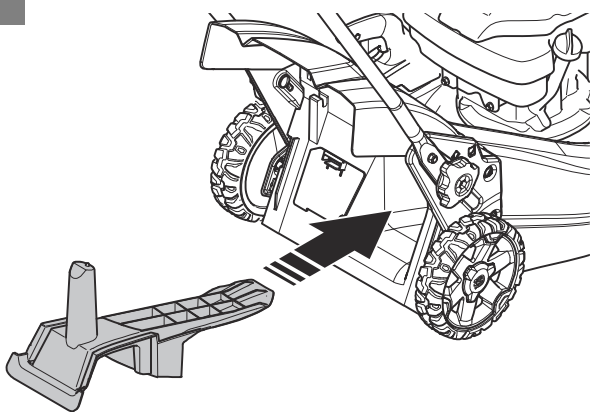

28

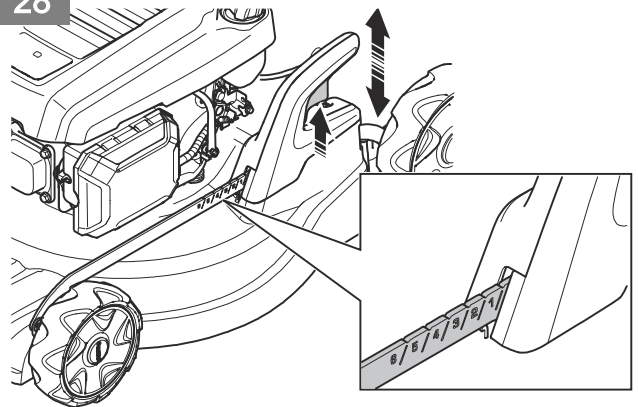

29

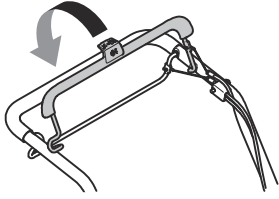

30

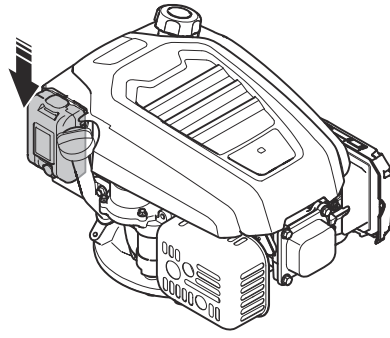

31

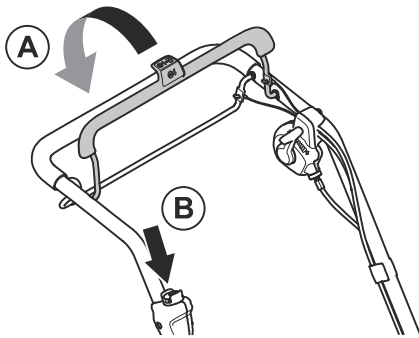

32

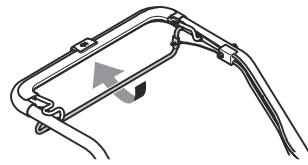

33

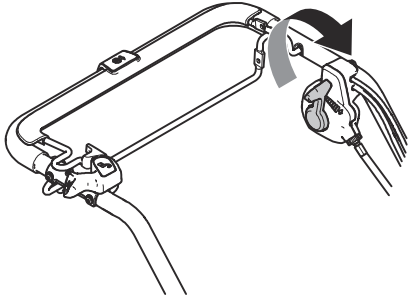

34

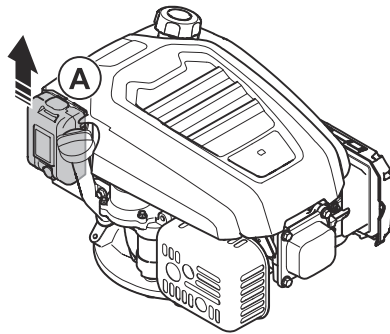

35

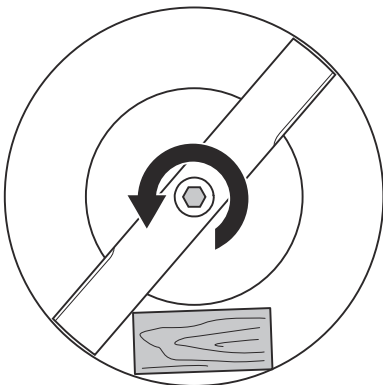

36

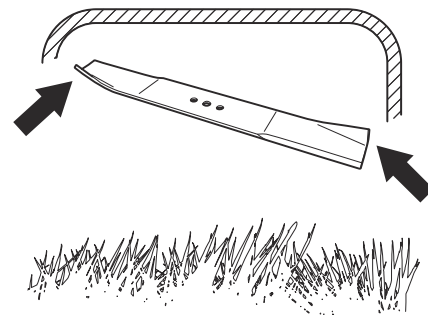

37

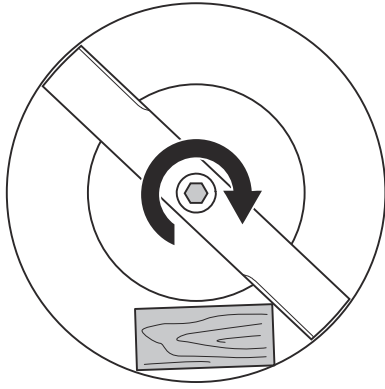

38

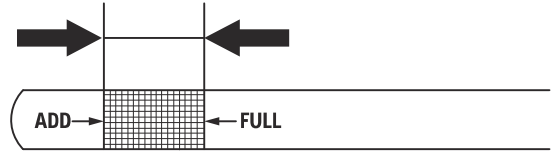

39

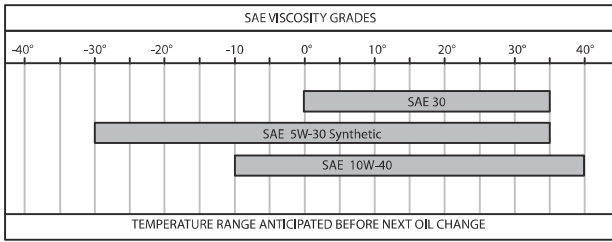

40

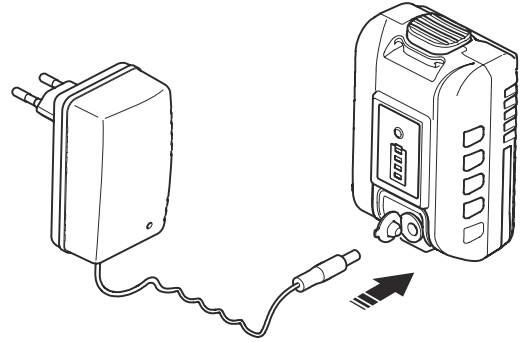

41

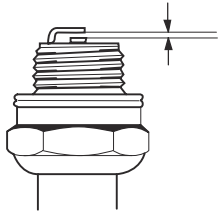

42

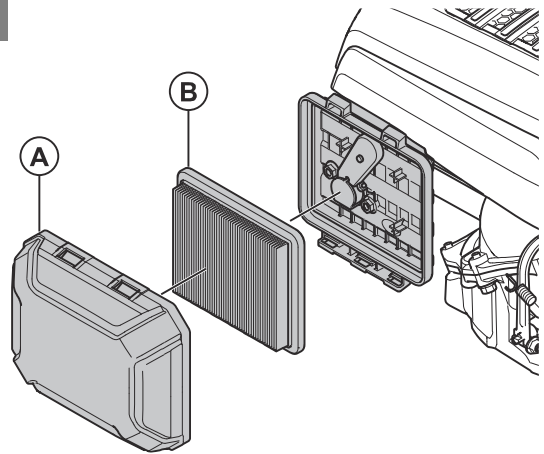

43

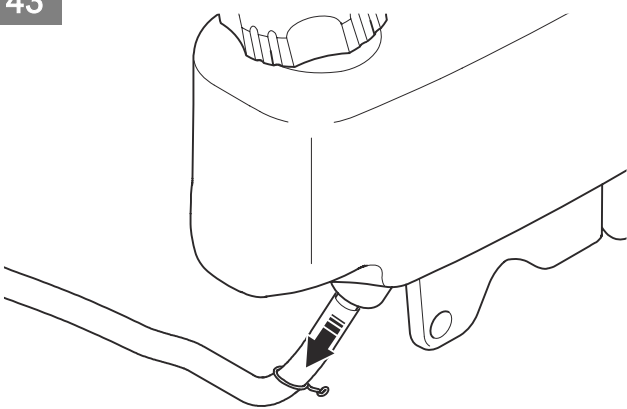

44

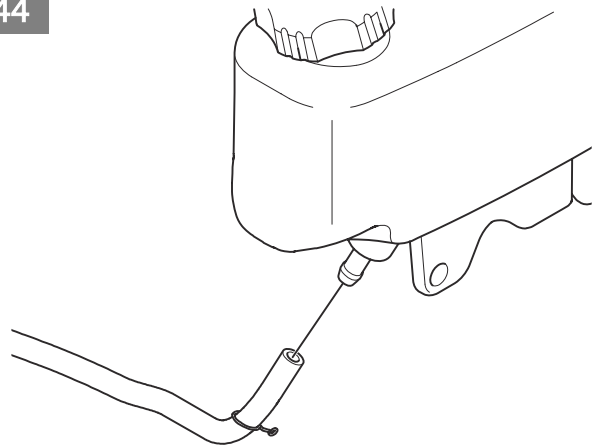

45

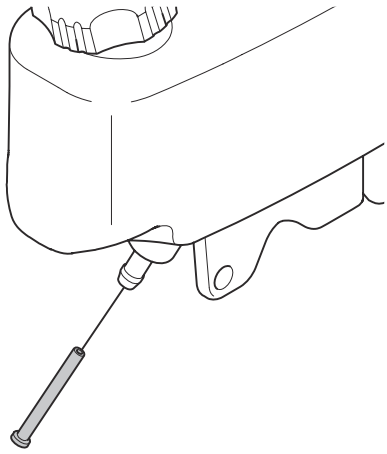

46

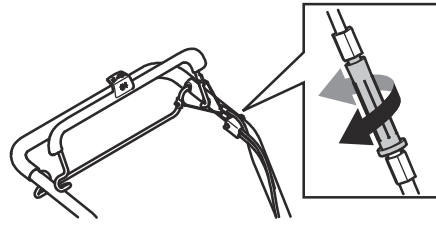

Contents

Introduction.....	7	Engine troubleshooting.....	17
Safety.....	8	Transportation, storage and disposal.....	18
Assembly.....	11	Technical data.....	18
Operation.....	11	Declaration of Conformity.....	22
Maintenance.....	13		

Introduction

Product description

The product is a pedestrian-controlled rotary lawn mower. The grass is collected in a grass catcher. Remove the grass catcher to get rear discharge of the grass. Attach a mulch kit (accessory) to cut the grass into fertilizer.

Intended use

Use the product to cut grass. Do not use the product for other tasks.

Product overview

(Fig. 1)

1. Engine brake handle
2. Upper handle
3. Electrical starter button (LC 347VE, LC 353VE)
4. Drive bail (LC 247S, LC 253S, LC 347V, LC 347VE, LC 353V, LC 353VE)
5. Speed control
6. Grass catcher
7. Rear cover
8. Handle height adjustment
9. Oil cap and dipstick
10. Battery, safety device (LC 347VE, LC 353VE)
11. Cutting cover
12. Muffler
13. Spark plug
14. Air filter
15. Fuel tank cap
16. Cutting height adjusters
17. Starter rope handle (LC 247, LC 247S, LC 253S, LC 347V, LC 353V)
18. Operator's manual
19. Oil funnel (LC 247, LC 247S)
20. Mulch kit (Accessory)

(Fig. 4)

Look out for thrown objects and ricochets.

(Fig. 5)

Keep persons and animals at a safe distance from the work area.

(Fig. 6)

Warning: Keep hands and feet away from the rotating blade.

(Fig. 7)

Warning: Keep hands and feet away from rotating parts.

(Fig. 8)

Stop the engine and remove the ignition cable before repairs or maintenance.

(Fig. 9)

This product is in accordance with applicable EC directives.

(Fig. 10)

Noise emission to the environment label as per EU and UK directives and regulations, and New South Wales legislation "Protection of the Environment Operations (Noise Control) Regulation 2017". The guaranteed sound power level of the product is specified in *Technical data on page 18* and on the label.

Symbols on the product

(Fig. 2)

WARNING! Be careful and use the product correctly. This product can cause serious injury or death to the operator or others.

(Fig. 11)

This product conforms to applicable UK regulations.

(Fig. 12)

Risk of fire.

(Fig. 3)

Please read the operator's manual carefully and make sure that you understand the instructions before use.

(Fig. 13)

Do not breathe in exhaust fumes. The exhaust fumes from the engine contain carbon monoxide, an odourless, poisonous and very dangerous gas. Do not start the engine indoors or in closed spaces.

- (Fig. 14) Hot surface.
- (Fig. 16) Fill the engine with oil before you start the product.
- (Fig. 17) Start procedure for LC 247, LC 247S, LC 253S, LC 347V, LC 353V: Push the engine brake handle down and pull the starter rope handle.
- (Fig. 18) Start procedure for LC 347VE, LC 353VE: Push the engine brake handle down and push the start button.
- (Fig. 15) Scannable code.

Note: Other symbols/decals on the product refer to certification requirements for other commercial areas.

Euro V Emissions



WARNING: Tampering with the engine voids the EU type-approval of this product.

Product damage

We are not responsible for damages to our product if:

- the product is incorrectly repaired.
- the product is repaired with parts that are not from the manufacturer or not approved by the manufacturer.
- the product has an accessory that is not from the manufacturer or not approved by the manufacturer.
- the product is not repaired at an approved service center or by an approved authority.

Safety

Safety definitions

Warnings, cautions and notes are used to point out specially important parts of the manual.



WARNING: Used if there is a risk of injury or death for the operator or bystanders if the instructions in the manual are not obeyed.



CAUTION: Used if there is a risk of damage to the product, other materials or the adjacent area if the instructions in the manual are not obeyed.

Note: Used to give more information that is necessary in a given situation.

General safety instructions



WARNING: Read the warning instructions that follow before you use the product.

- This product is dangerous if used incorrectly or if you are not careful. Injury or death can occur if you do not obey the safety instructions.
- This product produces an electromagnetic field during operation. This field may under some circumstances interfere with active or passive medical implants. To reduce the risk of serious or fatal injury we recommend persons with medical

implants to consult their physician and the medical implant manufacturer before operating this product.

- Always be careful and use your common sense. If you are not sure how to operate the product in a special situation, stop and speak to your Husqvarna dealer before you continue.
- Keep in mind that the operator will be held responsible for accidents that involve other persons or their property.
- Keep the product clean. Make sure that you can clearly read signs and decals.
- Do not let a person use the product unless you make sure that they read and understand the contents of the operator's manual.
- Do not let a child operate the product.
- Keep children away from the work area. A responsible adult must be there at all times.
- Do not let a person, without knowledge of the instructions, operate the product.
- Always monitor a person, with decreased physical capacity or mental capacity, that uses the product. A responsible adult must be there at all times.
- Do not use the product if you are tired, ill, or under the influence of alcohol, drugs or medicine. This has a negative effect on your vision, alertness, coordination and judgment.
- Do not use a product that is damaged or does not operate correctly.
- Do not change this product or use it if it is possible that it has been changed by others.
- Do not change the adjustment for the engine speed control.

Work area safety



WARNING: Read the warning instructions that follow before you use the product.

- Remove objects such as branches, twigs and stones from the work area before you use the product.
- Objects that hit against the cutting equipment can eject and cause damage to persons and objects. Keep bystanders and animals at a safe distance from the product.
- Never use the product in bad weather such as fog, rain, strong winds, intense cold and risk of lightning. To use the product in bad weather or in moist or wet locations is tiring. Bad weather can cause dangerous conditions, such as slippery surfaces.
- Look out for persons, objects and situations that can prevent safe operation of the product.
- Look out for obstacles, such as roots, stones, twigs, pits and ditches. Long grass can hide obstacles.
- To cut grass on slopes can be dangerous. Do not use the product on ground that slopes more than 15°.
- Operate the product across the face of slopes. Do not move up and down.
- Be careful when you go near hidden corners and objects that prevent a clear view.

Work safety



WARNING: Read the warning instructions that follow before you use the product.

- Use this product to cut grass lawns only. It is not permitted to use it for other tasks.
- Use personal protective equipment. Refer to *Personal protective equipment on page 9*.
- Make sure that you know how to stop the engine quickly in an emergency.
- Never start the engine in a closed space or near flammable material. The exhaust fumes from the engine are hot and can contain sparks which can start a fire.
- Do not operate the product unless the blade and all covers are attached correctly. An incorrectly attached blade can come loose and cause personal injury.
- Make sure that the blade does not hit objects such as stones and roots. This can do damage to the blade and bend the engine shaft. A bent axle causes heavy vibration and a very high risk that the blade becomes loose.
- If the blade hits an object or if vibrations occur, stop the product immediately. Disconnect the ignition cable from the spark plug. Examine the product for damages. Repair damages or let an authorised service agent do the repair.

- Never attach the engine brake handle permanently to the handle when the engine is started.
- Put the product on a stable, flat surface and start it. Make sure that the blade does not hit the ground or other objects.
- Always stay behind the product when you operate it.
- Let all the wheels stay on the ground and keep 2 hands on the handle when you operate the product. Keep your hands and feet away from the rotating blades.
- Do not tilt the product when the engine is started.
- Be careful when you pull the product rearward.
- Never lift up the product when the engine is started. If you must lift the product, first stop the engine and disconnect the ignition cable from the spark plug.
- Do not walk rearward when you operate the product.
- Stop the engine when you move across areas without grass, for example paths made of gravel, stone and asphalt.
- Do not run with the product when the engine is started. Always walk when you operate the product.
- Stop the engine before you change the cutting height. Never make adjustments with the engine started.
- Never let the product stay out of view with the engine started. Stop the engine and make sure that the cutting equipment does not rotate.

Safety instructions for operation

Personal protective equipment



WARNING: Read the warning instructions that follow before you use the product.

- Personal protective equipment cannot fully prevent injury but it decreases the degree of injury if an accident does occur. Let your dealer help you select the right equipment.
- Use hearing protection if the noise level is higher than 85 dB.
- Use heavy-duty slip-resistant boots or shoes. Do not use open shoes or go with bare feet.
- Use heavy, long pants.
- Use protective gloves when necessary, for example when you attach, examine or clean the cutting equipment.

Safety devices on the product



WARNING: Read the warning instructions that follow before you use the product.

- Do not use a product with safety devices that are damaged or do not operate correctly.

- Do a check of the safety devices regularly. If the safety devices are damaged or do not operate correctly, speak to your Husqvarna servicing dealer.
- Do not make modifications to safety devices.

To do a check of the cutting cover

The cutting cover decreases vibrations in the product and decreases the risk of injury from the blade.

- Examine the cutting cover to make sure that there are no damages such as cracks.

Battery (LC 347VE, LC 353VE)



WARNING: A damaged battery decreases the safety of the product. Always use a battery approved by the manufacturer.

The battery gives power to the electrical start and is a safety device that prevents accidental start. Remove the battery when you do not operate the product and when you let it stay out of view.

To do a check of the engine brake handle

The engine brake handle stops the engine. When the engine brake handle is released, the engine stops.

- Start the engine and then release the engine brake handle. If the engine does not stop in 3 seconds, let an approved Husqvarna service agent adjust the engine brake. (Fig. 19)

Muffler

The muffler keeps the noise levels to a minimum and sends the exhaust fumes away from the operator.

Do not use the product if the muffler is missing or damaged. A damaged muffler increases the noise level and the risk of fire.



WARNING: The muffler becomes very hot during and after use and when the engine operates at idle speed. Be careful near flammable materials and/or fumes to prevent fire.

To do a check of the muffler

- Examine the muffler regularly to make sure that it is attached correctly and not damaged.

Fuel safety



WARNING: Read the warning instructions that follow before you use the product.

- Do not start the product if there is fuel or engine oil on the product. Remove the unwanted fuel/oil and let the product dry.

- If you spill fuel on your clothing, change clothing immediately.
- Do not get fuel on your body, it can cause injury. If you get fuel on your body, use soap and water to remove the fuel.
- Do not start the product if the engine has a leak. Examine the engine for leaks regularly.
- Be careful with fuel. Fuel is flammable and the fumes are explosive and can cause injuries or death.
- Do not breathe in the fuel fumes, it can cause injury. Make sure that there is a sufficient airflow.
- Do not smoke near the fuel or the engine.
- Do not put warm objects near the fuel or the engine.
- Do not add the fuel when the engine is on.
- Make sure that the engine is cool before you refuel.
- Before you refuel, open the fuel tank cap slowly and release the pressure carefully.
- Do not add fuel to the engine in an indoor area. Not sufficient airflow can cause injury or death because of asphyxiation or carbon monoxide.
- Tighten the fuel tank cap fully. If the fuel tank cap is not tightened, there is a risk of fire.
- Move the product a minimum of 3 m / 10 ft from the position where you filled the tank before a start.
- Do not fill the fuel tank fully. Heat causes the fuel to expand. Keep a space at the top of the fuel tank.
- Never store the product with fuel in the fuel tank inside a building where ignition sources are present such as hot water heaters, space heaters or clothes dryers. Allow the engine to cool Before storing in any enclosure.

Safety instructions for maintenance



WARNING: Read the warning instructions that follow before you use the product.

- The exhaust fumes from the engine contain carbon monoxide, an odourless, poisonous and very dangerous gas. Do not start the engine indoors or in closed spaces.
- Before you do the maintenance on the product, stop the engine and remove the ignition cable from the spark plug. On LC 347VE, LC 353VE, also remove the battery.
- Use protective gloves when you do maintenance on the cutting equipment. The blade is very sharp and cuts can easily occur.
- Accessories and changes to the product that are not approved by the manufacturer, can cause serious injury or death. Do not change the product. Always use accessories that are approved by the manufacturer.
- If the maintenance is not done correctly and regularly, the risk of injury and damage to the product increases.

- Only do the maintenance as given in this owner's manual. All other servicing must be done by an approved Husqvarna service agent.
- Let an approved Husqvarna service agent do servicing on the product regularly.
- Replace damaged, worn or broken parts.

Assembly

Introduction



WARNING: Before you assemble the product, read the safety chapter. On LC 347VE, LC 353VE, also remove the battery.

To adjust the handle

1. Loosen the lower knobs.
2. Move the knobs to the lower end of the grooves on the left and the right side of the product. (Fig. 20)
3. Set the handle height in one of the 2 available positions.
4. Move the knobs up in the direction of the handle until they stop and you hear a click. (Fig. 21)
5. Tighten the knobs fully.

To set the product in transport position

1. Loosen the lower knobs.
2. Move the knobs to the lower end of the grooves on the left and the right side of the product. (Fig. 20)
3. Fold the handle forward. (Fig. 22)

To set the product in operation position

1. Fold the handle to upright position. (Fig. 23)
2. Move the knobs up in the direction of the handle until they stop and you hear a click. (Fig. 21)
3. Tighten the knobs fully.

To assemble the grass catcher

1. Attach the grass catcher frame to the grass bag with the rigid part of the bag on the bottom. Keep the handle of the frame on top of the grass bag. (Fig. 24)

2. Attach the bottom section of the grass catcher frame in the groove on the bottom of the grass catcher.
3. Attach the grass bag to the grass catcher frame with the clips. (Fig. 25)
4. Lift the rear cover.
5. Attach the grass catcher to the top edge of the chassis.
6. Put the lower part of the grass catcher into the grass discharge channel. (Fig. 26)

To assemble the mulch plug (accessory)

1. Lift up the rear cover and remove the grass catcher.
2. Put the mulch plug into the discharge channel. (Fig. 27)
3. Replace the blade with the mulch blade that is supplied in the mulch kit. Refer to *Technical data on page 18*.

To cut grass without a grass catcher or mulch plug attached

- Lift up the rear cover and remove the grass catcher.
- If a mulch plug and a mulch blade are attached, remove them.
- Close the rear cover before you operate the product.

When you operate the product, the cut grass discharges below the rear cover.

Operation

Introduction



WARNING: Before you operate the product, you must read and understand the safety chapter.

Husqvarna Connect

Husqvarna Connect is a free app for your mobile device. The Husqvarna Connect app gives extended functions for your Husqvarna product:

- Extended product information.
- Information about, and help with, product parts and servicing.

To start to use Husqvarna Connect

1. Download the Husqvarna Connect app on your mobile device.
2. Register in the Husqvarna Connect app.
3. Follow the instruction steps in the Husqvarna Connect app to connect and register the product.

Note: Husqvarna Connect app is not available for download in all markets. Speak to your servicing dealer for more information.

Before you operate the product

1. Read the operator's manual carefully and make sure that you understand the instructions.
2. Examine the cutting equipment to make sure that it is correctly attached and adjusted. Refer to *To examine the cutting equipment on page 14*.
3. Do a check of the oil level and fill with engine oil if it is necessary. Refer to *To do a check of the oil level on page 14*.
4. Fill the fuel tank. Refer to *To fill fuel on page 12*.

To fill fuel

If available, use low-emission/alkylate gasoline. If low-emission/alkylate gasoline is not available, use good quality unleaded gasoline or leaded gasoline with octane number not less than 90.



CAUTION: Do not use gasoline with an octane number less than 90 RON (87 AKI). This can cause damage to the product.

1. Open the fuel tank cap slowly to release the pressure.
2. Fill slowly with a fuel can. If you spill fuel, remove it with a cloth and let remaining fuel dry off.
3. Clean the area around the fuel tank cap.
4. Tighten the fuel tank cap fully. If the fuel tank cap is not tightened, there is a risk of fire.
5. Move the product a minimum of 3 m (10 ft) from the position where you filled the tank before a start.

To set the cutting height

The cutting height can be adjusted in 6 levels.

1. Move the cutting height lever rearward to decrease the cutting height.
2. Move the cutting height lever forward to increase the cutting height. (Fig. 28)



CAUTION: Do not set the cutting height too low. The blades can hit the ground if the surface of the lawn is not level.

To start the product

- Make sure that the ignition cable is connected to the spark plug.

Manual start (LC 247, LC 247S, LC 253S, LC 347V, LC 353V)

1. Stay behind the product.

2. Hold the engine brake handle against the handlebar. (Fig. 29)
3. Hold the starter rope handle with your right hand.
4. Slowly pull out the starter rope until you feel some resistance.
5. Pull with force to start the engine.



WARNING: Do not twist the starter rope around your hand.

Electrical start (LC 347VE, LC 353VE)

1. Make sure that the battery is charged. Refer to *To use the battery for the first time on page 15*.
2. Attach the battery to the engine. The battery locks into position when you hear a click. (Fig. 30)
3. Stay behind the product and hold the engine brake handle (A) against the handlebar. (Fig. 31)
4. Push and hold the electrical start button (B) for 3-5 seconds. The engine starts.

Note: If the engine does not start, wait 1 minute and try to start the product again.

To use the drive on the wheels

- For models with drive bail, pull the drive bail in the direction of the upper handle. (Fig. 32)
- For models with speed control, move the speed control lever forward to increase the speed and rearward to decrease the speed. (Fig. 33)
- Before you pull the product rearward, disengage the drive and push the product forward approximately 10 cm.
- Release the drive bail to disengage the drive, for example when you go near an obstacle.

To stop the product

- To stop the engine, release the engine brake handle.

To remove the battery (LC 347VE & LC 353VE)

To prevent accidental start of the engine, remove the battery when the product is not in operation.

- Push the lock button (A) and pull the battery straight out. (Fig. 34)

To get a good result

- Always use a sharp blade. A blunt blade gives an irregular result and the cut surface of the grass becomes yellow. A sharp blade also uses less energy than a blunt blade.

- Do not cut more than $\frac{1}{3}$ of the length of the grass. Cut first with the cutting height set high. Examine the result and lower the cutting height to an applicable level. If the grass is very long, drive slowly and cut 2 times if necessary.
- Cut in different directions each time to prevent stripes in the lawn.
- Keep the cutting cover clean. Buildup from grass and dirt on the inner side of the cutting cover can decrease the cutting result. Refer to *To clean the inner surface of the cutting cover on page 14.*

Maintenance

Introduction



WARNING: Before you do maintenance, you must read and understand the safety chapter.

For all servicing and repair work on the product, special training is necessary. We guarantee the availability of professional repairs and servicing. If your dealer is not a service agent, speak to them for information about the nearest service agent.

For more detailed information, refer to www.husqvarna.com.

Maintenance schedule



CAUTION: Make sure that the air filter is up and not against the ground when you tilt the product. Risk of engine damage.



CAUTION: For models with electrical start, remove the battery before you do maintenance, repairs or clean the product.

The maintenance intervals are calculated from daily use of the product. The intervals change if the product is not used daily.

For maintenance identified with * see instructions in *Maintenance on page 13.*

Maintenance	Daily	Monthly	Each season
Do a general inspection	X		
Examine the oil level	X		
Replace the oil (the first time after 5 h of use, then after each 50 h of use) ¹			X
Clean the product	X		
Examine the cutting equipment	X		
Examine the cutting cover *	X		
Examine the engine brake handle *	X		
Examine the muffler *		X	
Examine the spark plug. Clean or replace the spark plug if it is necessary			X
Examine the air filter	X		
Clean the air filter ²		X	
Replace the air filter			X

¹ If the product is operated with heavy load or in high ambient temperatures, replace the engine oil each 25 hours.

² Clean more often under dusty conditions or when airborne debris is present. Replace air filter, if it is very dirty.

Maintenance	Daily	Monthly	Each season
Examine the fuel system			X
Clean the cooling fins on the cylinder		X	
Examine and adjust the clutch wire. (LC 247S, LC 253S, LC 347V, LC 347VE, LC 353V, LC 353VE)			X

To do a general inspection

- Make sure that all nuts and screws on the product are tightened correctly.

To clean the product externally

- Use a brush to remove leaves, grass and dirt.
- Make sure that the air intake on the top of the engine is not blocked.
- Do not use a high pressure washer to clean the product.
- If you use water to clean the product, do not flush water directly on the engine.

To clean the inner surface of the cutting cover

1. Empty the fuel tank.
2. Put the product on its side with the muffler down.



CAUTION: If the product is put with the air filter down, the engine can become damaged.

3. Hose down the inner surface of the cutting cover with water.

To examine the cutting equipment



WARNING: To prevent accidental start remove the ignition cable from the spark plug.



WARNING: Use protective gloves when you do maintenance on the cutting equipment. The blade is very sharp and cuts can easily occur.

1. Examine the cutting equipment for damage or cracks. Always replace a damaged cutting equipment.
2. Look at the blade to see if it is damaged or blunt.

Note: It is necessary to balance the blade after it is sharpened. Let a service center sharpen, replace and balance the blade. If you hit an obstacle that causes the product to stop, replace the damaged blade. Let the service center estimate if the blade can be sharpened or must be replaced.

To replace the blade

1. Lock the blade with a block of wood. (Fig. 35)
2. Remove the blade bolt and spring washer.
3. Remove the blade.
4. Examine the blade support and blade bolt to see if there are damages.
5. Examine the engine shaft to make sure that it is not bent.
6. When you attach the new blade, point the angled ends of the blade in the direction of the cutting cover. (Fig. 36)
7. Make sure that the blade is aligned with the center of the engine shaft.
8. Lock the blade with a block of wood. Attach the spring washer and tighten the bolt and washer with a torque of 70 Nm. (Fig. 37)
9. Pull the blade around by hand and make sure that it turns freely.



WARNING: Use heavy duty gloves. The blade is very sharp and cuts can easily occur.

10. Start the product to do a test of the blade. If the blade is not correctly attached, there is vibration in the product or the cutting result is unsatisfactory.

To do a check of the oil level



CAUTION: A too low oil level can do damage to the engine. Do a check of the oil level before you start the product.

1. Put the product on level ground.
2. Remove the oil tank cap and the attached dipstick.
3. Clean the oil from the dipstick.
4. Push the dipstick fully into the oil tank.
 - a) Do not attach the oil tank cap on LC 247, LC 247S.
 - b) Attach the oil tank cap on LC 253S, LC 347V, LC 347VE, LC 353V, LC 353VE.
5. Remove the oil tank cap and the dipstick.
6. Examine the oil level on the attached dipstick.
7. If the oil level is low, fill with engine oil and do a check of the oil level again. (Fig. 38)

Note: Use a funnel to prevent spill.

8. Install the oil tank cap when the oil level is correct.

To replace the engine oil



WARNING: Engine oil is very hot directly after the engine is stopped. Let the engine become cool before you drain the engine oil. If you spill engine oil on your skin, clean with soap and water.

(Fig. 39)

1. Operate the product until the fuel tank is empty.
2. Remove the ignition cable from the spark plug.
3. Remove the oil tank cap and the attached dipstick.
4. Put a container below the product to collect the engine oil in.
5. Tilt the product or drain the engine oil from the oil tank with an oil pump (accessory).
6. Fill with new engine oil of the type recommended in *Technical data on page 18*.
7. Do a check of the oil level. Refer to *To do a check of the oil level on page 14*.
8. Install the oil tank cap when the oil level is correct.

Battery (LC 347VE, LC 353VE)



WARNING: A damaged battery decreases the safety of the product. Always use a battery approved by the manufacturer.

The battery gives power to the electrical start and is a safety device that prevents accidental start. Remove the battery when you do not operate the product and when you let it stay out of view.

To use the battery for the first time



CAUTION: Do not let the battery become empty. If the battery becomes empty, it can cause damage to the battery.

You must charge the battery before first operation.

1. Connect the battery charger to the battery, refer to *To charge the battery on page 15*.
2. Wait until a minimum of 1 green LED comes on.
3. Attach the battery to the engine, refer to *Electrical start (LC 347VE, LC 353VE) on page 12*.

To charge the battery

If only 1 or 0 lamp indicators on the battery are on, it is necessary to charge it. An empty battery is fully charged in 2 hours. To charge for shorter periods of time does not do damage to the battery.

1. Connect the battery charger to the battery. (Fig. 40)
2. Connect the battery charger to a power socket, 100-240V, 50-60Hz.
3. Remove the charger from the power socket first, then remove the charger from the battery.

Status for battery charge

LED display on the battery	Status
LED 1 flashes red.	1%-9%
LED 1 is constant red.	10%-32%
LED 1 is green and LED 2 is red.	33%-54%
LED 1 and 2 are green and LED 3 is red.	55%-77%
LED 1, 2 and 3 are green and LED 4 is red.	78%-100%

Lamp indicator on the battery charger	Status
Constant red light	The battery charges.
Constant green light	The battery is fully charged.

To do a check of the spark plug



CAUTION: Always use the recommended spark plug type. Incorrect spark plug type can cause damage to the product.

- Do a check of the spark plug if the engine is low on power, is not easy to start or does not operate correctly at idle speed.
- To decrease the risk of unwanted material on the spark plug electrodes, obey these instructions:
 - a) Make sure that the idle speed is correctly adjusted.
 - b) Make sure that the fuel mixture is correct.
 - c) Make sure that the air filter is clean.
- If the spark plug is dirty, clean it and make sure that the electrode gap is correct, refer to *Technical data on page 18*. (Fig. 41)
- Replace the spark plug if it is necessary.

Air filter

A dirty air filter can cause the engine to be damaged or not operate correctly. Do maintenance on the air filter more frequently in dusty conditions. Refer to *Maintenance schedule on page 13* for information about when to replace the air filter.

Note: Always replace a damaged air filter.

To remove and install the air filter (LC 253S, LC 347V, LC 347VE, LC 353V, LC 353VE)



WARNING: Use protective gloves.

1. Push the clips on the air filter cover.
2. Carefully remove the air filter cover (A) from the engine.
3. Remove the air filter (B). (Fig. 42)
4. Examine the air filter for damages. Replace a damaged air filter.
5. Clean and examine the air filter. Refer to *To clean the air filter on page 16*.
6. Install in the opposite sequence.

To clean the air filter

A dirty air filter can cause the engine to be damaged or not operate correctly. Do maintenance on the air cleaner more frequently in dusty conditions.

Refer to *Maintenance schedule on page 13* for information about when to replace the air filter.

1. Remove the air filter cover and remove the filter.
2. Clean the filter by hitting it against a flat surface. Do not use solvent with petroleum, kerosene or compressed air to clean the filter.

Note: Air filters in operation for a long time cannot be cleaned fully. Replace the air filter at regular intervals. Damaged air filters must always be replaced.

3. When you assemble the air filter, make sure that it fully seals against the filter holder.

To examine the fuel system

- Examine the fuel tank cap and the seal for the fuel tank cap to make sure that there are no damages.
- Examine the fuel hose to make sure that there are no leaks. If the fuel hose is damaged, let a service agent replace it.

To drain the fuel tank

1. Put a container below the fuel tank.
2. Remove the fuel tank cap.
3. Push the hose clips on the fuel hose against the carburetor.
4. Remove the fuel hose from the carburetor.

5. Put the fuel tank hose in the container and remove the hose clips.
6. Tilt the product and drain the fuel into the container.

To replace the fuel filter



WARNING: Use protective gloves.

1. Drain the fuel tank.
2. Move the hose clip away from the fuel tank. (Fig. 43)
3. Remove the fuel hose from the fuel tank. A small quantity of fuel can leak. (Fig. 44)
4. Remove the fuel filter from the fuel tank. (Fig. 45)
5. Install a new fuel filter in the fuel tank.
6. Attach the fuel hose to the fuel tank.
7. Put the hose clip in position against the fuel tank.

To adjust the clutch wire (LC 247S, LC 253S)

If the drive starts to feel slow, it is necessary to adjust the clutch wire.

1. To increase the drive speed, turn the adjuster screw counterclockwise.

Note: If the drive is engaged when you do not pull the drive bail, it is necessary to extend the wire.

2. To extend the wire and decrease the drive speed, turn the adjustment screw clockwise. (Fig. 46)

If the drive feels slow also after the adjustment, let an approved service agent replace the drive belt.

To adjust the clutch wire for the adjustable speed (LC 347V, LC 347VE, LC 353V, LC 353VE)

If the engine is started and the slowest speed cannot be engaged, it is necessary to adjust the speed control.

1. To increase the drive speed, turn the adjuster screw counterclockwise.

Note: If the drive is engaged when you do not operate the speed control, it is necessary to extend the wire.

2. To extend the wire and decrease the drive speed, turn the adjustment screw clockwise. (Fig. 46)

If the drive feels slow also after the adjustment, let an approved service agent replace the drive belt.

Engine troubleshooting

Problem	Possible cause	Solution
The engine does not start.	The ignition cable is not connected correctly.	Connect the ignition cable to the spark plug.
	The fuel tank is empty.	Fill the fuel tank with correct fuel type.
	The fuel is old.	Drain the fuel tank and the carburetor. Refuel with new gasoline.
	There is dirt in the carburetor or fuel line.	Clean the carburetor and/or fuel line.
	The spark plug is damaged.	Adjust the electrode gap, clean or replace the spark plug.
	There is fuel on the spark plug.	Clean the spark plug.
The engine does not stop.	The stop mechanism does not operate correctly.	Disconnect the ignition cable from the spark plug. Let an approved service agent repair the product.
The engine does not operate smoothly.	The ignition cable is not connected correctly.	Connect the ignition cable to the spark plug.
	There is dirt in the fuel line or the fuel has expired.	Clean the fuel line. Fill the fuel tank with new fuel of the correct type.
	There is blockage in the fuel tank cap.	Clean the fuel tank cap.
	There is water or dirt in the fuel system.	Drain the fuel tank. Fill the fuel tank with new fuel of the correct type.
	The air filter is dirty.	Clean the air filter.
	The carburetor must be adjusted.	Let a servicing dealer adjust the carburetor.
The engine becomes too hot.	The engine oil level is too low.	Fill engine oil.
	The air flow is not sufficient.	Clean the air filter and the air filter housing.
	The carburetor must be adjusted.	Let a servicing dealer adjust the carburetor.
There is misfire in the engine when it operates at high speed.	The electrode gap in the spark plug is too small.	Adjust the electrode gap.
Unusual noises from the engine during normal load.	Incorrect type of gasoline.	Drain the fuel tank and the carburetor. Refuel with new gasoline. Refer to <i>To examine the fuel system on page 16</i> . If the problem continues speak to your local service dealer.
The engine does not operate smoothly at idle speed.	The spark plug is dirty,damaged or the electrode gap is too wide.	Adjust the electrode gap or replace the spark plug.
	The carburetor must be adjusted.	Adjust the carburetor.
	The air filter is dirty.	Clean the air filter.

Transportation, storage and disposal

Transportation and storage

- For storage and transportation of the product and fuel, make sure that there are no leaks or fumes. Sparks or open flames, for example from electrical devices or boilers, can start a fire.
- Always use approved containers for storage and transportation of fuel.
- Empty the fuel tank before you put the product in storage for a long period of time. Discard the fuel at an applicable disposal location
- Safely attach the product during transportation to prevent damage and accidents.
- Keep the product in a locked area to prevent access for children or persons that are not approved.
- Keep the product in a dry and frost free area.

Transportation and storage for battery and charger

- Do not remove the battery until the product is stationary and cool. To remove the battery, press and hold the button on the top of the battery and remove it from its slot.
- If the time of storage is more than 30 days, charge the battery until it has more than 3 green lights.
- Charge the battery one time each 3 months to prevent damage to the battery.

- The battery and battery charger must be kept in storage between 5 °C and 40 °C. Higher temperatures or high temperature sources, such as fire, can cause damage to the battery.
- Do not disassemble the battery.
- Do not put the battery fully into water. Keep the battery in a cool and dry environment with good airflow.
- If the battery smells, is hot or if the heat causes deformation to the battery during operation, storage or charging, remove the battery and do not use it.
- Make sure that the battery or battery charger are attached during transportation to prevent damage.
- Make sure that the battery charger does not become too hot.

Disposal

- Obey the local recycling requirements and applicable regulations.
- Discard all chemicals, such as engine oil or antifreeze, at a service center or at an applicable disposal location.
- When the product is no longer in use, send it to a Husqvarna dealer or discard it at a recycling location.
- Discard the battery at a service center or discard it at a disposal location for used batteries.

Technical data

	LC 247	LC 247S	LC 253S
Engine			
Brand	Husqvarna	Husqvarna	Husqvarna
Model	HS 139A	HS 139A	HS 166A
Engine type	Single cylinder, 4-stroke, forced Air cooling, OHV	Single cylinder, 4-stroke, forced Air cooling, OHV	Single cylinder, 4-stroke, forced Air cooling, OHV
Displacement, cm ³	139	139	166
Engine speed - Nominal, rpm	2900/min	2900/min	2900/min
Nominal engine output, kW ³	2.2	2.2	2.75
Ignition system			

³ The power rating of the engine indicated is the average net output (at specified rpm) of a typical production engine for the engine model measured to SAE standard J1349/ISO1585. Mass production engines may differ from this value. Actual power output for the engine installed on the final product will depend on the operating speed, environmental conditions and other values.

	LC 247	LC 247S	LC 253S
Spark plug	Husqvarna HQT-7	Husqvarna HQT-7	Husqvarna HQT-7
Electrode gap, mm	0.7-0.8	0.7-0.8	0.7-0.8
Fuel and lubrication system			
Engine lubrication type	Splash	Splash	Splash
Fuel tank capacity, l	0.9	0.9	1
Oil tank capacity, l	0.5	0.5	0.5
Engine oil ⁴	Husqvarna SAE 30, Husqvarna SAE 5W-30 Synthetic, Husqvarna SAE 10W-40	Husqvarna SAE 30, Husqvarna SAE 5W-30 Synthetic, Husqvarna SAE 10W-40	Husqvarna SAE 30, Husqvarna SAE 5W-30 Synthetic, Husqvarna SAE 10W-40
Weight			
With empty tanks, kg	27.5	29.5	31.5
Noise emissions ⁵			
Sound power level, measured dB (A)	95	95	97
Sound power level, guaranteed L _{WA} dB (A)	96	96	98
Sound levels ⁶			
Sound pressure level at the operator's ear, dB (A)	84	84	87
Vibration levels ⁷			
Vibrations upper handle, m/s ²	2.7	2.7	3.9
Cutting equipment			
Cutting height, mm	20–75	20–75	20–75
Cutting width, mm	470	470	530
Cutting system	Collection / BioClip® / Rear discharge	Collection / BioClip® / Rear discharge	Collection / BioClip® / Rear discharge
Blade - Standard	Collection 5882755-10	Collection 5882755-10	Collection 5797972-10
Blade - Accessory	Mulch 5882757-10	Mulch 5882757-10	Mulch 5889039-10
Grass catcher capacity, l	55	55	60
Drive			
Self walk speed, km/h	–	4	4

⁴ Use engine oil of quality API SJ or higher. If SAE-30 oil is used at temperature lower than +5 °C, there is a risk that it does not lubricate the engine sufficiently. This can cause engine damage. Refer to *To replace the engine oil on page 15* for the correct oil for low temperatures. Refer to the viscosity chart in the engine manual (if included) and select the best viscosity based on the expected outside temperature.

⁵ Noise emissions in the environment measured as sound power (L_{WA}) in conformity with EC directive 2000/14/EC.

⁶ Reported data for noise pressure level has a typical statistical dispersion (standard deviation) of 1.2 dB (A).

⁷ Reported data for vibration level has a typical statistical dispersion (standard deviation) of 0.2 m/s².

	LC 247	LC 247S	LC 253S
Start system			
Electric starter	No	No	No
Battery	-	-	-

	LC 347V	LC 347VE	LC 353V	LC 353VE
Engine				
Brand	Husqvarna	Husqvarna	Husqvarna	Husqvarna
Model	HS 166A	HS 166AE	HS 166A	HS 166AE
Engine type	Single cylinder, 4-stroke, forced Air Cooling, OHV	Single cylinder, 4-stroke, forced Air Cooling, OHV	Single cylinder, 4-stroke, forced Air Cooling, OHV	Single cylinder, 4-stroke, forced Air Cooling, OHV
Displacement, cm ³	166	166	166	166
Engine speed - Nominal, rpm	2900/min	2900/min	2900/min	2900/min
Nominal engine output, kW ⁸	2.75	2.75	2.75	2.75
Ignition system				
Spark plug	Husqvarna HQT-7	Husqvarna HQT-7	Husqvarna HQT-7	Husqvarna HQT-7
Electrode gap, mm	0.7-0.8	0.7-0.8	0.7-0.8	0.7-0.8
Fuel and lubrication system				
Engine lubrication type	Splash	Splash	Splash	Splash
Fuel tank capacity, l	1.0	0.9	1.0	0.9
Oil tank capacity, l	0.5	0.5	0.5	0.5
Engine oil ⁹	Husqvarna SAE 30, Husqvarna SAE 5W-30 Synthetic, Husqvarna SAE 10W-40	Husqvarna SAE 30, Husqvarna SAE 5W-30 Synthetic, Husqvarna SAE 10W-40	Husqvarna SAE 30, Husqvarna SAE 5W-30 Synthetic, Husqvarna SAE 10W-40	Husqvarna SAE 30, Husqvarna SAE 5W-30 Synthetic, Husqvarna SAE 10W-40
Weight				
With empty tanks, kg	30.5	31.5	32.0	33.0

⁸ The power rating of the engine indicated is the average net output (at specified rpm) of a typical production engine for the engine model measured to SAE standard J1349/ISO1585. Mass production engines may differ from this value. Actual power output for the engine installed on the final product will depend on the operating speed, environmental conditions and other values.

⁹ Use engine oil of quality SF, SG, SH, SJ or higher. If SAE-30 oil is used at temperature lower than +5 °C, there is a risk that it does not lubricate the engine sufficiently. This can cause engine damage. Refer to *To replace the engine oil on page 15* for the correct oil for low temperatures. See the viscosity chart in the engine manual (if included) and select the best viscosity based on the expected outside temperature.

	LC 347V	LC 347VE	LC 353V	LC 353VE
Noise emissions ¹⁰				
Sound power level, measured dB (A)	95	95	97	97
Sound power level, guaranteed L _{WA} dB (A)	96	96	98	98
Sound levels ¹¹				
Sound pressure level at the operator's ear, dB (A)	86	86	87	87
Vibration levels ¹²				
Vibrations upper handle, m/s ²	3.5	3.5	3.9	3.9
Cutting equipment				
Cutting height, mm	20–75	20–75	20–75	20–75
Cutting width, mm	470	470	530	530
Cutting system	Collection / Bio-Clip® / Rear discharge	Collection / Bio-Clip® / Rear discharge	Collection / Bio-Clip® / Rear discharge	Collection / Bio-Clip® / Rear discharge
Blade - Standard	Collection 5882755-10	Collection 5882755-10	Collection 5797972-10	Collection 5797972-10
Blade - Accessory	Mulch 5882757-10	Mulch 5882757-10	Mulch 5889039-10	Mulch 5889039-10
Grass catcher capacity, l	55	55	60	60
Drive				
Self walk speed, km/h	2.8–5.0	2.8–5.0	2.8–5.0	2.8–5.0
Start system				
Electric starter	No	Yes	No	Yes
Battery	-	Li-ion, 10.8V, 21.6Wh	-	Li-ion, 10.8V, 21.6Wh

¹⁰ Noise emissions in the environment measured as sound power (L_{WA}) in conformity with EC directive 2000/14/EC.

¹¹ Reported data for noise pressure level has a typical statistical dispersion (standard deviation) of 1.2 dB (A).

¹² Reported data for vibration level has a typical statistical dispersion (standard deviation) of 0.2 m/s².

Declaration of Conformity

EU Declaration of Conformity

We, **Husqvarna AB**, SE-561 82 Huskvarna, Sweden, tel: +46-36-146500, declare on our sole responsibility that the product:

Description	Lawn Mower
Brand	Husqvarna
Type / Model	LC 247, LC 247S, LC 253S, LC 347V, LC 347VE, LC 353V, LC 353VE
Identification	Serial numbers dating from 2022 and onwards

complies fully with the following EU directives and regulations:

Regulation	Description
2006/42/EC	"relating to machinery"
2014/30/EU	"relating to electromagnetic compatibility"
2000/14/EC	"relating to the noise emissions in the environment"
2011/65/EU	"on the restriction of the use of certain hazardous substances in electrical and electronic equipment"

and that the following standards and/or technical specifications are applied:
EN ISO 5395-1:2013+A1:2018, EN ISO 5395-2:2013+A1:2016+A2:2017, EN ISO 12100:2010, EN ISO 14982:2009, EN IEC 63000:2018

Notified Body: 0404, RISE SMP Svensk Maskinprovning AB, Box 4053, SE-904 03 Umeå, Sweden has certified conformity with the council's directive 2000/14/EC, conformity assessment procedure: Annex VI.

For information relating to noise emissions, refer to *Technical data on page 18*.

Huskvarna, 2022-10-03

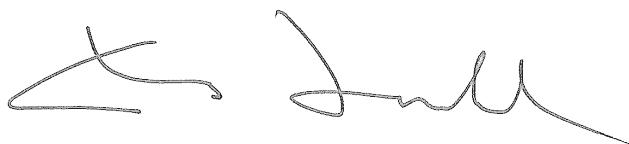

Claes Losdal, Development Manager/Garden Products
Husqvarna AB

Responsible for technical documentation



UK Declaration of Conformity

We, **Husqvarna AB**, SE-561 82 Huskvarna, Sweden, tel: +46-36-146500, declare on our sole responsibility that the product:

Description	Lawn Mower
Brand	Husqvarna
Type / Model	LC 247, LC 247S, LC 253S, LC 347V, LC 353V
Identification	Serial numbers dating from 2022 and onwards

complies fully with the following UK regulations:

Description
The Restriction of the Use of Certain Hazardous Substances in Electrical and Electronic Equipment Regulations 2012
The Supply of Machinery (Safety) Regulations 2008
Electromagnetic Compatibility Regulations 2016
The Noise Emission in the Environment by Equipment for use Outdoors Regulations 2001, schedule 9

and that the following standards and/or technical specifications are applied:
EN ISO 5395-1:2013+A1:2018, EN ISO 5395-2:2013+A1:2016+A2:2017, EN ISO 12100:2010, EN ISO 14982:2009, EN IEC 63000:2018

UK Importer:
Husqvarna UK Ltd
Preston Road, Co. Durham
DL5 6UP

Approved Body: 0888, HORIBA MIRA Certification Ltd. Watling Street, Nuneaton, Warwickshire, CV10 0TU, UK, has carried out certified conformity according to the Outdoor Noise Regulations of 2001, conformity assessment procedure: Schedule 9.

For information relating to noise emissions, refer to *Technical data on page 18*.

Huskvarna, 2022-10-31

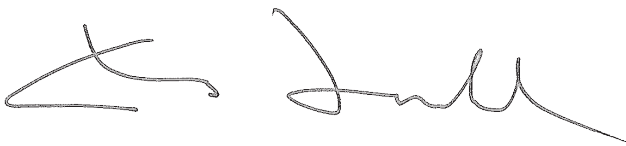

Claes Losdal, Development Manager/Garden Products
Husqvarna AB

Responsible for technical documentation

