

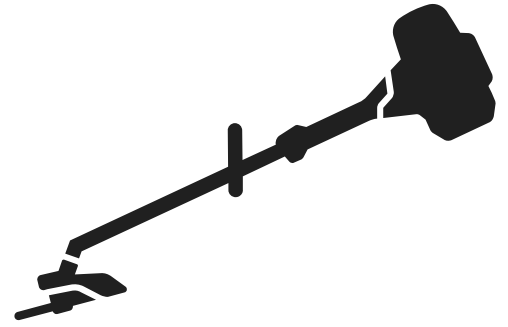

Husqvarna®



525LK

EN	Operator's manual	2-24
DE	Bedienungsanweisung	25-48
ES	Manual de usuario	49-72
FR	Manuel d'utilisation	73-96
IT	Manuale dell'operatore	97-119
NL	Gebruiksaanwijzing	120-143

Contents

Introduction.....	2	Troubleshooting.....	19
Safety.....	4	Transportation and storage.....	20
Assembly.....	10	Technical data.....	20
Operation.....	12	Accessories.....	21
Maintenance.....	16	Declaration of Conformity.....	23

Introduction

Product description

The product is a grass trimmer with a combustion engine.

Work is constantly in progress to increase your safety and efficiency during operation. Speak to your servicing dealer for more information.

Intended use

The product is used with non-metallic trimmer lines, non-metallic strings or equivalent non-metallic flexible cutting

elements. Do not use the product for other tasks than to cut weed, grass or similar soft vegetation.

Note: National regulations can set limit to the operation of the product.

Product overview

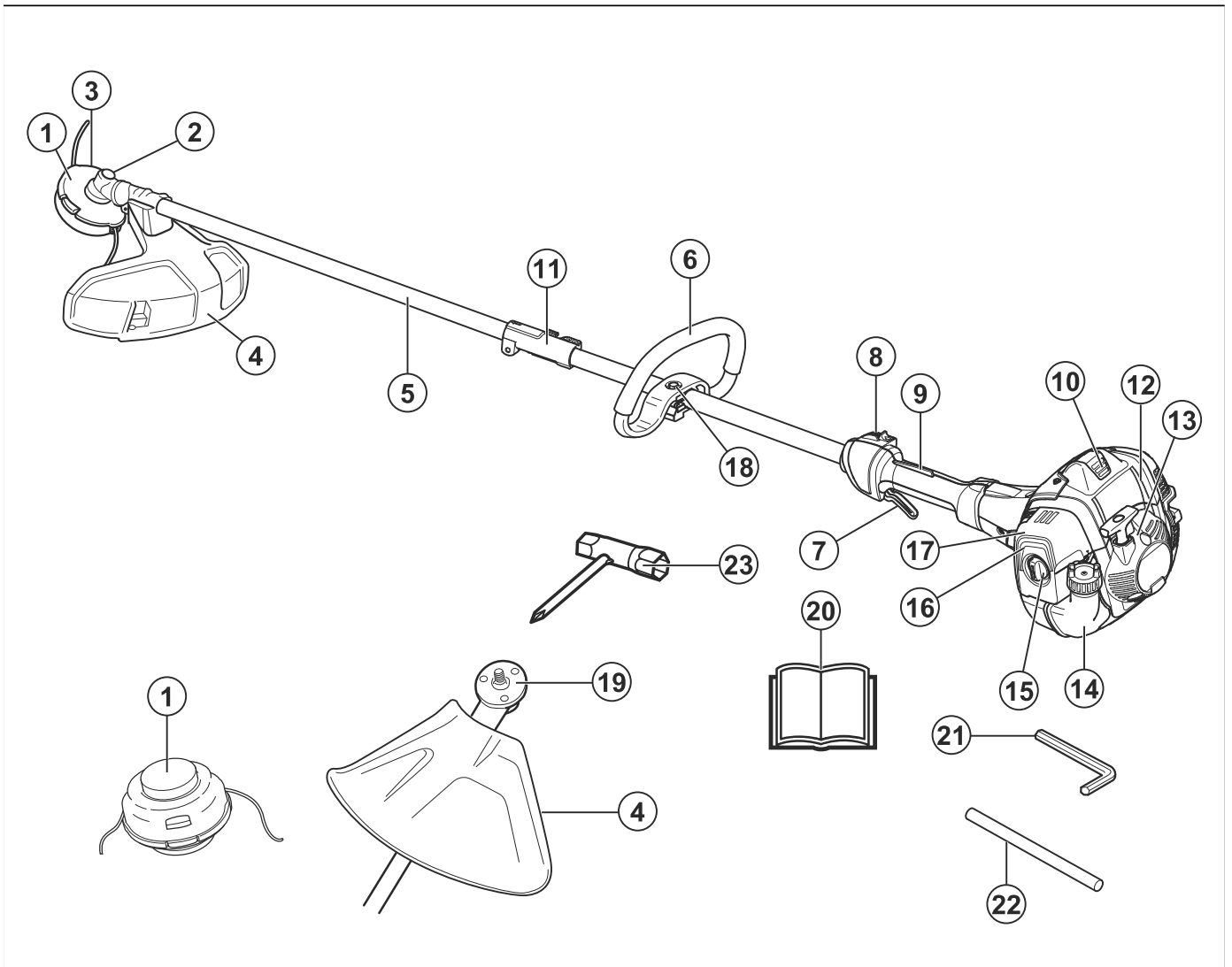

1. Trimmer head
2. Grease filler cap
3. Bevel gear
4. Cutting attachment guard
5. Shaft
6. Loop handle
7. Throttle trigger
8. Stop switch
9. Throttle trigger lockout
10. Spark plug cap and spark plug
11. Shaft coupling
12. Cylinder cover
13. Starter rope handle
14. Fuel tank
15. Air filter cover
16. Air purge bulb
17. Choke control
18. Handle adjustment
19. Drive disc
20. Operator's manual

21. Hex key
22. Locking pin
23. Combination wrench

Symbols on the product



WARNING! Be careful and use the product correctly. This product can cause serious injury or death to the operator or others.



Read the operator's manual carefully and make sure that you understand the instructions before you use this product.



Use a protective helmet in locations where objects can fall on you. Use approved hearing protection. Use approved eye protection.



Use approved protective gloves.



Use heavy-duty slip-resistant boots.



The product can cause objects to eject, which can cause injury.



Maximum speed of the output shaft.



Keep a minimum of 15 m distance to persons and animals during operation of the product.



Only use flexible cutting wire. Do not use metal cutting equipment for grass trimming.

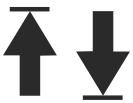

The arrows show the limit for the handle position.

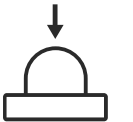

Air purge bulb.

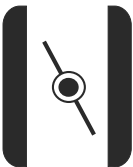

Choke.



Fuel.



Noise emission to the environment label as per EU and UK directives and regulations, and New South Wales legislation "Protection of the Environment Operations (Noise Control) Regulation 2017". The guaranteed sound power level of the product is specified in *Technical data on page 20* and on the label.



The product agrees with the applicable EC directives.



This product conforms to applicable UK regulations.

yyyywwxxxx

The rating plate shows the serial number. **yyyy** is the production year, **ww** is the production week.

Note: Other symbols/decals on the product refer to certification requirements for some markets.

Euro V Emissions



WARNING: Tampering with the engine voids the EU type-approval of this product.

Product damage

We are not responsible for damages to our product if:

- the product is incorrectly repaired.
- the product is repaired with parts that are not from the manufacturer or not approved by the manufacturer.
- the product has an accessory that is not from the manufacturer or not approved by the manufacturer.
- the product is not repaired at an approved service center or by an approved authority.

Safety

Safety definitions

Warnings, cautions and notes are used to point out specially important parts of the manual.



WARNING: Used if there is a risk of injury or death for the operator or bystanders if the instructions in the manual are not obeyed.



CAUTION: Used if there is a risk of damage to the product, other materials or the adjacent area if the instructions in the manual are not obeyed.

Note: Used to give more information that is necessary in a given situation.

General safety instructions



WARNING: Read the warning instructions that follow before you use the product.

- A clearing saw, brushcutter or trimmer can be dangerous if used carelessly or incorrectly and can cause serious injury or death to the operator or others. It is extremely important that you read and understand the contents of this operator's manual.
- Under no circumstances may the design of the product be modified without the permission of the manufacturer. Never use a product that has been modified in any way from its original specification and always use original accessories. Non-authorized modifications and/or accessories can result in serious personal injury or the death of the operator or others.
- The inside of the muffler contain chemicals that may be carcinogenic. Avoid contact with these elements in the event of a damaged muffler.
- This product produces an electromagnetic field during operation. This field may under some circumstances interfere with active or passive medical implants. To reduce the risk of serious or fatal injury, we recommend persons with medical implants to consult their physician and the medical implant manufacturer before operating this product.

Safety instructions for operation



WARNING: Read the warning instructions that follow before you use the product.

- You must understand the difference between grass clearing and grass trimming before use.
- If you encounter a situation where you are uncertain how to proceed you should ask an expert. Contact your dealer or your service workshop. Avoid all usage which you consider to be beyond your capability.
- Never use a product that is faulty. Carry out the safety checks, maintenance and service instructions described in this manual. Some maintenance and service measures must be carried out by trained and qualified specialists. Refer to *Maintenance on page 16*.
- All covers, guards and handles must be fitted before you start the product. Ensure that the spark plug cap and ignition lead are undamaged to avoid the risk of electric shock.
- Never use the product if you are fatigued, while under the influence of alcohol or drugs, medication or anything that could affect your vision, alertness, coordination or judgement.
- Do not use the product in bad weather such as dense fog, heavy rain, strong wind, intense

cold, etcetera. Working in bad weather is tiring and often brings added risks, such as icy ground, unpredictable felling direction, etcetera.

- The only accessories you can operate with this engine unit are the cutting attachments that we recommend. Refer to *Accessories on page 21*.
- Never allow children to use or be in the vicinity of the product. As the product is equipped with a spring-loaded start/stop switch and can be started by low speed and force on the starter handle, even small children under some circumstances can produce the force necessary to start the product. This can mean a risk of serious personal injury. Therefore remove the spark plug cap when the product is not under close supervision.
- Running an engine in a confined or badly ventilated area can result in death due to asphyxiation or carbon monoxide poisoning.
- The complete clutch cover and shaft must be fitted before the product is started, otherwise the clutch can come loose and cause personal injury.
- Ensure that no people or animals come closer than 15 m while you work. When several operators are working in the same area the safety distance should be at least 15 m. Otherwise there is a risk of serious personal injury. Stop the product immediately if anyone approaches. Never swing the product around without first checking behind you to make sure that no one is within the safety zone.
- Ensure that people, animals or other things can not affect your control of the product or that they do not come in contact with the cutting attachment or loose objects that are thrown out by the cutting attachment. However, do not use the product unless you are able to call for help in the event of an accident.
- Always inspect the working area. Remove all loose objects such as stones, broken glass, nails, steel wire, string, etcetera, that could be thrown out or become wrapped around the cutting attachment.
- Make sure that you can move and stand safely. Check the area around you for possible obstacles (roots, rocks, branches, ditches, etcetera) in case you have to move suddenly. Take great care when you work on sloping ground.



- Keep a good balance and a firm foothold at all times. Do not overreach.
- Always hold the product with both hands. Hold the product on the right side of your body.
- Keep the cutting attachment below waist level.
- Switch off the engine before you move to another area. Fit the transportation guard before you carry or transport the equipment any distance.
- Never put the product down with the engine running unless you have it in clear sight.
- Stop the engine and cutting equipment before you remove material that has wound around the blade shaft. Neither the operator of the product nor anyone else may attempt to remove the cut material while the engine is running or the cutting equipment is rotating, as this can result in serious injury. The bevel gear can get hot during use and may remain so for a while afterwards. You could get burnt if you touch it.
- Watch out for thrown objects. Always wear approved eye protection. Never lean over the cutting attachment guard. Stones, rubbish, etcetera, can be thrown up into the eyes which can cause blindness or serious injury.
- Sometimes branches or grass get caught between the guard and cutting attachment. Always stop the engine before you clean the product.
- Always slow the engine to idle speed after each working operation. Long periods at full throttle without any load on the engine can lead to serious engine damage.
- Listen out for warning signals or shouts when you wear hearing protection. Always remove your hearing protection as soon as the engine stops.
- Overexposure to vibration can lead to circulatory damage or nerve damage in people who have impaired circulation. Contact your doctor if you experience symptoms of overexposure to vibration. These symptoms include numbness, loss of feeling, tingling, pricking, pain, loss of strength, changes in skin color or condition. These symptoms normally appear in the fingers, hands or wrists.
- Do not use a product with a damaged spark plug cap.
- Do not use a product with a damaged muffler.
- Keep all parts of your body away from the rotating cutting attachment and hot surfaces.
- Never use a product with a faulty muffler
- Never start or use the product indoors, near combustible material or in spaces that lacks proper ventilation. The exhaust fumes from the engine contain carbon monoxide, an odorless, poisonous and highly dangerous gas. Also, the exhaust fumes are hot and may contain sparks that can start a fire.

Personal protective equipment



WARNING: Read the warning instructions that follow before you use the product.

- Always use approved personal protective equipment when you use the product. Personal protective equipment cannot fully prevent injury but it decreases the degree of injury if an accident does occur. Let your dealer help you select the right equipment.
- Use a protective helmet where there is a risk of falling objects.

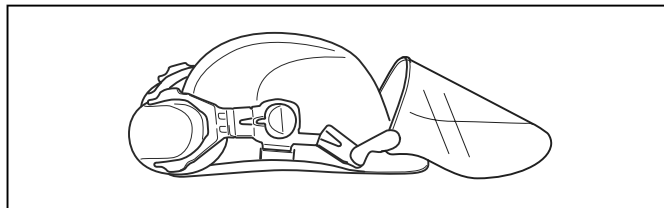

- Use approved hearing protection that provides adequate noise reduction. Long-term exposure to noise can result in permanent hearing impairment.

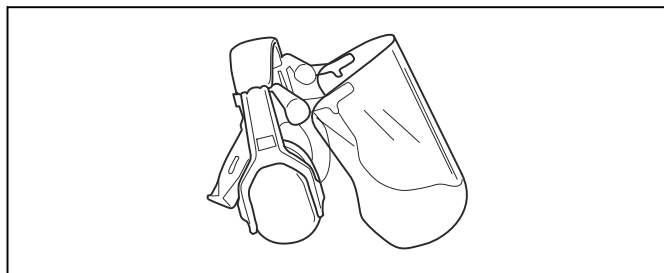

- Use approved eye protection. If you use a visor, you must also use approved protective goggles. Approved protective goggles must comply with the ANSI Z87.1 standard in the USAs or EN 166 in EU countries.

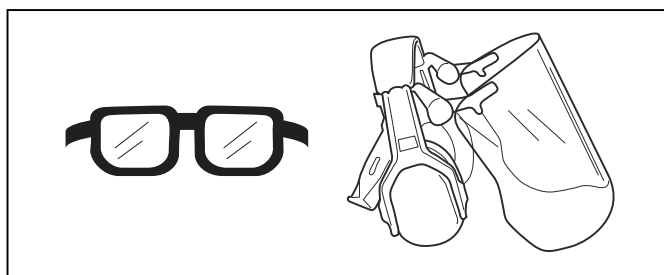

- Use gloves when necessary, for example when you attach, examine or clean the cutting equipment.

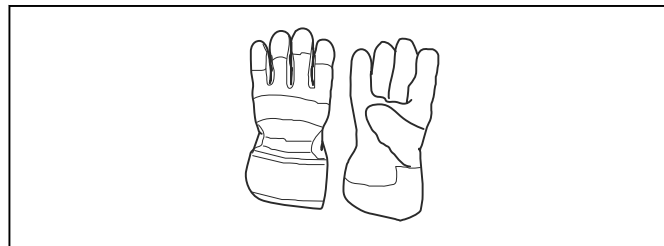

- Use protective boots with steel toes and non-slip soles.



- Use clothing made of a strong fabric. Always use heavy, long pants and long sleeves. Do not use loose clothing that can catch on twigs and branches. Do not wear jewelry, short pants, sandals or go with bare feet. Put your hair up safely above shoulder level.
- Keep first aid equipment close at hand.

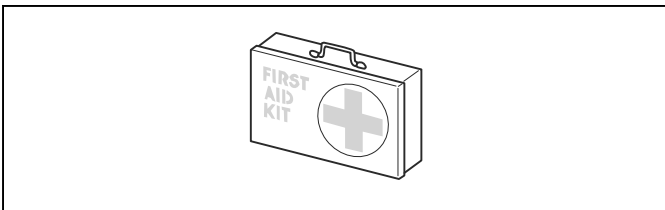

Safety devices on the product



WARNING: Read the warning instructions that follow before you use the product.

In this section the product's safety features, its purpose and how checks and maintenance should be carried out to ensure that it operates correctly. See instructions under the heading *Product overview on page 3* to find where these parts are located on your product.

The life span of the product can be reduced and the risk of accidents can increase if product maintenance is not carried out correctly and if service and/or repairs are not carried out professionally. If you need further information please contact your nearest servicing dealer.



WARNING: Never use a product with damaged safety components. The product's safety equipment must be inspected and maintained as described in this section. If your product fails any of these checks, contact your service agent to get it repaired.



CAUTION: All servicing and repair work on the machine requires special training. This is especially true of the machine's safety equipment. If your machine fails any of the checks described below you must contact your service agent. When you buy any of our products we guarantee the availability of professional repairs and service. If the retailer who sells your

machine is not a servicing dealer, ask him for the address of your nearest service agent.

To do a check of the throttle lockout

The throttle lockout is designed to prevent accidental operation of the throttle control.

1. Press the throttle trigger lockout (A) and make sure that the throttle control is released (B). When you release the handle the throttle control and the throttle trigger lockout both move back to their initial positions. This movement is controlled by two independent return springs. This arrangement means that the throttle control is automatically locked at the idle setting.

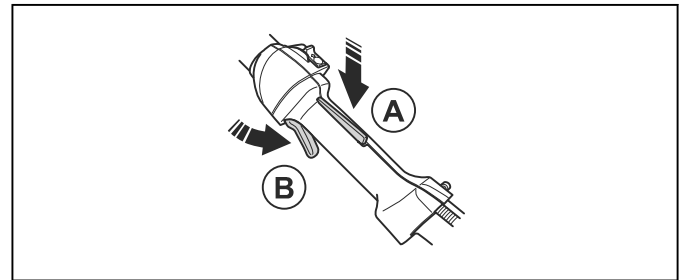

2. Make sure that the throttle control is locked at the idle setting when the throttle trigger lockout is released.

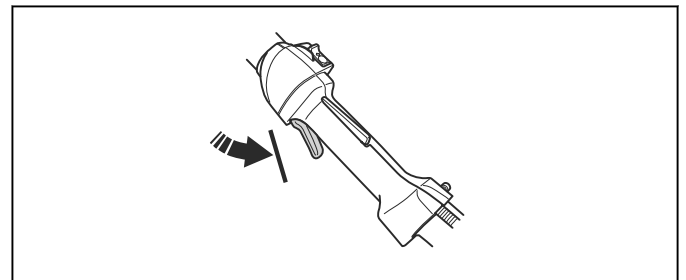

3. Press the throttle trigger lockout and make sure that it returns to its initial position when you release it.

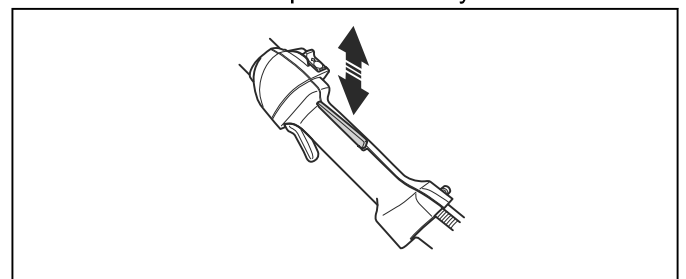

4. Do a check of the throttle control and throttle trigger lockout move freely and that the return springs work properly.

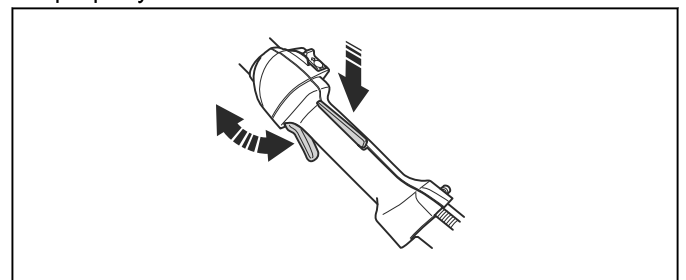

5. Start the product (refer to the instructions under *To start the product on page 14*) and apply full throttle.
6. Release the throttle and make sure that the cutting attachment stops and remains at a standstill. If the cutting attachment rotates with the throttle in the idle position the carburettor idle setting must be checked. See instructions under the chapter *Maintenance on page 16*.

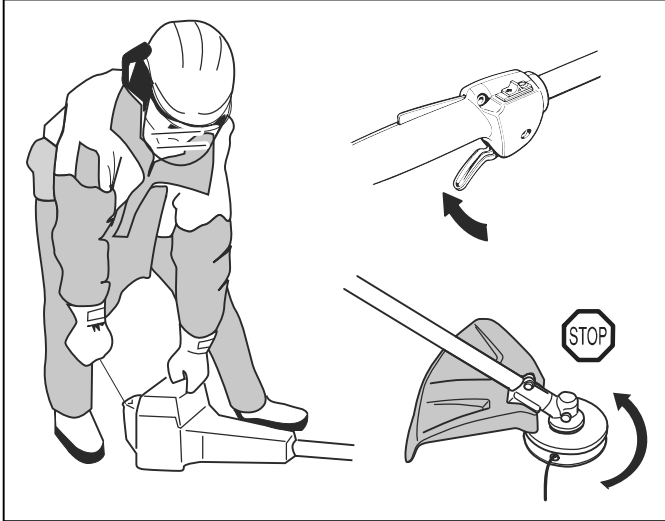

To do a check of the stop switch

1. Start the engine.
2. Move the stop switch to the stop position and make sure that the engine stops.

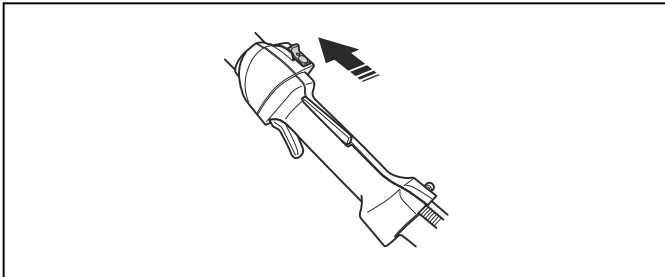

To do a check of the cutting attachment guard



WARNING: Do not use a cutting attachment without an approved and correctly attached cutting attachment guard. Refer to, *Accessories on page 21*.



WARNING: Always use the recommended cutting attachment guard for the cutting attachment that you use. If an incorrect or faulty cutting attachment guard is fitted this can cause serious personal injury. Refer to, *Technical data on page 20*.

The cutting attachment guard prevents injuries from objects that eject in the direction of the operator. It also prevents injuries that occur if you touch the cutting attachment.

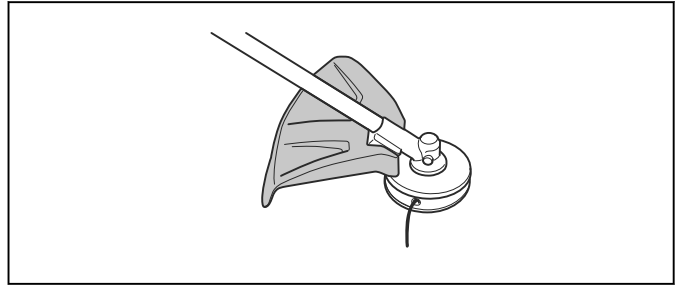

1. Do a visual check for damages, for example cracks.
2. Replace the cutting attachment guard if it is damaged.

To do a check of the vibration damping system



WARNING: Use of incorrectly wound cord or an incorrect cutting attachment increases the level of vibration.

The vibration damping system decreases vibration in the handles to a minimum which makes the operation easier. The vibration damping system decreases the vibrations between the engine unit and the shaft unit.

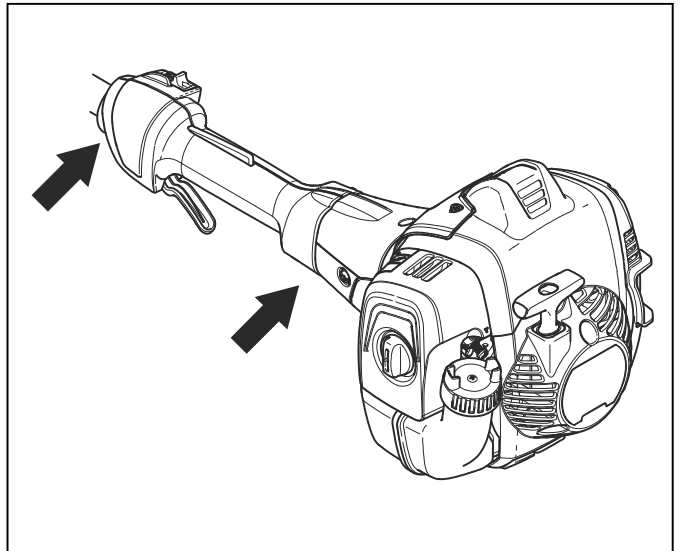

1. Stop the engine.
2. Do a visual check for deformation and damage, for example cracks.
3. Make sure that the vibration damping units are attached correctly.

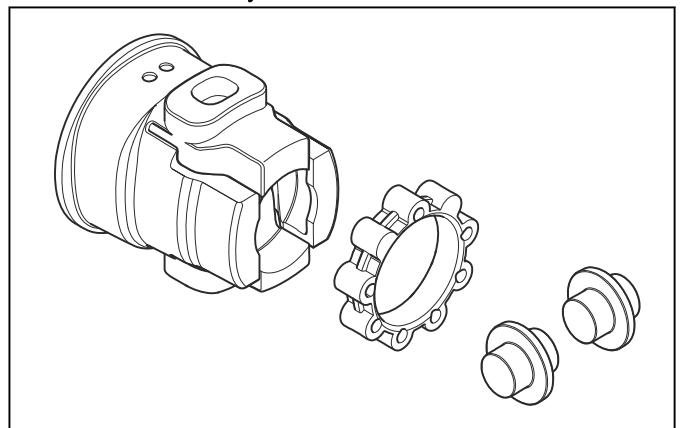

To do a check of the muffler

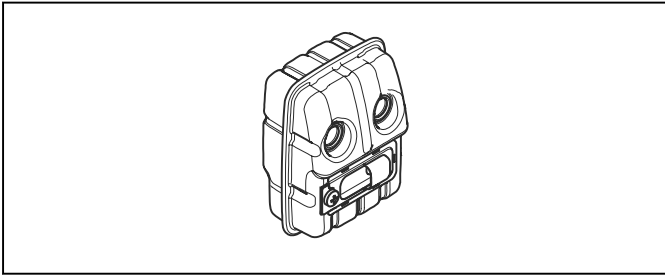

The muffler keeps noise levels to a minimum and sends exhaust fumes away from the operator.

- Do a visual check for damage and deformation.
- Make sure that the muffler is correctly attached to the product.

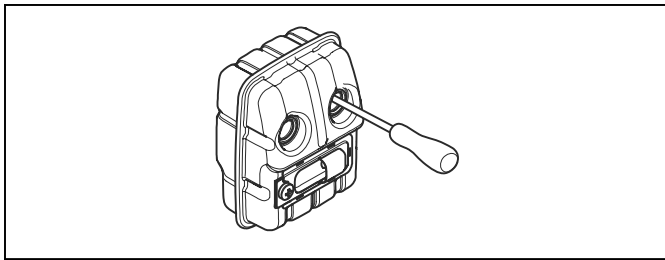

- If the muffler on your product has a spark arrester screen, do a visual check. Replace the spark arrester screen if it is damaged.
 - a) Clean the spark arrester screen if it is blocked. A blocked spark arrester screen causes the engine to become too hot which causes damage to the engine.
 - b) Make sure that the spark arrester mesh is attached correctly.

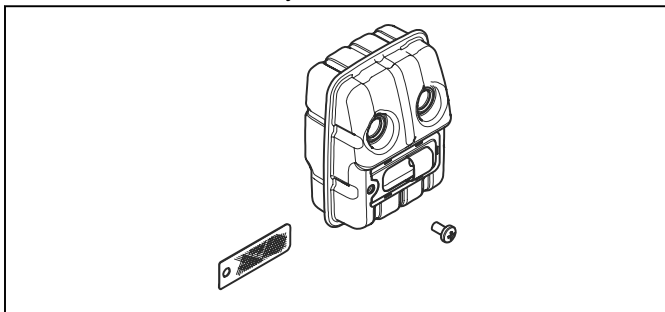

Fuel Safety



WARNING: Read the warning instructions that follow before you use the product.

- Never start the product if you spill fuel on it. Wipe the spillage off and allow remaining fuel to evaporate.
- Never start the product if you spill fuel on yourself or your clothes. Change your clothes and wash any

part of your body that has come in contact with fuel. Use soap and water.

- Never start the product if the product is leaking fuel. Check regularly for leaks from the fuel cap and fuel lines.
- Always put the product on a flat surface and make sure the cutting attachment cannot come in contact with any object while you add fuel.
- Take care when handling fuel. Bear in mind the risk of fire, explosion and inhaling fumes.
- Observe caution when handling fuel and make sure there is adequate ventilation. Fuel and fuel fumes are highly inflammable and can cause serious injury when inhaled or allowed to come in contact with the skin.
- Mix and pour fuel outdoors, where there are no sparks or flames.
- Do not smoke or place hot objects near fuel.
- Always stop the engine and let it cool off for a few minutes before you refuel.
- Open the fuel cap slowly so that any excess pressure is released gently when you refuel.
- Tighten the fuel cap carefully after you refueled.
- Clean the area around the fuel cap. Contamination in the tank can cause operating problems.
- Always move the product 3m (10ft) or further from the refuelling area and source before starting.

Safety instructions for maintenance



WARNING: Always stop the engine before you do any work on the cutting attachment. The cutting attachment continues to rotate even after the throttle has been released. Ensure that the cutting attachment has stopped completely and disconnect the spark plug before you start to work on it.



WARNING: A faulty cutting attachment may increase the risk of accidents.



WARNING: Make sure that the trimmer cord is wound tightly and evenly around the drum, otherwise the product will generate harmful vibration.

- Only use cutting attachments with the guards we recommend. Refer to *Accessories on page 21*.

Assembly

Introduction



WARNING: Before you assemble the product, you must read and understand the safety chapter.



WARNING: Remove the spark plug cable from the spark plug before you assemble the product.

To assemble the loop handle

1. Put the loop handle onto the shaft, between the arrows.

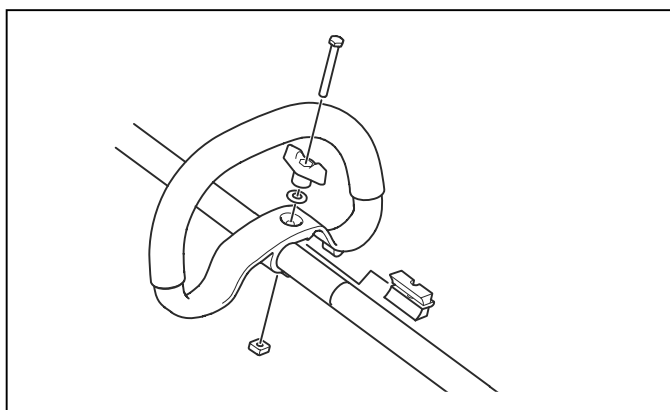

2. Put the spacer into the slot of the loop handle.
3. Install the nut, the knob and the screw. Do not tighten fully.
4. Adjust the product to an applicable operation position.
5. Tighten the knob.

To assemble the two-piece shaft

1. Turn the knob to loosen the coupling.
2. Align the tab of the cutting attachment (A) with the arrow of the coupling (B).

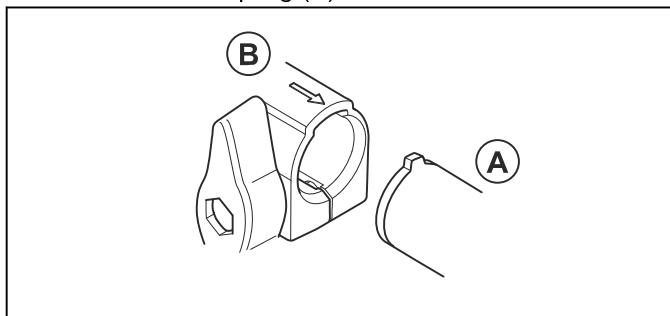

3. Carefully push the shaft into the coupling until you hear a click.

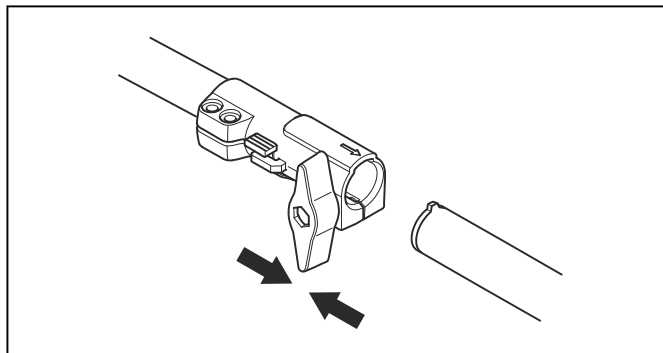

4. Tighten the knob fully.

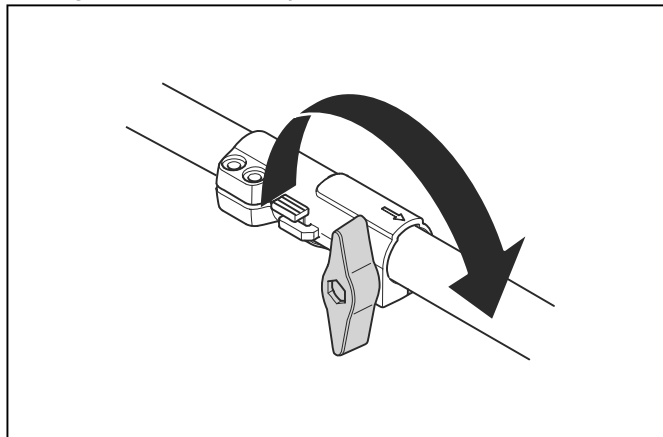

To disassemble the two-piece shaft

1. Turn the knob 3 turns or more to loosen the coupling.

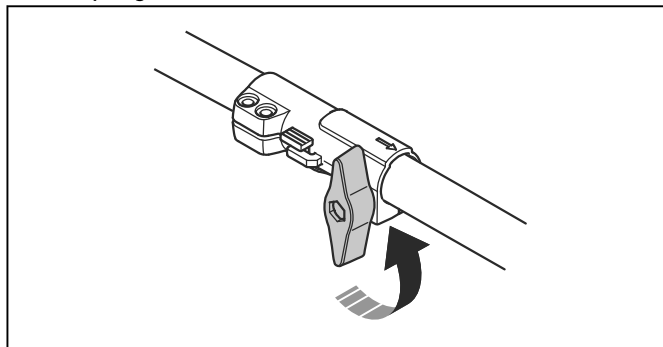

2. Push and hold the button (C).
3. Hold tight to the end of the shaft that the engine is attached to.

4. Pull the attachment straight out of the coupling.

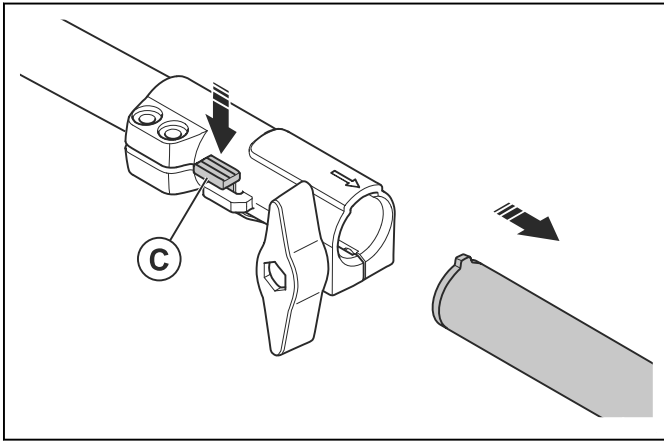

To assemble the cutting attachment guard and trimmer head

1. Attach the correct cutting attachment guard (A) for the trimmer head. Refer to *Accessories on page 21*.
2. Put the cutting attachment guard onto the fitting on the shaft.
3. Attach with the bolt (L).

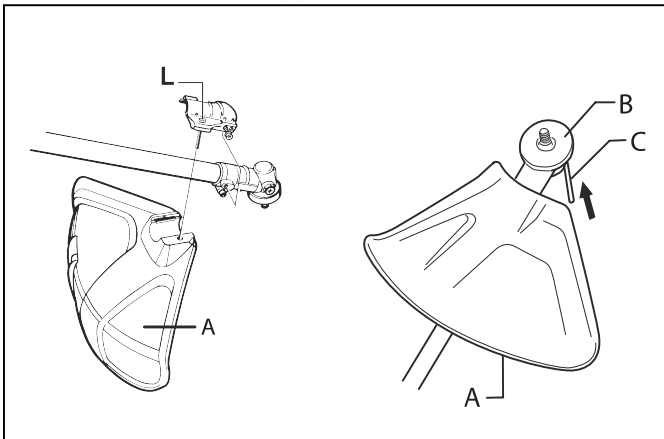

4. Install the drive disc (B) on the output shaft.
5. Turn the output shaft until one of the holes in the drive disc aligns with the related hole in the gear housing.
6. Put the locking pin (C) in the hole to lock the shaft.
7. Turn the trimmer head /plastic blades (H) in the opposite direction from which the trimmer head/ plastic blades rotates.

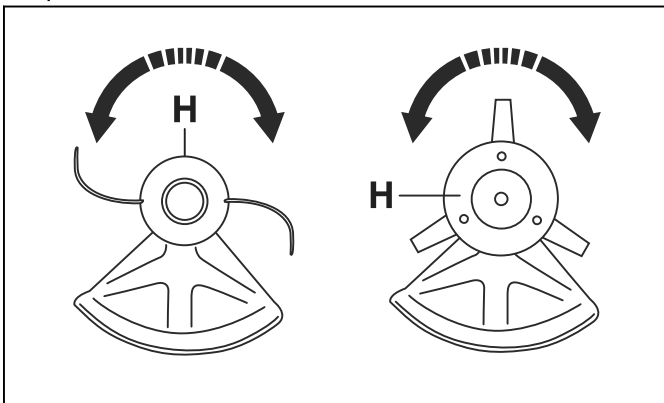

To disassemble the cutting attachment guard and trimmer head

1. Turn the trimmer head /plastic blades (H) in the direction from which the trimmer head/plastic blades rotates.

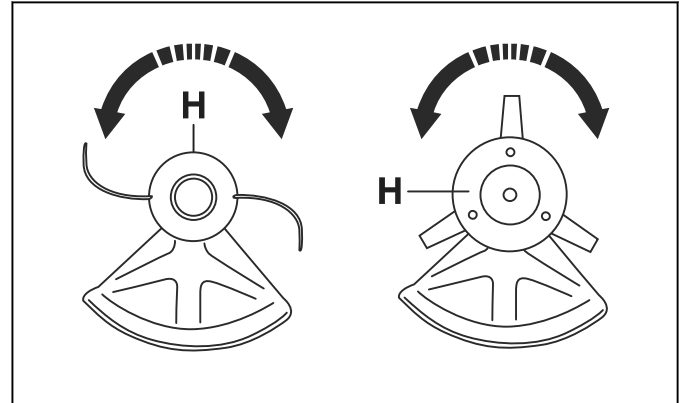

2. Pull the locking pin (C) out from the hole to unlock the shaft.
3. Remove the drive disc (B) on the output shaft.
4. Loosen the bolt (L) from the cutting attachment guard-fitting on the shaft.

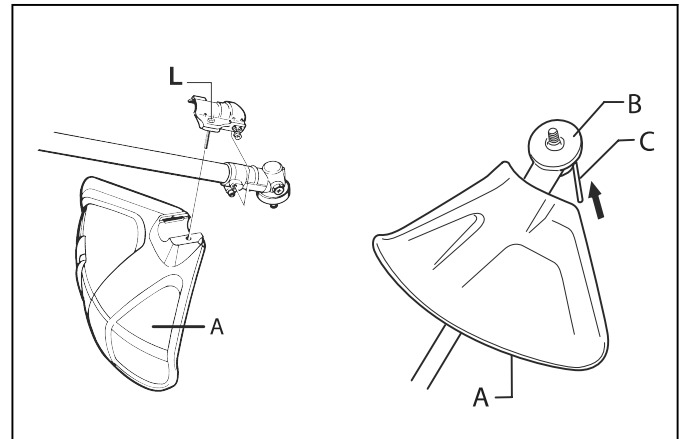

5. Remove the cutting attachment guard (A).

Operation

Fuel

This product has a two-stroke engine.



CAUTION: Incorrect type of fuel can result in engine damage. Use a mixture of gasoline and two-stroke oil.

Gasoline



CAUTION: Always use a quality gasoline/oil mixture of at least 90 octane (RON). There is a risk that use of lower octane grade causes knocking. This gives rise to high engine temperature, which can result in serious engine damage.



CAUTION: If your product is equipped with a catalytic converter use a good quality unleaded gasoline/oil mixture. Leaded gasoline will destroy the catalytic converter.

- Use low-emission gasoline, also known as alkylate gasoline, if it is available.

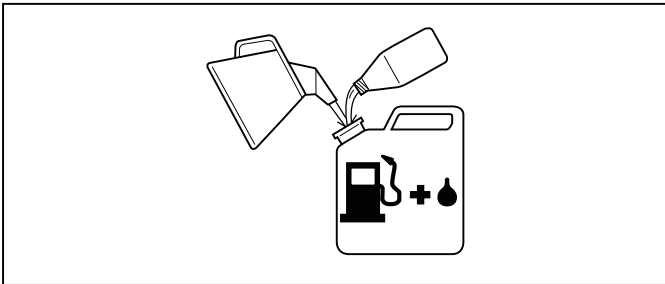

- Ethanol blended fuel, E10 may be used (max 10% ethanol blend). Using ethanol blends higher than E10 will cause lean running condition which can damage the engine.
- We recommend a higher octane rating when you do work at continuous high speed.

Husqvarna alkylate fuel

We recommend you to use Husqvarna alkylate fuel for best performance. The fuel contains less dangerous material compared to regular fuel, which decreases dangerous exhaust fumes. The fuel gives a low quantity of dangerous remainings when it is combusted, which keeps the components of the engine more clean. This extends the life of the engine. Husqvarna alkylate fuel is not available in all markets.

Two-stroke oil



CAUTION: Unsatisfactory oil quality and/or incorrect oil/fuel ratio can damage the product and decrease the life time of catalytic converters.



CAUTION: Do not use two-stroke oil for water-cooled outboard engines, also referred to as outboard oil.



CAUTION: Do not use oil for four-stroke engines.

- For best results and performance use Husqvarna two-stroke oil.
- If Husqvarna two-stroke oil is not available, use a different two-stroke oil of good quality for air-cooled engines. Speak to your servicing dealer to select the correct oil.

Gasoline, l	Two-stroke oil, l
	2% (50:1)
5	0.10
10	0.20
15	0.30
20	0.40

To mix gasoline and two-stroke oil



CAUTION: There is a risk that small errors influence the ratio of the mixture drastically when you mix small quantities of fuel. Carefully measure the quantity of oil to be mixed to make sure that you get the correct mixture.

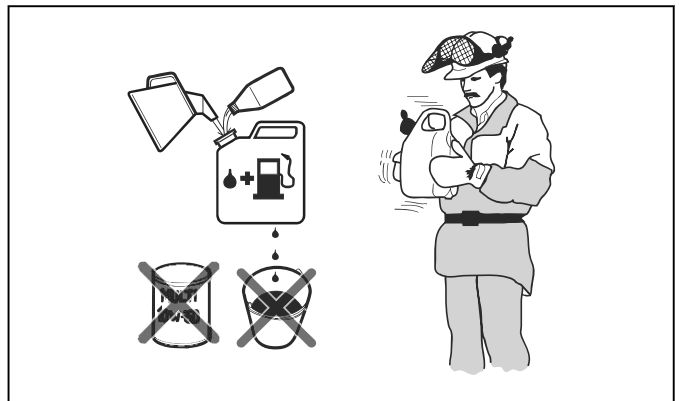

1. Fill half the quantity of the gasoline to be used.
2. Add the full quantity of oil and mix (shake) the fuel mixture.
3. Add the remaining quantity of gasoline.
4. Carefully mix (shake) the fuel mixture and fill the fuel tank of the product.
5. Empty and clean the fuel tank if you do not use the product for some time.

Note: Do not mix fuel for more than 1 month at a time and always mix gasoline and oil in a clean container intended for fuel.

To fill the fuel tank

1. Clean the area around the fuel tank cap.
2. Shake the container and make sure that the fuel is fully mixed. Use a fuel container with an anti-spill valve.
3. Fill the fuel tank.
4. Tighten the fuel tank cap carefully.
5. Move the product 3 m (10 ft) or more away from the refueling area and fuel source before starting.

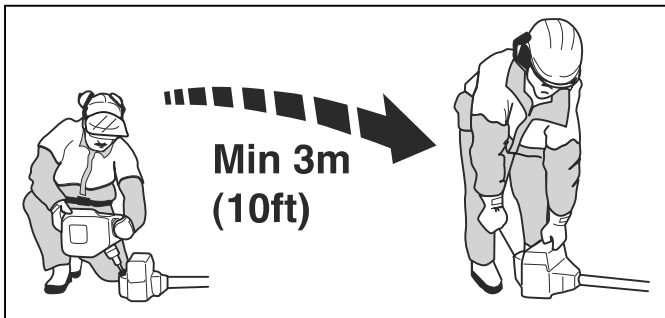

CAUTION: Contamination in the tanks causes malfunction. Clean the fuel tank and chain oil tank regularly and replace the fuel filter one time a year or more.

Before you operate the product

- Examine the work area to make sure that you know the type of terrain. Examine the slope of the ground and if there are obstacles such as stones, branches and ditches.
- Do an overall inspection of the product.
- Do the safety inspections, maintenance and servicing that are given in this manual.
- Make sure that all covers, trimmer guard and trimmer head correctly attached and not damaged or cracked. Replace if they are exposed to impact or cracked.

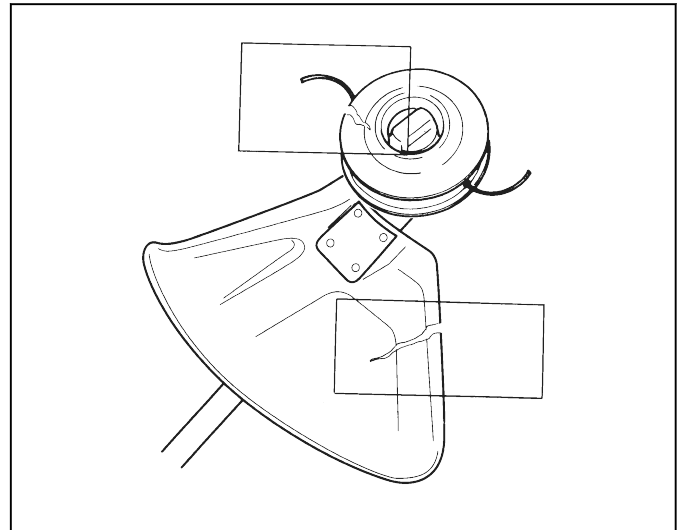

WARNING: Do not use the product without a guard or a with a damaged guard.

To prepare the product for start

1. Press the air purge again and again until the fuel starts to fill the bulb.

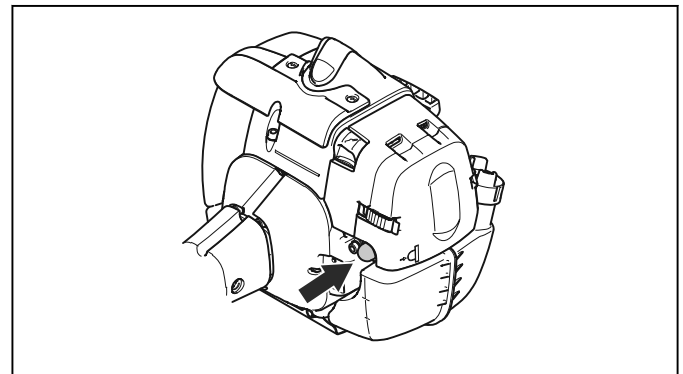

Note: It is not necessary to fully fill the bulb.

2. Move the choke control up into choke position.

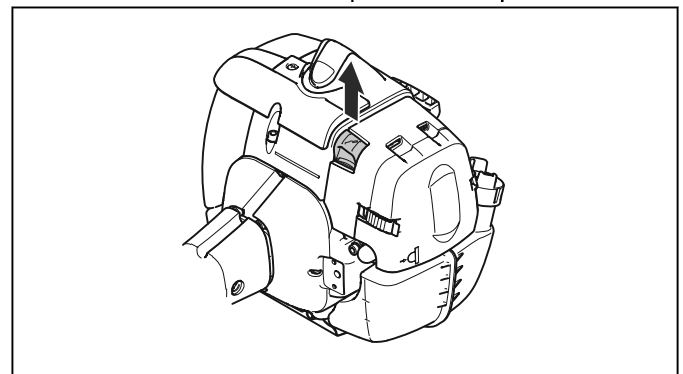

WARNING: The cutting attachment will start to rotate immediately when you start the engine with the choke.

To prepare a cold engine for start

1. Push the air purge bulb again and again until fuel starts to fill the bulb. It is not necessary to fill the air purge bulb fully.

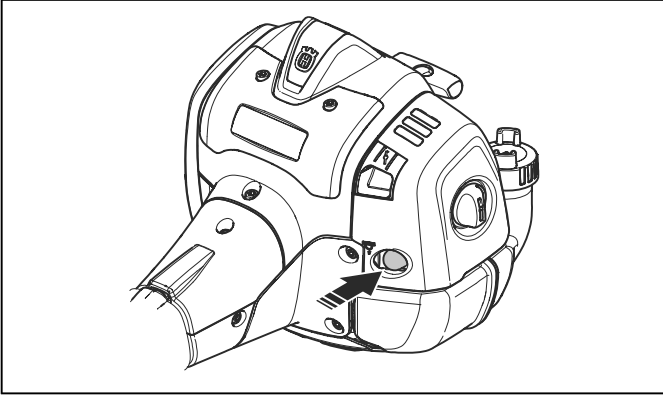

2. Move the choke control up into choke position.

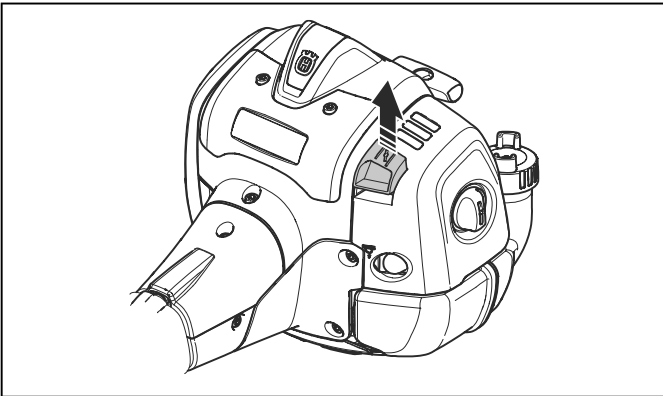

WARNING: The cutting attachment starts to rotate immediately when you start the engine with the choke.

To prepare a warm engine for start

1. Push the air purge bulb again and again until fuel starts to fill the bulb. It is not necessary to fill the air purge bulb fully.

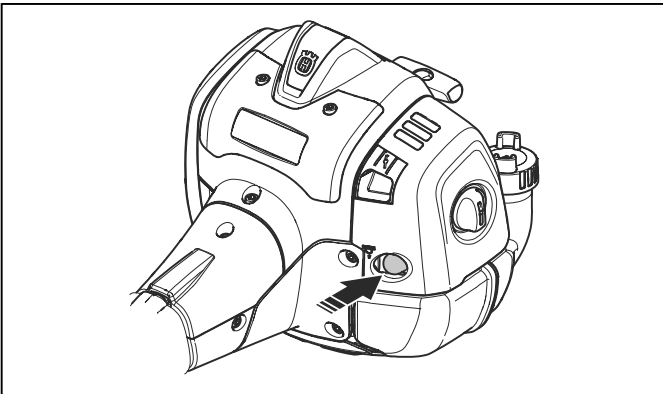

2. Pull the starter rope handle until the engine starts. Push the throttle trigger slowly to increase the speed gradually.



CAUTION: Do not pull the starter rope to full extension. Do not let go of the starter rope handle when the starter

rope is fully extended. This can cause damage to the product.

To start the product



WARNING: Read the warning instructions in the safety chapter before you start the product (refer to *Safety on page 4*).

1. Use protective gloves.
2. Hold the body of the product on the ground with your left hand.



CAUTION: Do not use your feet!

3. Hold the starter rope handle with your right hand.
4. Slowly pull out the starter rope with your right hand until you feel some resistance (the starter pawls grip).



WARNING: Do not twist the starter rope around your hand.

5. Pull the cord quickly and with power.



CAUTION: Do not pull the starter rope all the way out and do not let go of the starter rope handle when the starter rope is fully extended. This can cause damage to the product.

6. Pull the starter rope until the engine starts or for a maximum of 5 times.
7. Reset the choke when the engine starts or after you pull the starter rope 5 times.
8. If it is necessary, pull the starter rope again and again until the engine starts.
9. Let the engine run for 10 seconds.
10. Operate the throttle gradually.
11. Make sure the engine runs smoothly.

Note: If the engine stops, do the procedure again.

To stop the product

1. Move the stop switch into the stop position to stop the engine.

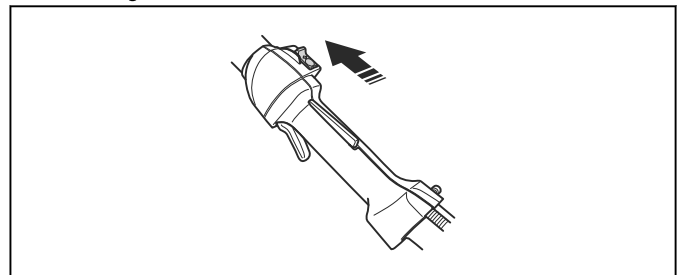



CAUTION: The stop switch automatically goes back to its initial position. In order to prevent accidental starting, the spark plug cap must be removed from the spark plug when assembling, checking and/or maintenance is done.

About the surface



WARNING: Do not touch the area that is identified with gray in the illustration. There is a risk of burn injuries when the product is hot. There is a risk of electrical shock if the spark plug cap is damaged. Do not use a product that has a damaged spark plug cap.

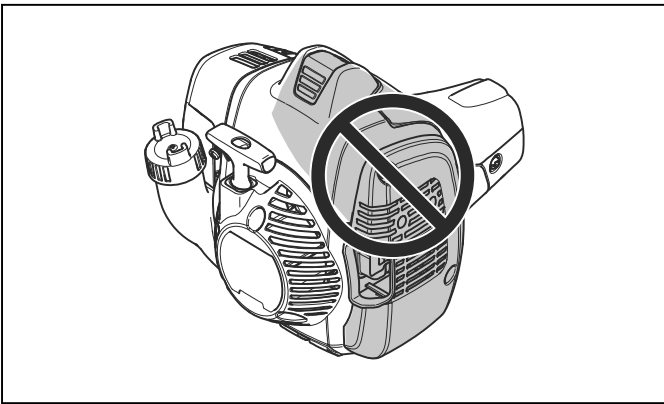

Grass trimming with a trimmer head

To trim the grass

1. Hold the trimmer head immediately above the ground at an angle. Do not push the trimmer line into the grass.

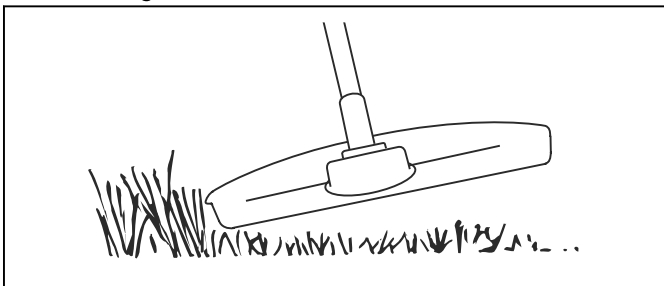

2. Decrease the length of the trimmer line by 10-12 cm / 4-4.75 in.
3. Decrease the engine speed to decrease the risk of damage to plants.

4. Use 80 % throttle when you cut grass near objects.

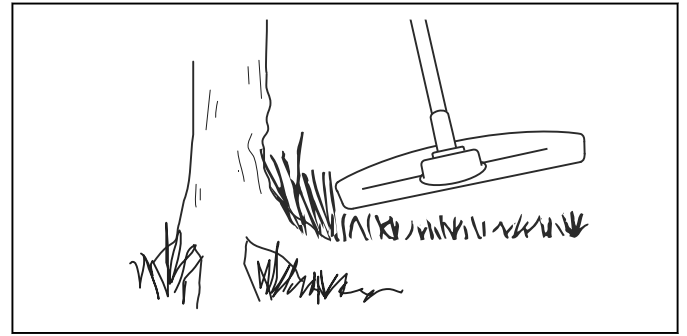

To cut the grass

1. Make sure that the trimmer line is parallel to the ground when you cut the grass.

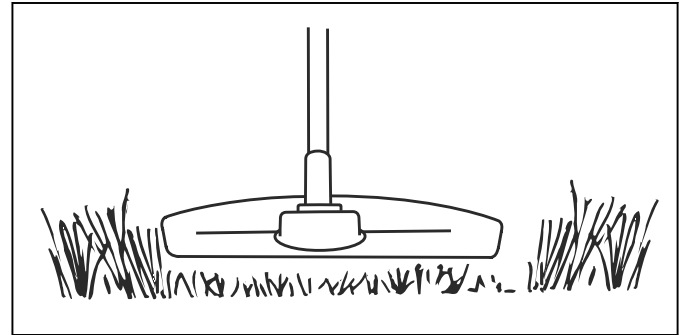

2. Do not push the trimmer head to the ground. This can cause damage to the product.
3. Move the product from side to side when you cut grass. Use full speed.

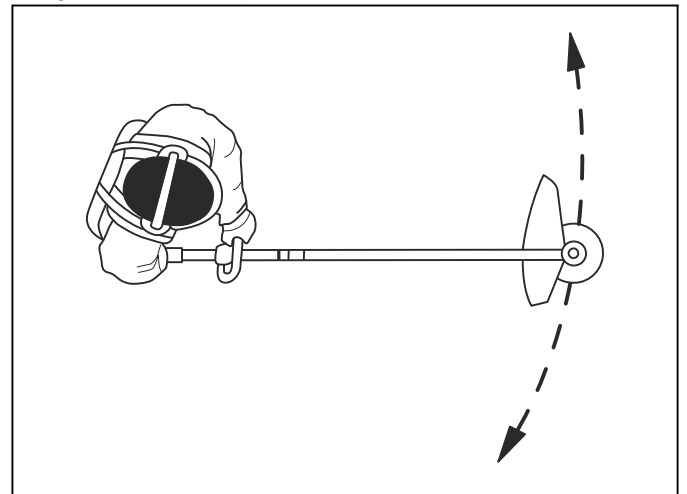

To sweep the grass

The airflow from the rotating trimmer line can be used to remove cut grass from an area.

1. Hold the trimmer head and the trimmer line parallel to the ground and above the ground.
2. Apply full throttle.
3. Move the trimmer head from side to side and sweep the grass.



WARNING: Clean the trimmer head cover each time you assemble new trimmer line to prevent unbalance and vibrations in

the handles. Also do a check of the other parts of the trimmer head and clean it if necessary.

Maintenance

Maintenance schedule

manual. For maintenance or servicing that is not given in this operator's manual, speak to your servicing dealer.



WARNING: Only do the maintenance and servicing given in this operator's

Maintenance	Daily	Weekly	Monthly
Clean the external surface.	X		
Make sure that the throttle trigger lockout and the throttle trigger operates correctly.	X		
Do a check of the stop switch to make sure that it operates correctly.	X		
Make sure that the cutting attachment does not rotate at idle speed.	X		
Clean the air filter. Replace the air filter if it is necessary.	X		
Examine the cutting attachment guard for damages and cracks. Replace the guard if it is hit or damaged.	X		
Examine the trimmer head for damages and cracks. Replace the trimmer head if it is damaged.	X		
Make sure that the screws and nuts are tight.	X		
Examine the engine, the fuel tank and the fuel lines for leaks.	X		
Clean the cooling system.		X	
Examine the starter and the starter rope for damages.		X	
Examine the vibration damping elements for damages and cracks.		X	
Clean the external parts of the spark plug. Remove it and do a check of the electrode gap. Adjust the electrode gap to the correct distance, refer to <i>Technical data on page 20</i> or replace the spark plug. Make sure that the spark plug is fitted with a suppressor.		X	
Clean the external parts of the carburetor and the area around it.		X	
Make sure that the bevel gear is filled correctly with grease, see <i>Bevel gear on page 19</i> . If not, use Husqvarna bevel gear grease.		X	
Clean or replace the spark arrestor mesh on the muffler (only applies to mufflers without a catalytic converter).			X
Do a check of the fuel filter for contamination and the fuel hose for cracks or other defects. Replace parts if it is necessary.			X
Do a check of all the cables and connections.			X
If it is necessary to replace the clutch, clutch springs or clutch drum, speak to your servicing dealer.			X
Replace the spark plug. Make sure that the spark plug is fitted with a suppressor.			X

To adjust the idle speed

1. Make sure that the air filter is clean and the air filter cover is installed.
2. Adjust the idle speed with the idle adjustment screw. The idle adjustment screw T is identified with a "T" mark.

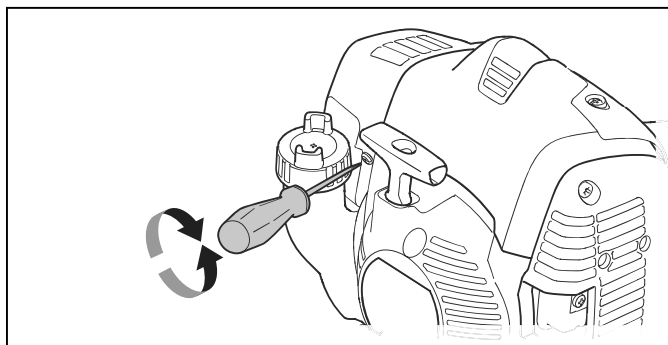

3. Turn the idle adjustment screw clockwise until the cutting attachment starts to turn.
4. Turn the idle adjustment screw counterclockwise until the cutting attachment stops.

The idle speed is correct when the engine operates smoothly in all positions. The idle speed must be below the speed when the cutting attachment starts to turn.



WARNING: If the cutting attachment does not stop when you adjust the idle speed, turn to your nearest servicing dealer. Do not use the product until it is correctly adjusted or repaired.

Note: Refer to *Technical data on page 20* for the recommended idle speed.

To do maintenance on the trimmer head

1. Only use the recommended cutting attachment and cutting attachment guard. Refer to *Accessories on page 21*.
2. Make sure that the cutter on the cutting attachment guard is not damaged, it cuts the cord to the correct length.
3. Install the cord as the illustrations on the last pages of the manual shows.

Cooling system

The product has a cooling system to keep the operation temperature as low as possible.

Clean the components of the cooling system with a brush weekly or more frequently in rougher conditions. A dirty or blocked cooling system makes the product too hot which causes damage to the piston and cylinder.

The cooling system has the following components:

1. Air intake on the starter.

2. Fins on the flywheel.
3. Cooling fins on the cylinder.
4. Cylinder cover.
5. Muffler cover.
6. Muffler plate.

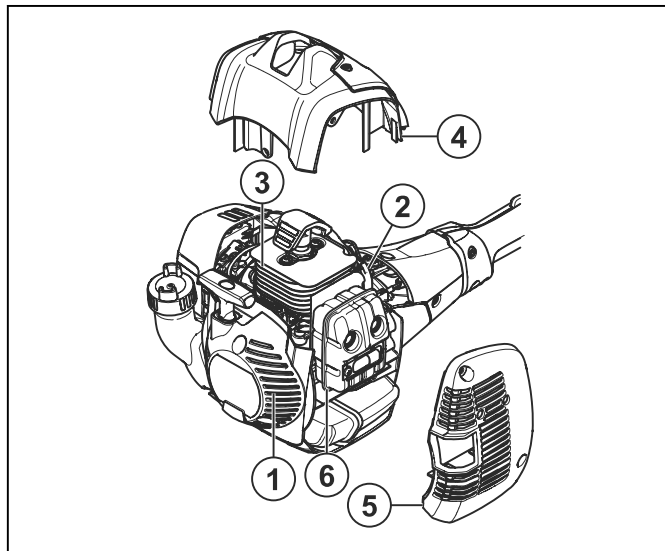

To do maintenance on the muffler

The muffler decreases the noise level and directs the exhaust gases away from the operator.



WARNING: Mufflers that have catalytic converters get very hot during operation and will stay hot for some time after you stop the product. This also applies at idle speed. If you touch the product it can result in burns to the skin. Think about the risk of fire.

1. Stop the product and let it cool down.
2. Remove the cover to the muffler.

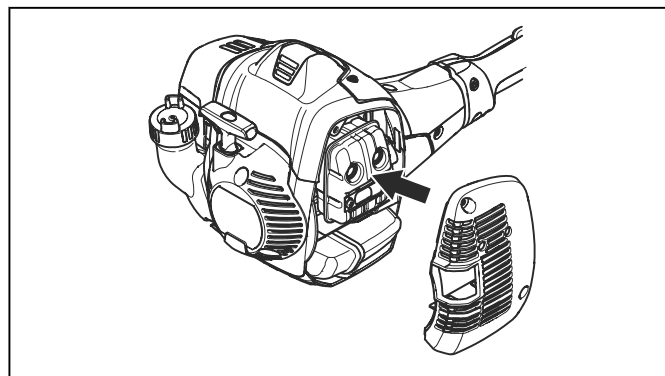

3. Remove the screw holding the spark arrestor mesh.

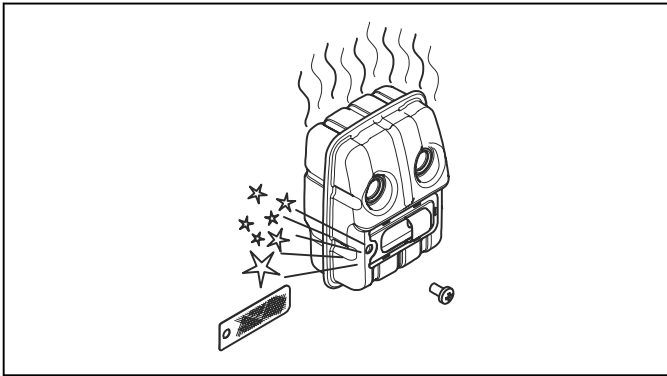

4. Clean the spark arrestor mesh if it is blocked or replace it if it is damaged.



CAUTION: The spark arrestor mesh must be replaced if it is damaged. Do not use a product if the spark arrestor mesh on the muffler is missing or damaged.



CAUTION: If the spark arrestor mesh is frequently blocked it can be a sign that performance of the catalytic converter is decreased. Turn to your servicing dealer to examine the muffler. A blocked spark arrestor mesh will cause overheating and result in damage to the cylinder and piston.

To do a check of the spark plug



CAUTION: Always use the recommended spark plug type. Incorrect spark plug type can cause damage to the product.

- Do a check of the spark plug if the engine is low on power, is not easy to start or does not operate correctly at idle speed.
- To decrease the risk of unwanted material on the spark plug electrodes, obey these instructions:
 - a) Make sure that the idle speed is correctly adjusted.
 - b) Make sure that the fuel mixture is correct.
 - c) Make sure that the air filter is clean.
- If the spark plug is dirty, clean it and make sure that the electrode gap is correct, refer to *Technical data on page 20*.

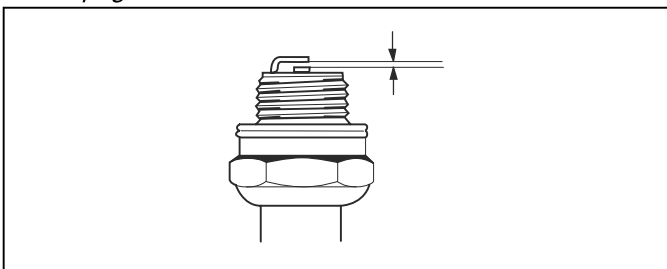

- Replace the spark plug if it is necessary.

Air filter

Remove dust and dirt from the air filter to keep it clean and prevent these problems:

- Carburetor malfunctions.
- Problems when you start the product.
- Loss of engine power.
- Increased wear to engine parts.
- Too much fuel consumption.

To clean the air filter



CAUTION: An air filter that is damaged, very dirty, or soaked with fuel must always be replaced.

Clean the air filter from dirt and dust regularly. This prevents carburetor malfunctions, starting problems, loss of engine power, wear to engine parts and more fuel consumption than usual.

If you use an air filter for a long time, it cannot be fully cleaned. Replace the air filter with a new one at regular intervals. Refer to *Maintenance schedule on page 16*.

1. Move the choke lever up to close the choke valve.

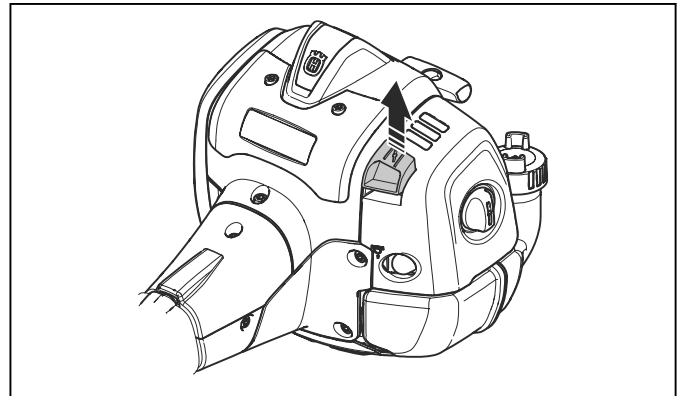

2. Remove the air filter cover and the air filters.

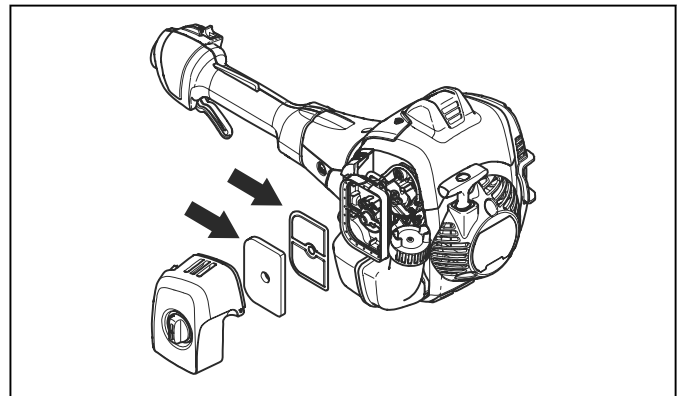

3. Clean the air filters with warm soap water.
4. Replace the air filters if they cannot be fully cleaned. Always replace a damaged air filter.
5. Clean the inner surface of the air filter cover. Use compressed air or a brush.
6. Do a check of the rubber seal on the air filter. Replace the air filter if the rubber seal is damaged.

7. Make sure that the air filter is dry before you install it.

Bevel gear

The bevel gear is filled with the right quantity of grease at the factory. But, before you use the product, make sure that the bevel gear is 3/4 full with grease. Use Husqvarna special grease.

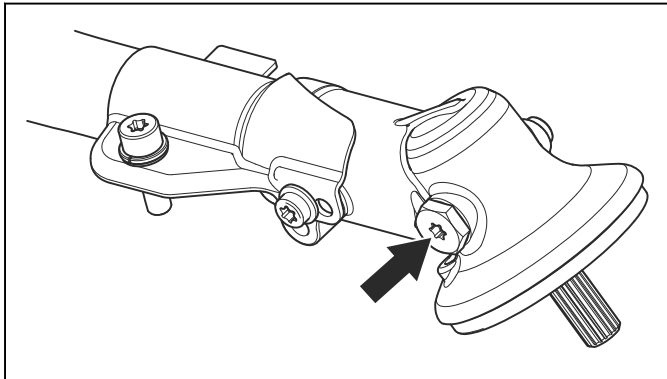

The grease in the bevel gear does not need to be changed unless repairs are carried out.

Two piece-shaft

Apply grease to the end of the drive shaft after each 30 hours of operation. There is a risk that the drive shaft ends (splined coupling) on models with two-piece shafts will seize if they are not lubricated regularly.

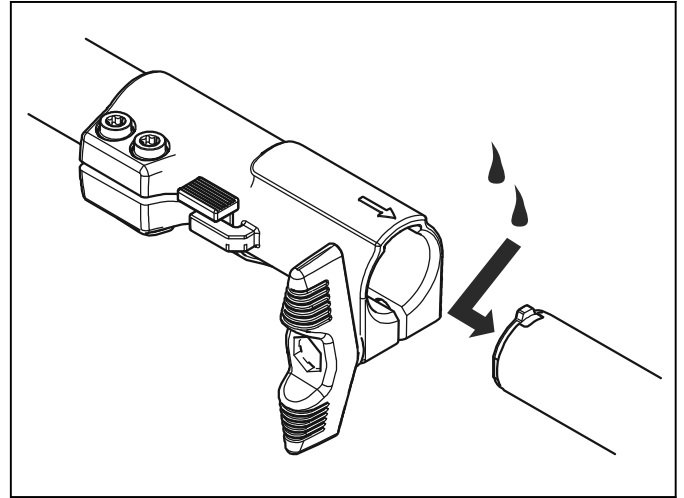

Troubleshooting

The engine does not start

Check	Possible cause	Procedure
Stop switch.	The stop switch is in the stop position.	Set the stop switch to the start position.
Starter pawls.	The starter pawls cannot move freely.	Remove the starter cover and clean around the starter pawls.
		Let an approved service agent help you.
Fuel tank.	Incorrect fuel type.	Drain the fuel tank and fill with correct fuel.
Spark plug.	The spark plug is dirty or wet.	Make sure that the spark plug is dry and clean.
	The spark plug electrode gap is incorrect.	Clean the spark plug. Make sure that the electrode gap is correct. Make sure that the spark plug has a suppressor.
		Refer to technical data for correct electrode gap.
	The spark plug is loose.	Tighten the spark plug.

The engine starts but stops again

Check	Possible cause	Procedure
Fuel tank.	Incorrect fuel type.	Empty the fuel tank and fill it with correct fuel.

Check	Possible cause	Procedure
Air filter.	The air filter is clogged.	Clean the air filter.

Transportation and storage

Transportation and storage

- Store and transport the product and fuel so that there is no risk that any leakage or fumes comes in contact with sparks or open flames, for example, from electrical machinery, electric motors, electrical relays/switches or boilers.
- When you store and transport fuel always use approved containers intended for this purpose.
- When you store the product for long periods the fuel tank must be emptied. Contact your local petrol station to find out where to dispose excess fuel. Drain the tank into the appropriate containers and in a well ventilated area.
- Ensure that the product is cleaned and that a complete service is carried out before long-term storage.
- The transport guard must always be fitted to the cutting attachment when the product is transported or in storage.
- Secure the product during transport.
- In order to prevent unintentional start of the engine, the spark plug cap must always be removed during long-term storage if the product is not under close supervision and when you perform all service measures.
- Allow the product to cool before you put in storage.

Technical data

Technical data

	525LK
Engine	
Cylinder displacement, cm ³	25.4
Idle speed, rpm	3000
Recommended max. speed, rpm	9500
Speed of output shaft, rpm	6500
Max. engine output, according to ISO 8893, kW/hp @ rpm	1.0 / 1.34 @ 8500
Catalytic converter muffler	Yes
Ignition system	
Spark plug	Husqvarna HQT-2
Electrode gap, mm	0.5
Fuel and lubrication system	
Manufacturer/type of carburetor	Walbro WTEA-8
Fuel tank capacity, litre	0.51
Weight	
Without fuel, cutting attachment and guard, kg	4.7

	525LK
Noise emissions ¹	
Sound power level, measured dB (A)	104
Sound power level, guaranteed L _{WA} dB (A)	106
Sound levels ²	
Equivalent sound pressure level at the operator's ear, measured according to EN ISO 11806 and ISO 7917, dB(A), min./max.:	
Equipped with trimmer head (original)	99
Vibration levels	
Equivalent vibration levels (a _{hv,eq}) at handles, measured according to EN ISO 11806 and ISO 22867, m/s ² :	
Equipped with trimmer head (original), left/right	3.0/3.3

Accessories

Accessories

The accessories are recommended for use in combination with the specified power heads and have been evaluated to applicable ISO- and EN safety requirement standards by the Swedish Machinery Testing Institute.

Approved accessories	Accessory type	Cutting attachment guard, art. no.
Blade shaft thread M10		
Plastic blades	Tricut Ø 255 mm (separate blades have part number 531 01 77-15)	588 54 37-01 / 588 11 79-01 503 93 42-02 / 503 97 71-01
	Tricut Ø 300 mm (separate blades have part number 531 01 77-15)	588 54 37-01

¹ Noise emissions in the environment measured as sound power (L_{WA}) in conformity with EC directive 2000/14/EC. Reported sound power level for the machine has been measured with the original cutting attachment that gives the highest level. The difference between guaranteed and measured sound power is that the guaranteed sound power also includes dispersion in the measurement result and the variations between different machines of the same model according to Directive 2000/14/EC.

² Reported data for equivalent sound pressure level has a typical statistical dispersion (standard deviation) of 1 dB (A).

Approved accessories	Accessory type	Cutting attachment guard, art. no.
Trimmer head	Trimmy Fix (Ø2.4 mm cord)	588 54 37-01 / 588 11 79-01 503 93 42-02 / 503 97 71-01
	Superauto II (Ø 2,4-2,7 mm cord)	588 54 37-01 / 588 11 79-01 503 93 42-02 / 503 97 71-01
	S35 (Ø 2,4-3,0 mm cord)	588 54 37-01 / 588 11 79-01 503 93 42-02 / 503 97 71 01
	T25 (Ø 2.0-2.7 mm cord)	588 54 37-01 / 588 11 79-01 503 93 42-02 / 503 97 71-01
	T35, T35x (Ø 2,4-3,0 mm cord)	588 54 37-01 / 588 11 79-01 503 93 42-02 / 503 97 71-01
	Alloy (Ø 2,0-3,3 mm cord)	588 54 37-01 / 588 11 79-01 503 93 42-02 / 503 97 71-01

Approved attachments	Use with
Clean sweep attachment SR600-2	525LK
Hedge trimmer attachment HA110	525LK
Hedge trimmer attachment HA850	525LK
Edger attachment EA850	525LK
Saw attachment PA1100	525LK
Trimmer attachment TA850	525LK
Extension attachment EX850	525LK
Cultivator attachment CA230	525LK
Blower attachment BA101	525LK
Bristle brush attachment BR600	525LK
Dethatcher attachment DT600	525LK
Brush cutter attachment BCA850-24	525LK

Declaration of Conformity

EU Declaration of conformity

We, **Husqvarna AB**, SE-561 82 Huskvarna, Sweden, tel: +46-36-146500, declare on our sole responsibility that the product:

Description	Grass trimmer
Brand	Husqvarna
Type / Model	525LK
Identification	Serial numbers dating from 2024 and onwards

complies fully with the following EU directives and regulations:

Regulation	Description
2006/42/EC	"relating to machinery"
2014/30/EU	"relating to electromagnetic compatibility"
2000/14/EC	"relating to the noise emissions in the environment"
2011/65/EU	"on the restriction of the use of certain hazardous substances in electrical and electronic equipment"

and that the following standards and/or technical specifications are applied: EN ISO 12100:2021, CISPR 12:2007+A1:2009, EN ISO 11806-1:2022, EN ISO 14982:2009, EN IEC 63000:2018



RISE SMP Svensk Maskinprovning AB, Box 7035, SE-750 07 Uppsala, Sweden has performed voluntary type examination on behalf of Husqvarna AB.

Certificate Number: SEC/13/2382

RISE SMP Svensk Maskinprovning AB, Box 7035, SE-750 07 Uppsala, Sweden, has also verified agreement with appendix V of the council's directive 2000/14/EG.

For information relating to noise emissions, refer to *Technical data on page 20*.

Huskvarna, 2024-01-05

A handwritten signature in black ink, appearing to read 'Stefan Holmberg', written over a horizontal line.

Stefan Holmberg, R&D Director, Technology Management, Husqvarna AB

Responsible for technical documentation

UK Declaration of conformity

We, **Husqvarna AB**, SE-561 82 Huskvarna, Sweden, tel: +46-36-146500, declare on our sole responsibility that the product:

Description	Trimmer
Brand	Husqvarna
Type / Model	525LK
Identification	Serial numbers dating from 2024 and onwards

complies fully with the following UK regulations:

Description
The Supply of Machinery (Safety) Regulations 2008
Electromagnetic Compatibility Regulations 2016
The Noise Emission in the Environment by Equipment for use Outdoors Regulations 2001, Schedule 8
The Restriction of the Use of Certain Hazardous Substances in Electrical and Electronic Equipment Regulations 2012

and that the following standards and/or technical specifications are applied: EN ISO 12100:2021, CISPR 12:2007+A1:2009, EN ISO 11806-1:2022, EN ISO 14982:2009, EN IEC 63000:2018

For information relating to noise emissions, refer to *Technical data on page 20*.

Huskvarna, 2024-01-05

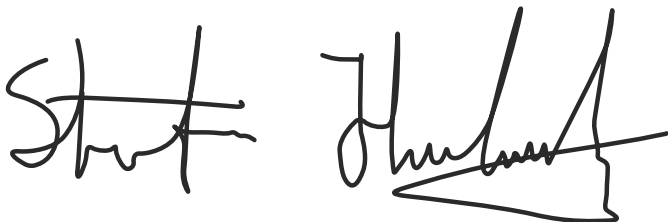

Stefan Holmberg, R&D Director, Technology Management, Husqvarna AB

Responsible for technical documentation

**UK
CA**

UK Importer:
Husqvarna UK Ltd
Preston Road, Co. Durham
DL5 6UP