



Operator's manual
HUSQVARNA AUTOMOWER®
305E/310E/405XE/410XE
NERA



EN, English

Read the operator's manual carefully and make sure that you understand the instructions before you use the product.

Contents

| | |
|--|----|
| 1 Safety | |
| 1.1 Safety definitions..... | 3 |
| 1.2 General safety instructions..... | 3 |
| 1.3 Safety instructions for installation..... | 4 |
| 1.4 Safety instructions for operation..... | 4 |
| 1.5 Safety instructions for maintenance..... | 5 |
| 1.6 Battery safety..... | 5 |
| 1.7 To lift and move the product..... | 5 |
| 2 Introduction | |
| 2.1 Introduction..... | 6 |
| 2.2 Support..... | 6 |
| 2.3 Product description..... | 6 |
| 2.4 Product overview..... | 7 |
| 2.5 Symbols on the product..... | 8 |
| 2.6 Symbols on the battery..... | 9 |
| 2.7 Symbols on the display..... | 9 |
| 2.8 Menu structure overview in Automower® | |
| Access..... | 10 |
| 2.9 Product damage..... | 11 |
| 3 Installation with virtual boundary | |
| 3.1 Introduction - Installation..... | 12 |
| 3.2 System overview for EPOS™ installation..... | 13 |
| 3.3 Primary components for installation..... | 13 |
| 3.4 To prepare for installation..... | 13 |
| 3.5 To examine where to put the reference station... | 14 |
| 3.6 To examine where to put the charging station.... | 14 |
| 3.7 To examine where to put the power supply..... | 15 |
| 3.8 To examine where to install the virtual | |
| boundaries..... | 15 |
| 3.9 To use the EPOS™ Support by wire function..... | 17 |
| 3.10 Installation of the product..... | 17 |
| 4 Installation with boundary wire | |
| 4.1 Introduction - Installation..... | 24 |
| 4.2 Primary components for installation..... | 24 |
| 4.3 To prepare for installation..... | 24 |
| 4.4 Before the installation of the wires..... | 24 |
| 4.5 Installation of the product..... | 29 |
| 5 Settings | |
| 5.1 Schedule..... | 33 |
| 5.2 Cutting height..... | 33 |
| 5.3 Pattern..... | 33 |
| 5.4 Operation..... | 34 |
| 5.5 Installation settings..... | 35 |
| 5.6 Accessories..... | 36 |
| 5.7 General..... | 36 |
| 5.8 Security..... | 36 |
| 5.9 Automower® Connect | 37 |
| 5.10 Messages..... | 37 |
| 5.11 Automower® Intelligent Mapping (AIM) | 37 |
| 5.12 Download firmware over the air FOTA | |
| (Firmware over the air)..... | 38 |
| 5.13 Mowing profiles..... | 38 |
| 5.14 To reinstall the charging station on the map.... | 38 |
| 6 Operation | |
| 6.1 To set the product to ON..... | 39 |
| 6.2 To start the product..... | 39 |
| 6.3 To park the product..... | 39 |
| 6.4 To stop the product..... | 39 |
| 6.5 To set the product to OFF..... | 39 |
| 6.6 To charge the battery..... | 40 |
| 7 Maintenance | |
| 7.1 Introduction - maintenance..... | 41 |
| 7.2 Maintenance schedule..... | 41 |
| 7.3 Clean the product..... | 42 |
| 7.4 Battery..... | 43 |
| 7.5 Replacement of the blades..... | 44 |
| 8 Troubleshooting | |
| 8.1 Messages..... | 45 |
| 8.2 LED indicator of the charging station..... | 52 |
| 8.3 Symptoms..... | 53 |
| 8.4 Finding breaks in the loop wire..... | 55 |
| 9 Transportation, storage and disposal | |
| 9.1 Transportation..... | 57 |
| 9.2 To put the product into storage..... | 57 |
| 9.3 To put the charging station into storage..... | 57 |
| 9.4 To install the charging station after storage..... | 57 |
| 9.5 Disposal..... | 58 |
| 10 Technical data | |
| 10.1 Technical data..... | 59 |

1 Safety

1.1 Safety definitions

Warnings, cautions and notes are used to point out specially important parts of the manual.



WARNING: Used if there is a risk of injury or death for the operator or bystanders if the instructions in the manual are not obeyed.



CAUTION: Used if there is a risk of damage to the product, other materials or the adjacent area if the instructions in the manual are not obeyed.

Note: Used to give more information that is necessary in a given situation.

1.2 General safety instructions



WARNING: Read the warning instructions that follow before you use the product.

- Read the Operator's manual carefully and make sure you understand the instructions before you use the product. Keep for future reference.
- This appliance is not intended for use by children or persons with reduced physical, sensory or mental capabilities (that could affect a safe handling of the product), or lack of experience and knowledge, unless they have been given supervision or instruction concerning use of the appliance by a person responsible for their safety. However, EU requirements allows this appliance to be used by children aged from 8 years and above and persons with reduced physical, sensory or mental capabilities or lack of experience and knowledge, if they have been given supervision or instruction concerning use of the appliance in a safe way and understand the hazards involved. Children shall not play with the appliance. Cleaning and user maintenance shall not be made by children without supervision.
- The product must only be used with the equipment recommended by Husqvarna. All other types of use are incorrect.
- To prevent damage to the product and accidents to vehicles and persons, do not install work areas and transport paths across public pathways.
- The product is not a toy. The blades of the product can cause injury to persons and animals.
- Do not let children less than 8 years of age be in the work area during operation. Children and animals must be supervised at all times during operation.
- All persons must be a minimum of 3 m/10 ft away from the product when it is in operation. Do not for example sleep or sunbathe in the work area when the product is in operation.
- Warning signs must be put around the work area of the product if it operates in public areas. The signs must have the text that follows: Warning! Automatic lawn mower! Keep away from the machine! Supervise children!
- Do not run when you operate the product manually with appDrive. Make sure that you have a safe and stable position at all times. Make sure that there are no persons near the product when it operates in steep slopes. Always wear substantial footwear and long pants when you operate the product with appDrive.
- To set the product to OFF, go behind the product and push the STOP button. You can use the app to pause the product if it is applicable for your product. When the product is set to OFF, wait minimum 3 seconds before you move the product.
- Set the product to OFF before you clear a blockage, do maintenance or examine the product, and if the product starts to vibrate abnormally. Examine the product for damage before you start the product again. Do not use the product if it is damaged.
- Do not touch moving hazardous parts, such as the blade disc, before it has come to a complete stop.
- If an injury or accident occur, get medical aid.
- Do not put power supply cable and extension cable in the work area. This can cause damage to the cables.
- Do not connect a damaged cable or plug, or touch a damaged cable, before it is disconnected from the power outlet. Disconnect the plug from the power outlet if the cable becomes damaged while in operation. A worn or damaged cable increases the risk of electrical shock. A damaged cable must be replaced by service personnel.
- When you connect the power supply to the power outlet, use a residual-current device (RCD) with a tripping current of maximum 30 mA.
- Only charge the product in the included charging station. For safe disposal of the battery, refer to *Disposal on page 58*. Incorrect use may result in electric shock, overheating or leaking of corrosive liquid from the battery. In the event of leakage of electrolyte, flush with water/neutralizing agent. Get medical aid if corrosive liquid comes in your eyes.

- Use only original batteries recommended by Husqvarna. Product safety cannot be guaranteed with other than original batteries. Do not use non-rechargeable batteries.
- Follow the installation instructions that includes to specify the work area, refer to *Introduction - Installation on page 12*.
- Follow the instructions about to start and operate the product, refer to *Operation on page 39*.
- If there is a risk of thunderstorm, Husqvarna recommends that the power supply and all the wires to the charging station are disconnected to decrease the risk of damage to electrical components. Connect the power supply and all the wires again if there is no longer a risk of thunderstorm. It is important that all wires are connected correctly.
- Follow the maintenance instructions and if necessary use Husqvarna original spare parts, refer to *Maintenance on page 41*.
- For technical data such as weight, dimensions and noise emission values, refer to *Installation of the product on page 29*.
- The operator is responsible for accidents or dangers that occurs to other persons or property.
- The product must only be operated, maintained and repaired by persons that are fully conversant with its special characteristics and safety regulations.
- It is not permitted to change the initial design of the product.
- Obey national regulations about electrical safety.
- Husqvarna does not guarantee full compatibility between the product and other types of wireless systems such as remote controls, radio transmitters or equivalent.
- The built-in alarm is very loud. Be careful, especially if the product is handled indoors.
- Operation and storage temperature range is 0-45 °C / 32-113 °F. Temperature range for charging is 5-45 °C / 41-113 °F. Too high temperatures can cause damage to the product.

1.3 Safety instructions for installation



WARNING: Read the warning instructions that follow before you use the product.

- Do not install the charging station, including any accessory, at a location that is below, or within 60 cm / 24 in. from, any combustible material. In case of malfunction, heating of the charging station and the power supply may occur and create a potential risk of fire.
- Do not put the power supply at a height where there is a risk it can be put in water. Do not put the power supply on the ground.

- Do not encapsulate the power supply. Condensed water can harm the power supply and increase the risk of electrical shock.
- Do not install the charging station where there are pests, for example ants.
- Applicable to USA/Canada. If power supply is installed outdoors: Risk of Electric Shock. Install only to a covered Class A GFCI receptacle (RCD) that has an enclosure that is weatherproof with the attachment plug cap inserted or removed.
- Do not install the charging station where there is a risk of standing water.

1.4 Safety instructions for operation



WARNING: Read the warning instructions that follow before you use the product.

- Keep your hands and feet away from the rotating blades. Do not put your hands or feet near or below the product when it is set to ON.
- Use the park mode or set the product to OFF when persons, especially children or animals are in the work area. Refer to *To set the product to OFF on page 39*. Husqvarna recommends to set the product to operate when the work area has no activity. The product can cause injury to animals at night in work area, for example hedgehogs. Refer to *Operating modes - Park on page 39*.
- Make sure that there are no objects such as stones, branches, tools or toys on the lawn. The blades can be damaged if it hits an object.
- Do not lift the product or move it when it is set to ON.
- Do not let the product collide with persons or animals. If a person or animal comes in the way of the product, stop the product immediately. Refer to *To stop the product on page 39*.
- Do not put objects on top of the product or its charging station.
- Do not use the product if the **STOP** button does not work.
- Always set the product to OFF when it is not in operation. The product can only start when you enter the correct PIN code.
- Do not use the product at the same time as a pop-up sprinkler. Use the *Schedule* function so the product and pop-up sprinkler do not operate at the same time. Refer to *Schedule on page 33*.
- Do not let the product operate when there is standing water in the work area. For example when heavy rain forms pools of water.

1.5 Safety instructions for maintenance



WARNING: Read the warning instructions that follow before you do maintenance on the product.

- Set the product to **OFF** when you do maintenance on the product.
- Do not use a high-pressure washer to clean the product. Do not use solvents to clean the product.
- Disconnect the plug to the charging station before you clean or do maintenance of the charging station.

1.6 Battery safety



WARNING: Read the warning instructions that follow before you use the product.

- Lithium-ion batteries can explode or cause fire if disassembled, short-circuited, exposed to water, fire, or high temperatures. Handle carefully, do not dismantle, open the battery or use any type of electrical/mechanical abuse. Avoid storage in direct sunlight.
- Do not use a damaged battery. Dispose the battery if it is damaged. Refer to *Disposal on page 58*.

1.7 To lift and move the product



WARNING: The product must be set to **OFF** before you lift the product. The product is disabled when the indicator on the **jog wheel** goes off.



CAUTION: Do not lift the product when it is parked in the charging station. It can cause damage to the charging station and/or the product. Push the **STOP** button and pull the product out of the charging station before you lift it.

To safely move the product from or in the work area:

1. Push the **STOP** button to stop the product.
2. Set the product to **OFF**.
3. Lift the product by the handle with the blade disc away from your body.

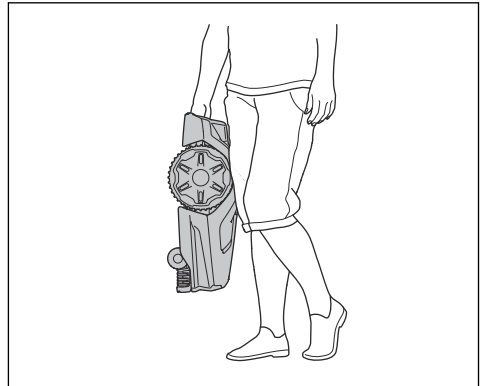

2 Introduction

2.1 Introduction

| |
|------------------------|
| Factory PIN code: 1234 |
| Serial number: |
| Product number: |

The serial number and the product number are on the product rating plate and on the product carton.

- Register your product on www.husqvarna.com. Enter the serial number of the product, the product number and the date of purchase to register your product.

2.2 Support

For support about the product, speak to your Husqvarna servicing dealer.

2.3 Product description

Note: Husqvarna regularly updates the appearance and function of the products. Refer to *Support on page 6*.

The product is a robotic lawn mower. The product has a battery power source and operates automatically. When the battery state of charge is low the product goes to the charging station to charge. The product starts to operate again when the battery is fully charged.

The product has EdgeCut which makes the product cut the edges of your lawn. The frequent cutting technique improves the grass quality and decreases the use of fertilizers. Collection of grass is not necessary.

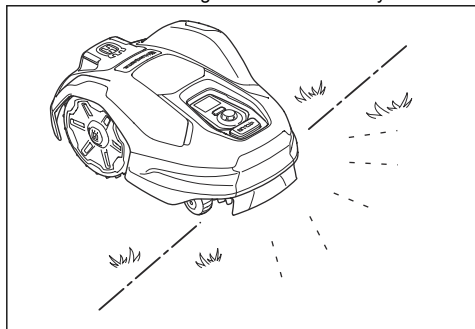

2.3.1 Installation method

You can install the product with virtual boundaries with EPOS™ technology or physical boundaries with boundary wire.

For installation with EPOS™, refer to *Installation with virtual boundary on page 12*. For installation of the boundary wire, refer to *Installation with boundary wire on page 24*.

2.3.2 Automower® Access

Automower® Access is the user interface on the product. It includes the display, the **jog wheel**, the **START** button and the **STOP** button. Refer to *Menu structure overview in Automower® Access on page 10*.

2.4 Product overview

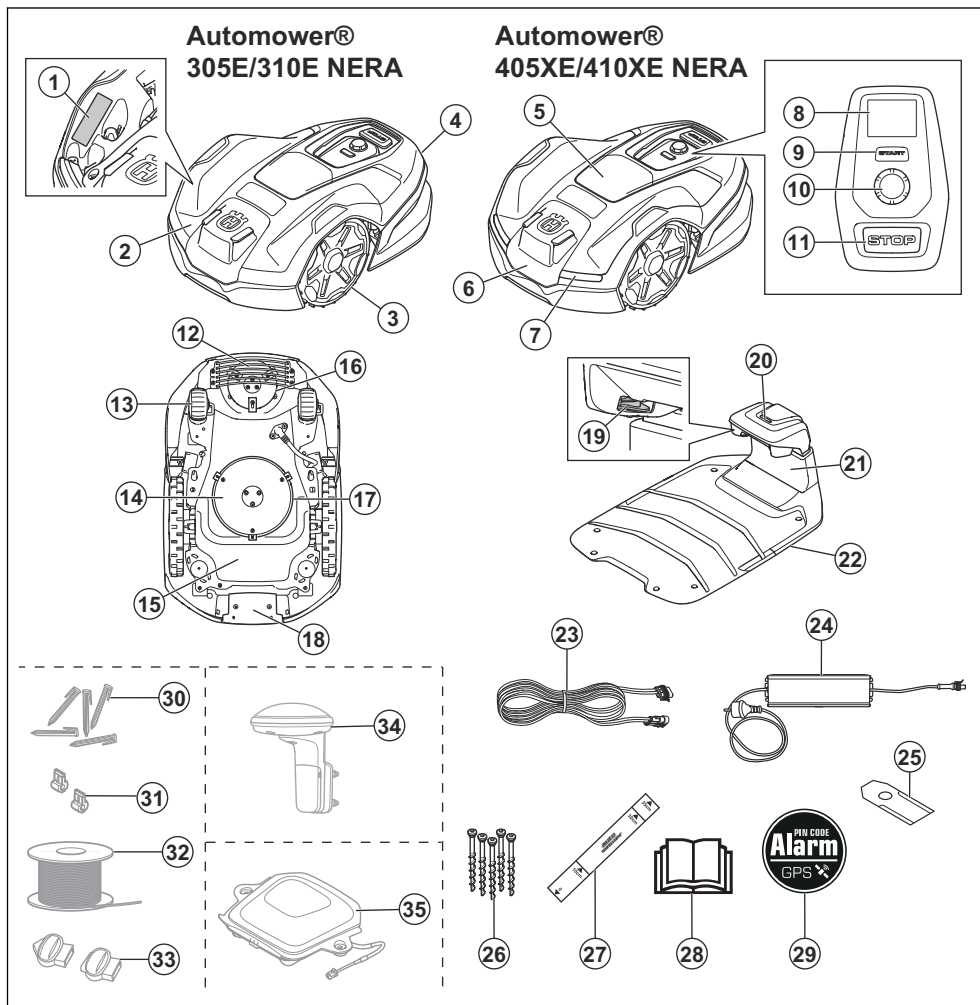

1. Rating plate¹
2. Top cover
3. Front wheels
4. Product body
5. EPOS™ hub
6. Radar²
7. Headlights³

8. Display
9. START button
10. Jog wheel
11. STOP button
12. Blade disc guard
13. Rear wheels
14. Skid plate

¹ Found below the top cover.

² Only for Automower® 405XE/410XE NERA.

³ Only for Automower® 405XE/410XE NERA.

15. Chassis with electronics, battery and motors
16. EdgeCut blade disc
17. Main blade disc
18. Handle
19. Contact plates
20. LED indicator of the charging station
21. Hatch
22. Charging station
23. Low-voltage cable
24. Power supply⁴
25. Extra blades
26. Screws to attach the charging station
27. Measurement gauge for installation of the boundary wire (the measurement gauge is removed from the carton of the product)
28. Operator's manual and Quick guide
29. Alarm decal
30. Stakes⁵
31. Connectors for the loop wire⁶
32. Loop wire for boundary wire and guide wire⁷
33. Couplers for the loop wire⁸
34. Reference station EPOS™ RS1⁹
35. Automower® EPOS™ Plug-in¹⁰



WARNING: Read the operator instructions before you operate the product.



WARNING: Disable the product before maintenance or before you lift the product.



WARNING: Keep a safe distance from the product when it is in operation. Keep your hands and feet away from the rotating blades of the product.



WARNING: Do not sit on the product. Do not put your hands or feet near or below the product.

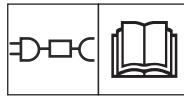

Use a detachable power supply as specified on the rating plate adjacent to the symbol.

2.5 Symbols on the product

These symbols can be found on the product. Make sure that you understand them.



This product complies with the applicable EU Directives.



This product complies with the applicable UK Directives.



It is not permitted to dispose the product as usual domestic waste. Obey national regulations and use the local recycling system.



The chassis contains components which are sensitive to electrostatic discharge (ESD). The chassis must only be opened and sealed by an authorized service technician. The warranty will not be applicable if the seal is broken.

⁴ The appearance can be different for different markets.

⁵ Purchased separately.

⁶ Purchased separately.

⁷ Purchased separately.

⁸ Purchased separately.

⁹ Purchased separately.

¹⁰ Purchased separately.



Do not make modifications on the low-voltage cable.
Do not use a hedge trimmer or a grass trimmer near the low-voltage cable.

2.6 Symbols on the battery



WARNING: Lithium-ion batteries can explode or cause fire if disassembled, short-circuited or handled roughly. Do not expose to water, fire or high temperature.



Read the user instructions.



Do not discard the battery into fire and do not expose the battery to a heat source.



Do not immerse the battery into water.

2.7 Symbols on the display



The product is in operation.



The product is parked.



The product is paused.



There is an error.



Cutting height of the product.



Cellular signal strength.



Wi-Fi signal strength.



Bluetooth® connection is enabled.



The battery is charging.



Battery level.

2.8 Menu structure overview in Automower® Access

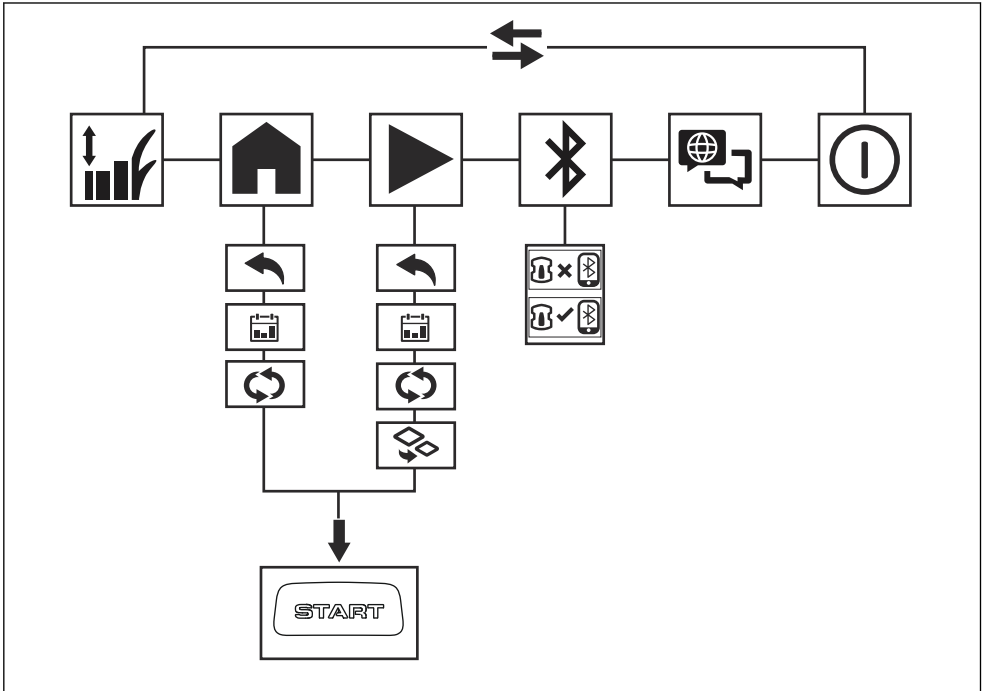

2.8.1 Symbols in the main menu for Automower® Access



Cutting height

In the *Cutting height* menu you can adjust the cutting height.



Park

In the *Park* menu you can set the product to park until further notice or to the set schedule.



Mow

In the *Mow* menu you can set the product to cut to the set schedule or in secondary area mode.



Connect

In the *Connect* menu you can enable Bluetooth® and make a pairing operation with your mobile device.



Language

In the *Language* menu you can select a language in the display.



Power off

Power off sets the product to OFF.

2.8.2 Symbols in the submenu for Automower® Access



Back

If you select *Back*, you go back to the main menu.



Schedule

In the *Schedule* submenu you can select the *Schedule* settings. The *Schedule* settings are set in the Automower® Connect app.



Selected operation mode

If you only have one work area, you can select to override the schedule and continue to cut until you change the operation mode.

If you have more than one work area you can select to override the schedule and only cut one of the work areas. For work areas with irregular mowing, the product will cut this area until you change the operation mode. For systematic work areas, the product will cut until the area is completed and then it will park in the charging station.

2.9 Product damage

We are not responsible for damages to our product if:

- the product is incorrectly repaired.
- the product is repaired with parts that are not from the manufacturer or not approved by the manufacturer.
- the product has an accessory that is not from the manufacturer or not approved by the manufacturer.
- the product is not repaired at an approved service center or by an approved authority.



Secondary area

In the *Secondary area* submenu you can select the *Secondary area* operation mode. Refer to *Secondary area on page 39*.



Connected

The product and mobile device are connected with Bluetooth®.



Not Connected

The product and mobile device are not connected with Bluetooth®.

2.8.3 Symbols in the app



Shows the status of the correction data that the product receives.

The status is *EPOS™ confirmed*. The product has an accurate position and direction. This is necessary to operate the product automatically and for the installation of map objects.



The status is *EPOS™ action is necessary*. The product has an accurate position but it is necessary to operate the product, manually or automatically, to get an accurate direction.



The status is *EPOS™ searching*. The product does not have an accurate position and is searching for the satellite signals and the correction data to get an accurate position.



3 Installation with virtual boundary

3.1 Introduction - Installation



WARNING: Read and understand the safety chapter before you install the product.



CAUTION: Use original spare parts and installation material.

Note: Refer to www.husqvarna.com for more information about installation.

For installation of virtual boundaries with EPOS™, the product uses satellites and correction data to navigate. The correction data can be received through the Husqvarna® Cloud or a reference station. The reference station is an optional accessory that you can use if you cannot connect to the Husqvarna® Cloud.

Note: All countries do not support reference stations or correction data through the Husqvarna® Cloud. Speak to your local Husqvarna representative for information.

To make an installation the product is operated with appDrive in the Automower® Connect app. Waypoints are added to make a map in the app.

Work areas are the areas where the product operates and cuts grass. You can also create stay-out zones where the product cannot enter.

In front of the charging station there is a docking point. It is used for the product to navigate to and from the charging station.

Transport paths are necessary to navigate between the docking point and the work areas. The product does not cut grass when it operates along a transport path. Refer to *System overview for EPOS™ installation on page 13*.

3.2 System overview for EPOS™ installation

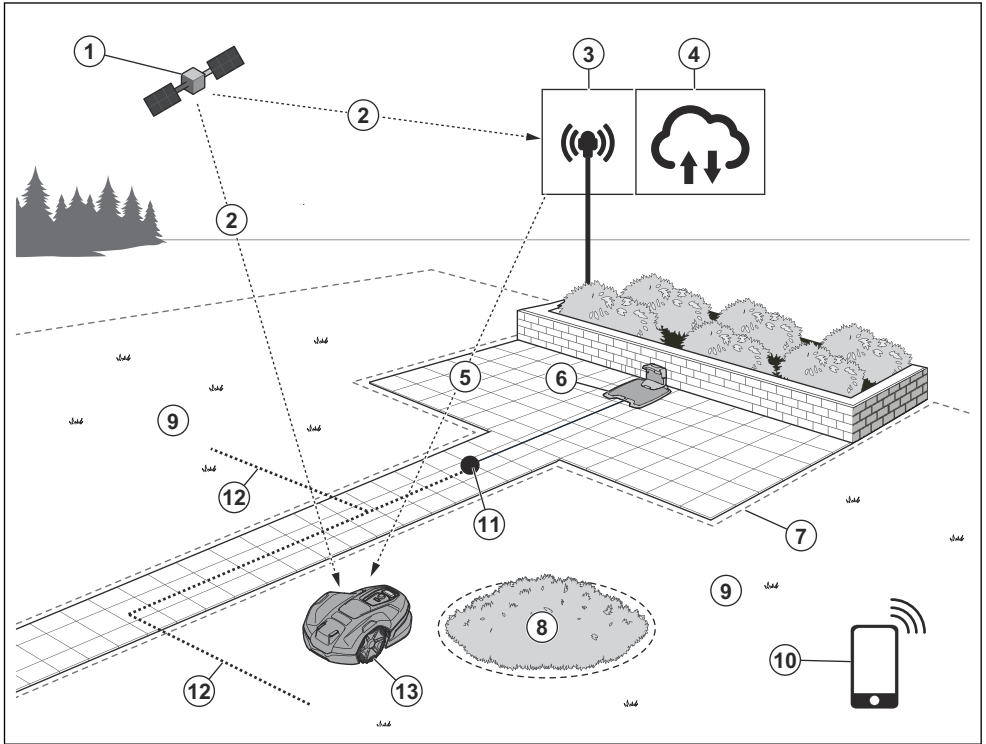

1. Satellites
2. Satellite signals
3. Reference station¹¹
4. Husqvarna® Cloud
5. Correction data
6. Charging station
7. Virtual boundary
8. Stay-out zone
9. Work area
10. Mobile device
11. Docking point
12. Transport path
13. Robotic lawn mower

- Charging station, that charges the product.
- Power supply, which is connected to the charging station and a 100-240V power outlet.
- Reference station¹², that receives satellite signals and sends correction data to the robotic lawn mower.
- Mobile device with the Automower® Connect app to do the installation and the settings for the product.

3.3 Primary components for installation

The installation includes the components that follow:

- Robotic lawn mower, that cuts the lawn automatically.

3.4 To prepare for installation



CAUTION: Holes with water in the lawn can cause damage to the product.



CAUTION: Read the installation chapter before you start the installation.

¹¹ Optional accessory which is purchased separately.

¹² Optional accessory which is purchased separately.

- If you use EPOS™ through Husqvarna® Cloud, make sure that the product can receive correction data in the complete work area.

Note: Cellular coverage or Wi-Fi is necessary to receive correction data for the product through Husqvarna® Cloud. Automower® 405XE/410XE NERA must have cellular coverage and Automower® 305E/310E NERA must have Wi-Fi coverage in the complete work area. If this is not possible, you can use a local reference station to receive correction data as an alternative.

- Make a blueprint of the work area and include all obstacles. This makes it easier to examine where to put the charging station, the virtual boundaries and the reference station.
- Make a mark on the blueprint where to put the charging station, the maintenance point, the transport paths, the virtual boundaries, stay-out zones and the reference station.
- Fill in holes in the lawn to make it level.
- For Automower® 305E/310E NERA, make sure that you have Wi-Fi coverage in the charging station to download new firmware. Refer to *Download firmware over the air FOTA (Firmware over the air) on page 38*. For Automower® 405XE/410XE NERA Wi-Fi or cellular technology is used for FOTA.
- For Automower® 305E/310E NERA, make sure that you have Wi-Fi coverage in the work area if you use the Automower® Connect app remotely. Refer to *To do a pairing operation with the Automower® Connect app on page 19*. For Automower® 405XE/410XE NERA Wi-Fi or cellular technology is used for Automower® Connect.
- Cut the grass before you install the product. Make sure that the grass is maximum 6 cm / 2.5 in.

Note: The first weeks after installation the sound level when the product cuts the grass can be higher than usual. The sound level decreases after some time.

3.5 To examine where to put the reference station

Read and understand the instructions about where to put the reference station. Refer to the Operator's manual for the reference station.

3.6 To examine where to put the charging station

- You can put the charging station inside or outside the work area.
- If the docking point is outside the work areas, install a transport path from the docking point to the work areas.

- Put the charging station (A) in an open area.
- Set the docking point between 70-250 cm / 28-98 in. from the charging station. Make sure that the docking point (B) has unimpeded sky view.
- Make sure to have sufficient of free space in front of the charging station.

Note: Husqvarna recommends to have a minimum of 6 m / 20 ft. (C) free space in front of the charging station.

- The reversing distance can be set to 70-250 cm / 28-98 in.

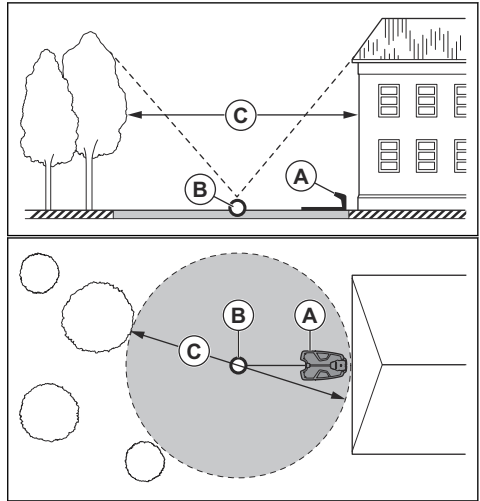

Note: Short reversing distance decreases the risk of track marks. A long reversing distance can be necessary to have good satellite signals at the docking point.

- Put the charging station near a power outlet.
- Put the charging station on a level surface.
- The baseplate of the charging station must not be bent.
- If the work area has 2 parts separated with a steep slope, Husqvarna recommends to put the charging station in the lower section.



CAUTION: Do not install the charging station where there are metal objects in the ground. Metal objects can cause interference with the charging station signal.

3.7 To examine where to put the power supply



CAUTION: Make sure that the blades on the product do not cut the low-voltage cable.



CAUTION: Do not put the low-voltage cable in a coil or below the charging station plate. The coil causes interference with the signal from the charging station.



- Put the power supply in an area with a roof and protection from the sun and rain.
- Put the power supply in an area with good airflow.
- Use a residual-current device (RCD) with a tripping current of maximum 30 mA when you connect the power supply to the power outlet.

Low-voltage cables of different lengths are available as accessories.

3.8 To examine where to install the virtual boundaries



CAUTION: If the work area is adjacent to water bodies, slopes, precipices or a public road, there must be a protective wall. The wall must be minimum 15 cm / 6 in. in height.



CAUTION: Do not let the product operate on gravel.

- For careful operation without noise, make stay-out zones around all obstacles for example trees, roots and stones.
- Make a blueprint of the work area before you install the virtual boundaries.

3.8.1 To install map objects near buildings and trees

- Make sure that 90° section of the sky is unimpeded where the product operates.

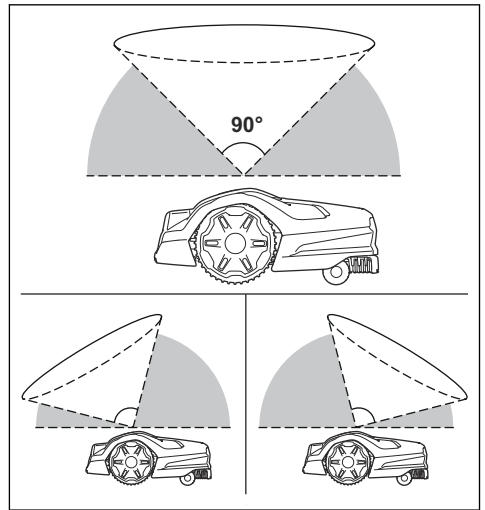

Note: The product cannot receive signals from the satellite for navigation if the sky is impeded.

- Make a stay-out zone (B) around trees or a group of trees with tree canopies that are more than 4 m / 13 ft. in diameter (A).

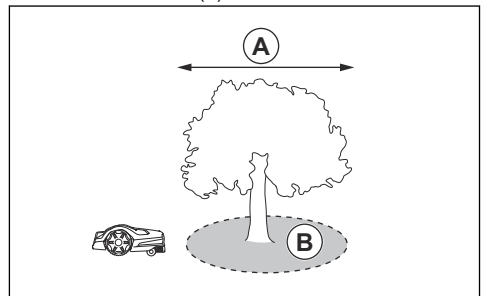

Note: Trees or a group of trees with tree canopies that are more than 4 m / 13 ft. in diameter (A) can cause temporary stops for the product. Smaller trees do usually not cause interference with the operation of the product.

- For L-shaped buildings, install the virtual boundary at a minimum distance (C) of 1.5 m / 5 ft. from it.

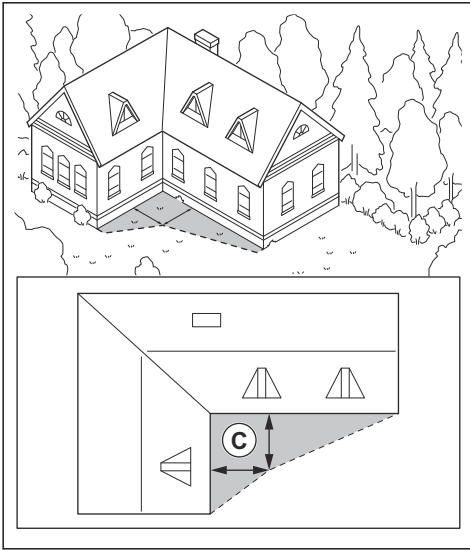

- To install virtual boundaries in an area with an U-shaped building, make sure that the distance (E) is minimum 6 m / 20 ft. If the building is higher than 3 m / 10 ft., make sure that the distance (E) is twice the height of the highest building. Install the virtual boundary at a minimum distance (D) of 1.5 m / 5 ft. from the building.

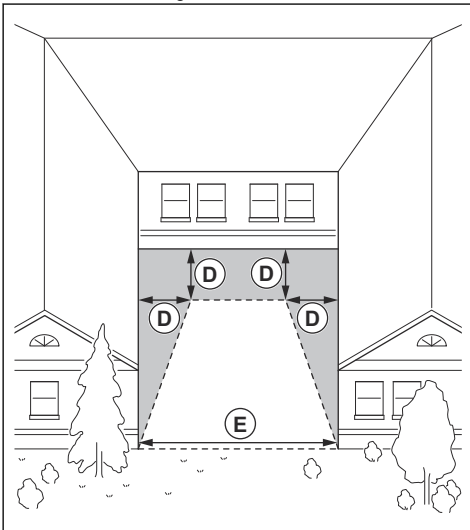

- Make sure that the areas between objects have a distance (F) of minimum 4 m / 13 ft.

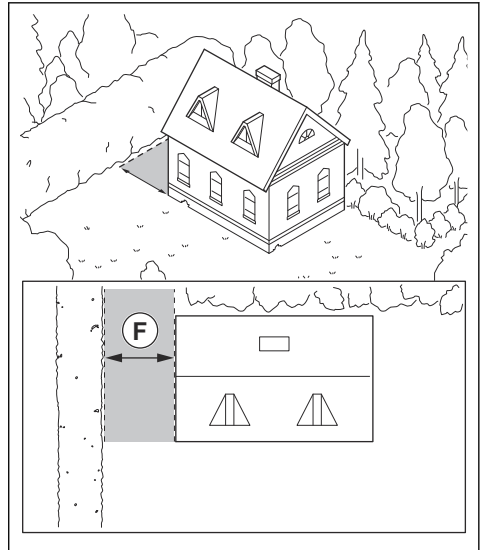

Note: For areas with a width less than 4 m / 13 ft. a transport path can be made for the robotic lawn mower to go through without cutting.

3.8.2 To install the map objects in a slope

The product can operate in 30% slopes in the work area. At the virtual boundaries the maximum slope is 20%. The slope (%) is calculated as height for each m. Example: 10 cm / 100 cm = 10%.

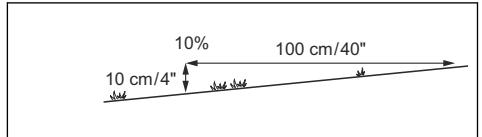

- For slopes more than 30% in the work area, isolate the slope with a stay-out zone.
- For slopes adjacent to a public road, put a fence or a protective wall along the outer edge of the slope.
- Husqvarna recommends to set the direction of the systematic pattern straight up the slope to prevent wear on the grass.

3.8.3 Passages

A passage is a section that has virtual boundary on each side and that connects 2 parts of the work area. The width of the passage can be minimum 2 m / 6.5 ft. to get a good cutting result.

3.8.4 To examine where to make stay-out zones

- Make stay-out zones around objects that are larger than 2x2 m / 6.6x6.6 ft.
- Make sure that the stay-out zone is minimum 30x30 cm / 1x1 ft.
- Make sure that the stay-out zone includes the complete area (A) where the product must not enter.

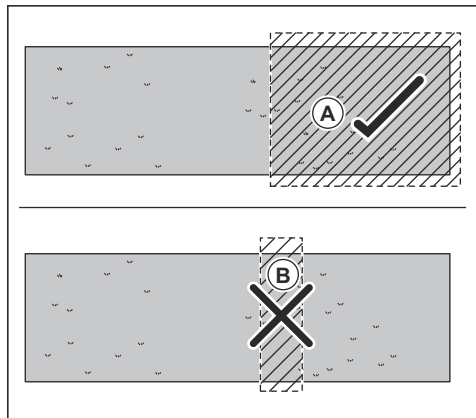

Note: Do not make a stay-out zone (B) across the work area to prevent the product to enter parts of the work area.

3.9 To use the *EPOS™ Support by wire* function

The boundary wire can be installed to operate with the EPOS™ system. Install the boundary wire if the satellite signals are weak. It can be in a part of the work area or an area where you have installed a transport path.

Note: Do not use the boundary wire to extend the work area.

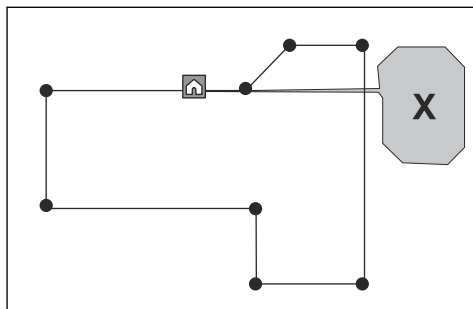
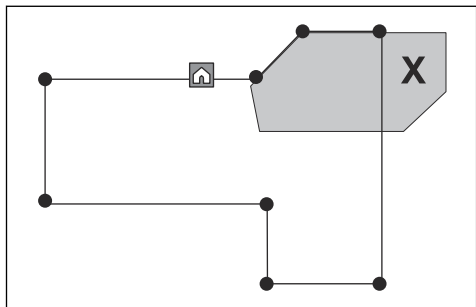

- Put a part of the boundary wire (A) approximately 2 m / 6.6 ft from the area where the satellite signal is weak.

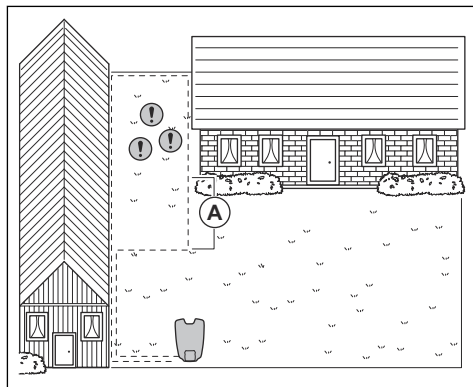

- Enable the *EPOS™ Support by wire* function when the boundary wire is installed. Select *Accessories > EPOS™ Support by wire > Enable* in the Automower® Connect app.
- Extend the boundary wire in the work area if the product continues to stop in a part of the work area.
- Extend the boundary wire in the work area if the product cannot move from the area with boundary wire.

3.10 Installation of the product

3.10.1 Installation tools

- Hex key, 8 mm. Included in the carton.

3.10.2 Installation of the charging station

Read and understand the instructions about the charging station. Refer to *To examine where to put the charging station on page 14*.



CAUTION: Do not make new holes in the charging station plate.



CAUTION: Do not put your feet on the baseplate of the charging station.



WARNING: Make sure that the plugs of the low-voltage cable and the power supply unit are clean and dry before you connect them.

When you connect the power supply, only use a power outlet that is connected to a residual-current device (RCD).

3.10.2.1 To install the charging station



CAUTION: Do not make new holes in the charging station plate.



CAUTION: Do not put your feet on the baseplate of the charging station.



WARNING: Make sure that the plugs of the low-voltage cable and the power supply unit are clean and dry before you connect them.

When connecting the power supply, only use a power outlet that is connected to an residual-current (RCD) device.

1. Read and understand the instructions about the charging station. Refer to *To examine where to put the charging station on page 14*.
2. Put the charging station in the selected area.
3. Open the hatch on the front of the charging station.
4. Attach the top of the charging station.

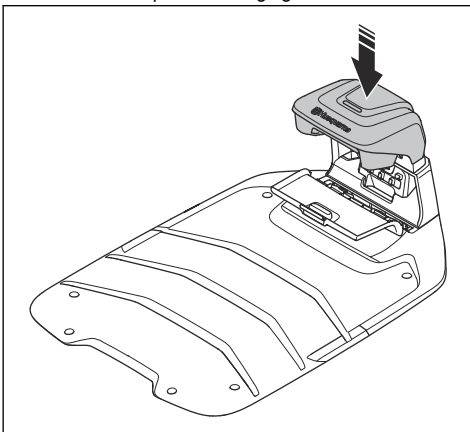

5. Lift and tilt the top of the charging station.
6. Put the grommet with the cables into position.
7. Connect the cable to the charging station.

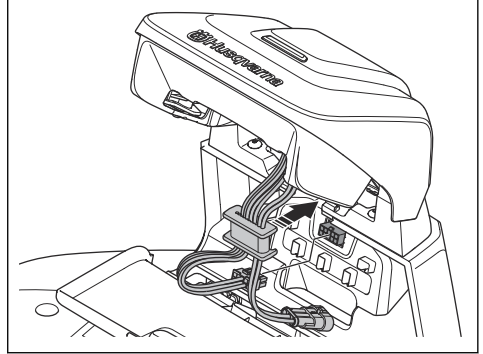

8. Connect the low-voltage cable to the charging station.
9. Close the hatch on the front of the charging station.
10. Put the power supply at a minimum height of 30 cm / 12 in.

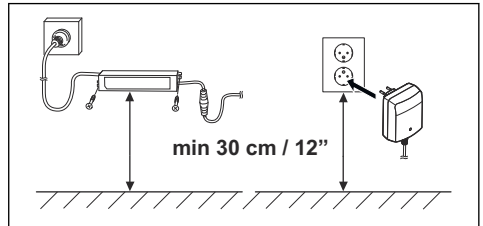

11. Connect the power supply cable to a 100-240V power outlet.
12. Put the low-voltage cable in the ground with stakes or bury the cable.
13. Attach the charging station to the ground with the supplied screws.

3.10.2.2 To do a visual check of the charging station

1. Make sure that the indicator LED lamp on the charging station has a green light. Refer to *LED indicator of the charging station on page 52* for information about the LED indicator.

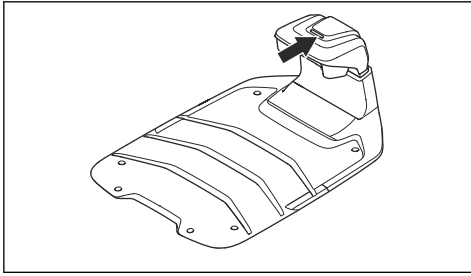

- If the indicator LED lamp does not have a green light, do a check of the installation. Refer to *LED indicator of the charging station on page 52* and *Installation of the charging station on page 17*.

3.10.3 To charge the product

- Put the product in the charging station.

Note: The product starts to charge automatically when the product is in the charging station.

3.10.4 To do a pairing operation with the Automower® Connect app

- Download the Automower® Connect app on your mobile device.
- Sign up for a Husqvarna account in the Automower® Connect app and follow the instructions.
- Enter the factory PIN code 1234 on the product.
- Use the jog wheel on the product to select the Bluetooth® menu to enable the pairing operation mode.
- Select *My mowers* in the Automower® Connect app and add your product.
- Follow instructions in the Automower® Connect app.

Note: Husqvarna recommends to change the factory PIN code to a new PIN code in the app.

3.10.5 Installation of the EPOS plug-in

Follow the instructions for installation in the operator's manual for Automower® EPOS™ Plug-in.

3.10.6 To enable EPOS™ in the Automower® Connect app

Enable EPOS™ in the Automower® Connect app to do an installation with virtual boundaries.

- Select *Settings > Accessories > EPOS™ Technology* in the Automower® Connect app.

3.10.7 Installation of the reference station

Install the reference station according to the instructions in the Operator's manual for the reference station.

3.10.8 Installation of the map objects

Read and understand the instructions about where to install the map objects. Refer to *To install objects on the map on page 20*.

On the map you can install the objects that follow in the app:

- *Work areas (A)*
- *Stay-out zones (B)*
- *Transport path (C)*
- *Charging station (D)*
- *Maintenance point (E)*
- *Work area (Secondary area) (F)*

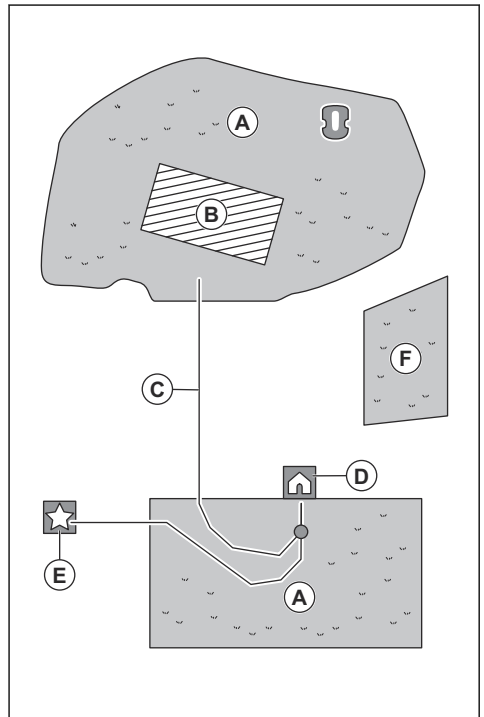

For a complete map installation, you must install a work area and a charging station on the map.

A work area is specified by virtual boundaries. Maximum 20 work areas and secondary areas can be installed on a map.

There are two types of work areas:

- A work area that has a charging station in it or connected to it with a transport path where the product operates automatically.
- A secondary area is a work area with no charging station and no transport path. The product must be moved manually to and from the work area.

A transport path is a specified path between the docking point in front of the charging station and a work area. The product can operate automatically in this path, but does not cut grass. A transport path can temporarily be enabled and disabled in the app.

Stay-out zones can be made if there are areas where the product must not operate. A stay-out zone is specified by virtual boundaries. Stay-out zones can temporarily be enabled and disabled in the app.

A maintenance point is a specified position where the product can be parked at. This can for example be used for a service point where maintenance of the product is done. The maintenance point is connected to the docking point with a path.

To install objects on the map, operate the product with the appDrive installation to add waypoints on the map. Refer to *To install objects on the map on page 20*.

3.10.8.1 To install objects on the map

The waypoints (A) are positions that makes the virtual boundaries and paths (B). The lines are straight between the waypoints. It is recommended to use as few waypoints as possible. For each work area and the related stay-out zones and transport path the total maximum number of waypoints are 800. Husqvarna recommends to add maximum 1000 waypoints for the complete installation of the map. To make smooth curves use several waypoints. Husqvarna recommends to set the minimum distance of 30 cm / 1 ft. between the waypoints. You can adjust the positions of the waypoints in the app after the installation of the map.

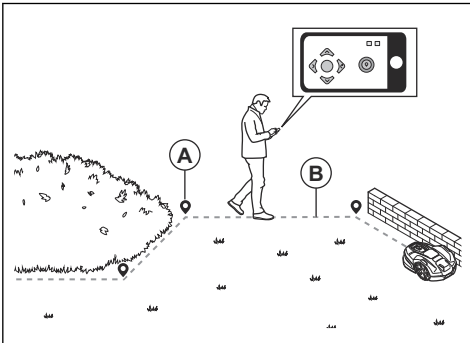

CAUTION: Do not lift and move the product between the waypoints when you install the map objects. Use appDrive for a correct installation.

Note: The position of the waypoint when you install a work area or a stay-out zone is in the front left corner of the product.

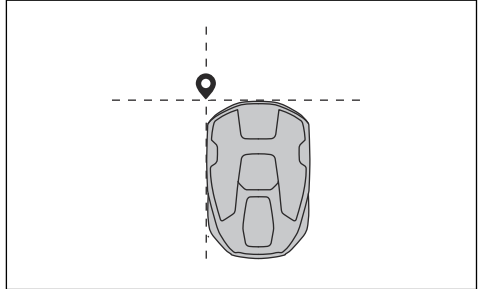

Note: The position of the waypoint when you install a transport path or a path to a maintenance point is in the middle of the product between the drive wheels.



- Make sure that you are near the product and connected to the product with the app with Bluetooth®.
- Make sure that the status is *EPOS™ confirmed* in the appDrive.

Note: A game controller with Bluetooth® can be used together with appDrive to operate the product.

- Select the object you want to install and use the buttons in the appDrive installation to operate the product.
- Use the **up** button (A) to move the product forward.
- Use the **down** button (B) to move the product rearward.
- Use the **left arrow** button (C) to rotate the product to the left.
- Use the **right arrow** button (D) to rotate the product to the right.

- Use the **center** button (E) as a joystick to move and rotate the product in any direction.
- Use the **waypoint** button (F) to add a waypoint in the map.

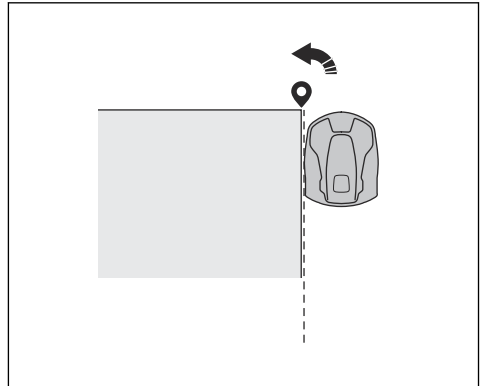
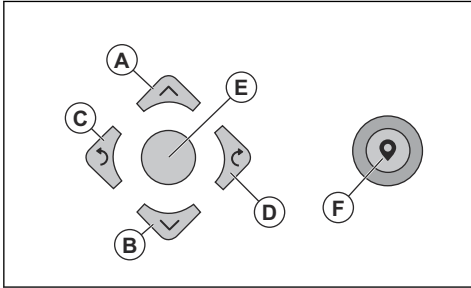

Note: Walk 2-3 m / 6.5-9.8 ft. behind the product when you operate the product with appDrive.

- Do not set waypoints that make a virtual boundary go across itself in the same work area.
- Save the work area to automatically connect the first and last waypoint with a virtual boundary.

To make a work area

Minimum 3 waypoints are necessary to make a work area.

- Operate the product clockwise around the boundary of the work area and set waypoints.

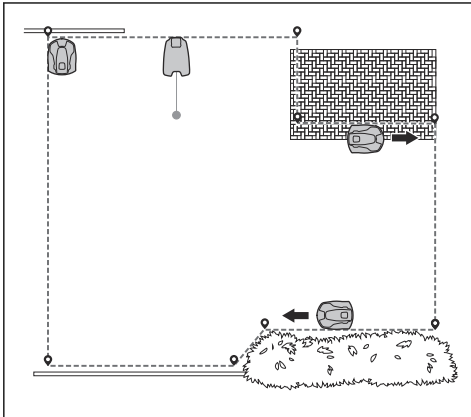

- Add the waypoint at the outer corner to install the virtual boundary around a corner.

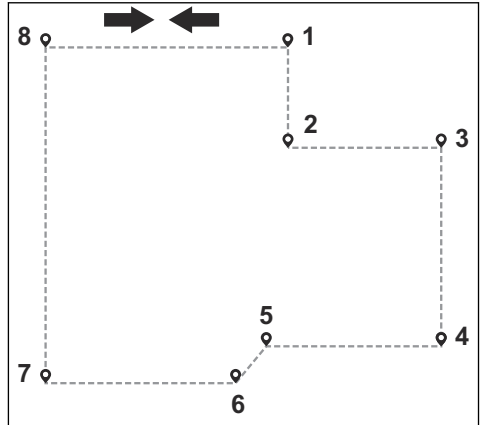

To make a stay-out zone

Minimum 3 waypoints are necessary to make a stay-out zone.

- Operate the product counterclockwise around the boundary of the stay-out zone.
- Do not set waypoints that make a virtual boundary go across itself in the same stay-out zone.
- Save the stay-out zone to automatically connect the first and last waypoint with a virtual boundary.

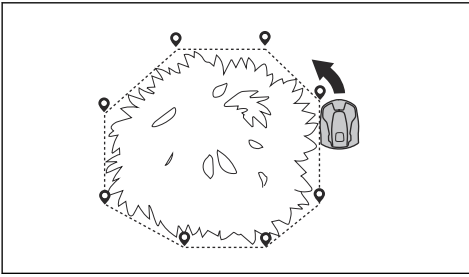

To make a transport path

- Operate the product and add waypoints on the map to install a transport path. Start in a work area minimum 1 m / 3.3 ft. from the virtual boundary.
- Install the transport path perpendicular to the virtual boundary of the work area.
- Do not install a transport path across a stay-out zone.
- Do not set waypoints that make the transport path go across the same transport path.
- Do not make sharp bends when you install the transport part. Husqvarna recommends to add more waypoints to make smoother curves.

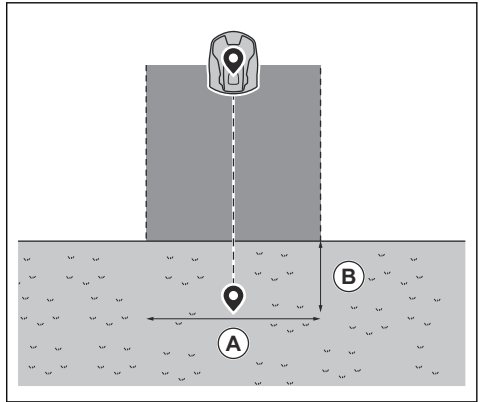

To make a maintenance point

- Operate the product and add waypoints on the map. Start to add waypoints at the position where you install the maintenance point. The first waypoint specifies the maintenance point.
- Do not make sharp bends when you install a transport part. Husqvarna recommends to add more waypoints to make smoother curves.

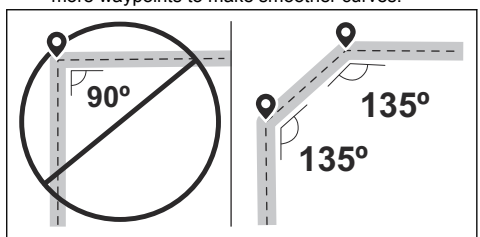
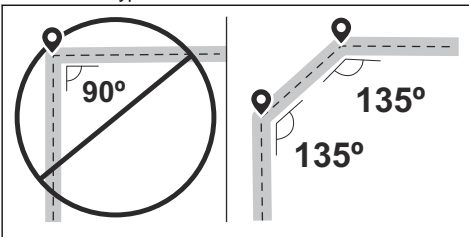

- Operate the product and add waypoints to connect the transport path to the docking point.
- Put the last waypoint on a transport path (A) in an angle of +/-45 degrees seen from the docking point.

- Operate the product and add waypoints to make a path to the charging station.
- Put the last waypoint on a transport path (A) in an angle of +/-45 degrees seen from the docking point.

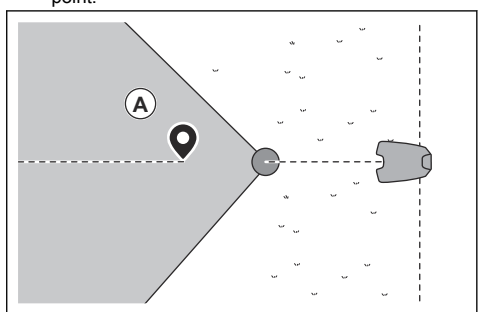
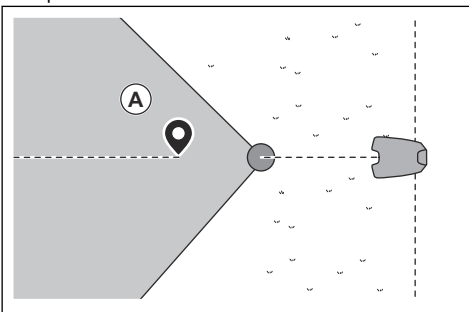

- Save the transport path to automatically connect the last waypoint to the docking point.
- Set the corridor width (A) for the transport path. The corridor width can be set to 2-5 m / 6.6-16.4 ft.

- Save the maintenance point to automatically connect the last waypoint to the docking point.

- Set the corridor width (A) for the maintenance point. The corridor width can be set to 2-5 m / 6.6-16.4 ft.

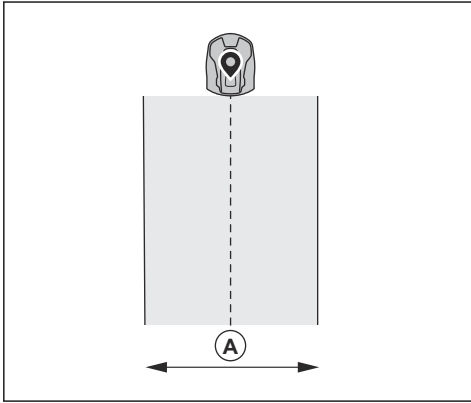

4 Installation with boundary wire

4.1 Introduction - Installation



WARNING: Read and understand the safety chapter before you install the product.



CAUTION: Use original spare parts and installation material.

Note: Refer to www.husqvarna.com for more information about installation.

4.2 Primary components for installation

The installation involves the following components:

- A robotic lawn mower that mows the lawn automatically.
- A charging station, which has 3 functions:
 - To send control signals along the boundary wire.
 - To send control signals along the guide wire so that the product can follow the guide wire to specific remote areas in the garden and can find its way back to the charging station.
 - To charge the product.
- A power supply, which is connected to the charging station and a 100-240V power outlet.
- Loop wire, which is laid around the work area and around objects and plants that the product must not run into. The loop wire is used both as boundary wire and guide wire.

4.3 To prepare for installation

Read the installation chapter before you start the installation. Prepare the installation carefully to make the product operate satisfactorily.

- Make a blueprint of the work area and include all obstacles. This makes it easier to examine where to put the charging station, the boundary wire and the guide wire.
- Make a mark on the blueprint where to put the charging station, the boundary wire and the guide wire.
- Make a mark on the blueprint where the guide wire connects to the boundary wire. Refer to *To install the guide wire on page 30*.
- Fill in holes in the lawn to make it level.



CAUTION: Holes with water in the lawn can cause damage to the product.

- For Automower® 305E/310E NERA, make sure that you have Wi-Fi coverage in the charging station to download new firmware. Refer to *Download firmware over the air FOTA (Firmware over the air) on page 38*. For Automower® 405XE/410XE NERA Wi-Fi or cellular technology is used for FOTA.
- For Automower® 305E/310E NERA, make sure that you have Wi-Fi coverage in the work area if you use the Automower® Connect app remotely. Refer to *To do a pairing operation with the Automower® Connect app on page 31*. For Automower® 405XE/410XE NERA Wi-Fi or cellular technology is used for Automower® Connect.

Note: We recommend you to have Wi-Fi coverage in the work area. If you have Wi-Fi coverage, you can control and make settings for the product remotely with the Automower® Connect app. The product automatically connects to Wi-Fi when it is in an area that has Wi-Fi coverage.

- Cut the grass and trim the edges before you install the product. Make sure that the grass is maximum 6 cm / 2.5 in.

Note: The first weeks after installation the sound level when the product cuts the grass can be higher than usual. The sound level decreases after some time.

4.4 Before the installation of the wires

You can select to attach the wires with stakes or bury them. You can use the 2 procedures for the same work area.



CAUTION: If you use a dethatcher in the work area, bury the boundary wire and the guide wire to prevent them from damage.

4.4.1 To examine where to put the charging station

- Keep a minimum 3 m / 10 ft. of free space in front of the charging station. Refer to *To examine where to put the guide wire on page 28*.
- Keep a minimum of 150 cm / 60 in. of free space to the right and left of the center of the charging station.

- Put the charging station near a power outlet.
- Put the charging station on a level surface.
- The baseplate of the charging station must not be bent.

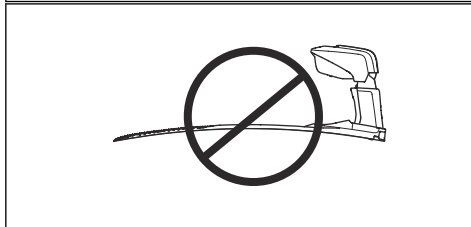
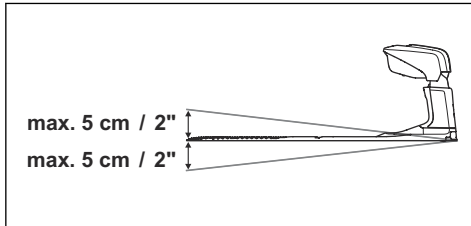

- If the work area has two parts separated with a steep slope, we recommend to put the charging station in the lower section.
- Put the charging station in an area with protection from the sun.
- If the charging station is installed on an island, make sure to connect the guide wire to the island.

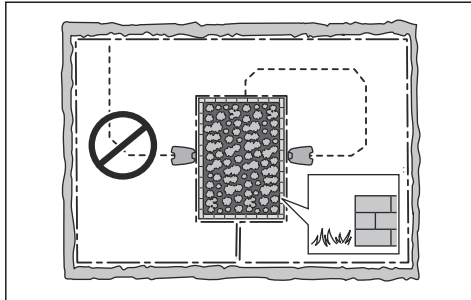

4.4.2 To examine where to put the power supply



CAUTION: Make sure that the blades on the product do not cut the low-voltage cable.



CAUTION: Do not put the low-voltage cable in a coil or below the charging station plate. The coil causes interference with the signal from the charging station.

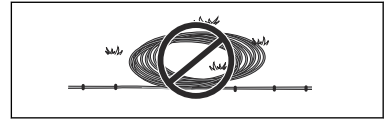

- Put the power supply in an area with a roof and protection from the sun and rain.
- Put the power supply in an area with good airflow.
- Use a residual-current device (RCD) with a tripping current of maximum 30 mA when you connect the power supply to the power outlet.

Low-voltage cables of different lengths are available as accessories.

4.4.3 To examine where to put the boundary wire



CAUTION: There must be a barrier of minimum 15 cm / 6 in. in height between the boundary wire and water bodies, slopes, precipices or public roads. This will prevent damage to the product.



CAUTION: Do not let the product operate on gravel.



CAUTION: Do not make sharp bends when you install the boundary wire.



CAUTION: For a careful operation without noise, isolate all obstacles such as trees, roots and stones.

The boundary wire must be put as a loop around the work area. For good cutting results with EdgeCut, it is necessary to install the boundary wire at the correct distances to obstacles. The product only cuts with EdgeCut by the boundary wire. To use EdgeCut around trees and obstacles, make islands around them. Refer to *To make an island on page 27*. Sensors in the product sense when the product goes near the boundary wire, and the product selects a different direction. All parts of the work area must be maximum 35 m / 115 ft. from the boundary wire.

- Put the boundary wire around the work area (A). Adapt the distance between the boundary wire and obstacles.

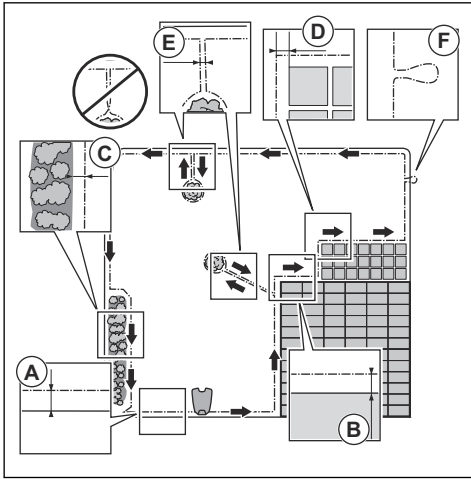

a) Put the boundary wire 35 cm / 14 in. (B) from an obstacle that is more than 3 cm / 1.2 in. high.

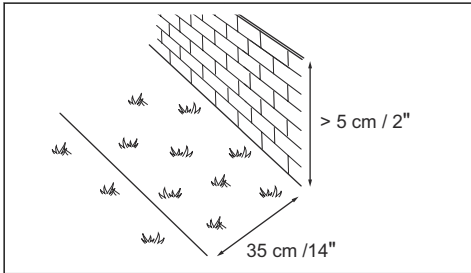

b) Put the boundary wire 30 cm / 12 in. (C) from an obstacle that is 1-3 cm / 0.4-1.2 in. high.

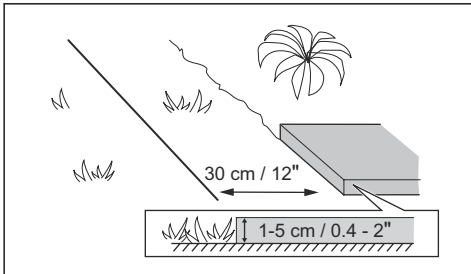

c) Put the boundary wire 10 cm / 4 in. (D) from an obstacle that is less than 1 cm / 0.4 in. high.

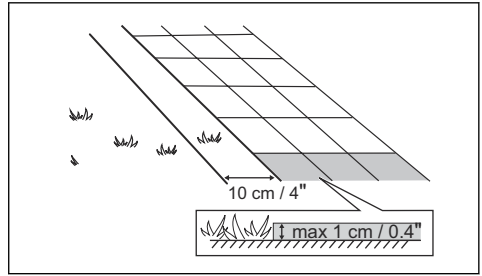

- If you have a paving stone path that is in level with the lawn, put the boundary wire below the paving stone.
- If you make an island, put the boundary wire that goes to and from the island near together (E). Refer to *To make an island on page 27*.
- Make an eyelet (F) where the guide wire is to be connected to the boundary wire. This makes the connection easier between the guide wire and the boundary wire. Make the eyelet with approximately 20 cm / 8 in. of the boundary wire.

4.4.3.1 To put the boundary wire in a slope

Slopes that are too steep must be isolated with the boundary wire. The gradient (%) is calculated as the vertical height divided by the horizontal distance.

Example:

- $10 \text{ cm} / 100 \text{ cm} = 10\%$.
- $\text{in} / \text{in} = 10\%$.

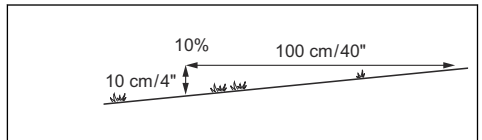

- For slopes that are too steep inside the work area, isolate the slope with boundary wire.
- For slopes steeper than 20% along the outer edge of the lawn, put the boundary wire 20 cm / 8 in. (A) from the edge.
- For slopes adjacent to a public road, put a barrier of minimum 15 cm / 6 in. along the outer edge of the slope. You can use a wall or a fence as a barrier.

4.4.3.2 Passages

A passage is a section that has boundary wire on each side and that connects 2 parts of the work area. The distance between the boundary wire on each side in the passage must be a minimum of 60 cm / 24 in.

Note: If a passage is less than 2 m / 6.5 ft. wide, install a guide wire through the passage.

The recommended minimum distance between the guide wire and the boundary wire is 30 cm / 12 in. The product always runs to the left of the guide wire as seen facing the charging station. It is recommended to have as much free area as possible to the left of the guide wire (A).

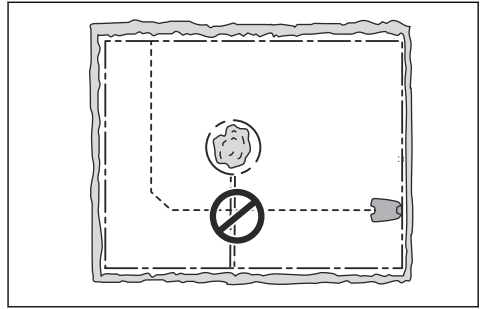
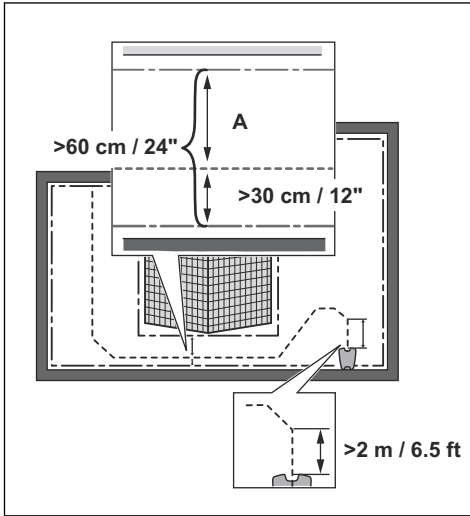

To make an island, isolate areas in the work area with the boundary wire. We recommend to isolate all stable objects in the work area.

Some obstacles are resistant to a collision, for example, trees or bushes that are more than 15 cm / 5.9 in. in height. The product will collide with the obstacle and then select a new direction.

- Put the boundary wire to and around the obstacle to make an island.
- Put the 2 sections of boundary wire to and from the island close together. This will make the product run across the wire.
- Put the 2 sections of boundary wire in the same stake.

4.4.3.3 To make an island



CAUTION: Do not put the boundary wires across each other. The sections of boundary wire must be parallel.



CAUTION: Do not put the guide wire across the boundary wire.



CAUTION: Isolate or remove obstacles that are less than 15 cm / 5.9 in. in height. Isolate or remove obstacles that slope slightly, for example, stones, trees or roots. This will prevent damage to the blades of the product.

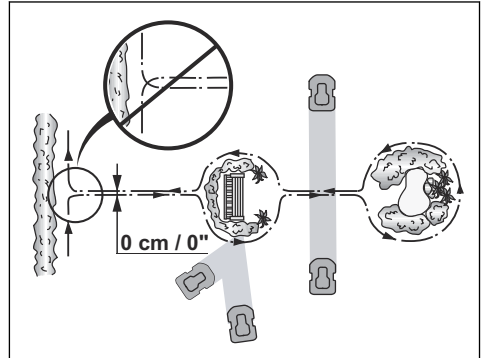

4.4.3.4 To make a secondary area

Make a secondary area (B) if the work area has 2 areas that are not connected with a passage. The work area with the charging station is the main area (A).

Note: The product must be manually moved between the main area and the secondary area.

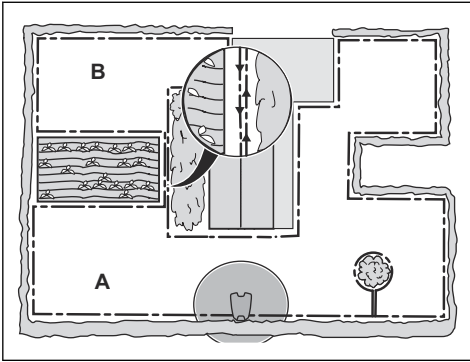

- Put the boundary wire around the secondary area (B) to make an island. Refer to *To make an island on page 27*.

Note: The boundary wire must be put as 1 loop around all of the work area (A + B).

Note: When the product cuts grass in the secondary area, the *Secondary area mode* must be selected. Refer to *Secondary area on page 39*.

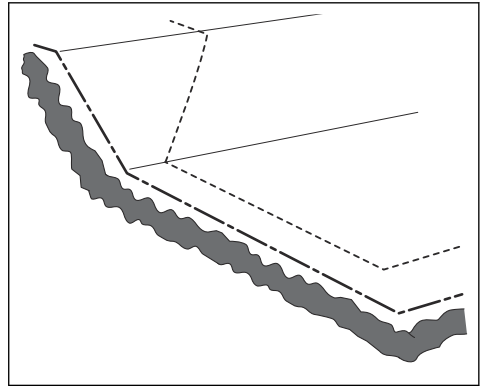

4.4.5 Work area examples

- If the charging station is put in a small area (A), make sure that the distance to the boundary wire is at a minimum 3 m / 10 ft. in front of the charging station.
- If the work area has a passage (B) with no guide wire installed, the recommended minimum distance between the boundary wires is 2 m / 6.5 ft. With a guide wire installed through the passage, the recommended minimum distance between the boundary wires is 60 cm / 24 in.
- If the work area has areas which are connected by a narrow passage (B), you can set the product to first follow and then leave the guide wire after a certain distance (C). The settings can be changed in *Lawn coverage on page 35*.
- Use the GPS Assisted Navigation that helps the product select the most optimal operation. Refer to *GPS assisted navigation on page 35*.
- If the work area includes a secondary area (D), refer to *To make a secondary area on page 27*. Put the product in the secondary area and select *Secondary area mode*.

4.4.4 To examine where to put the guide wire

- Put the guide wire in a line at a minimum of 2 m / 6.5 ft. in front of the charging station.
- Make as much free area as possible to the left of the guide wire when facing the charging station. Refer to *To install the guide wire on page 30*.
- Put the guide wire minimum 30 cm / 12 in. from the boundary wire.
- Do not make sharp bends when you install the guide wire.

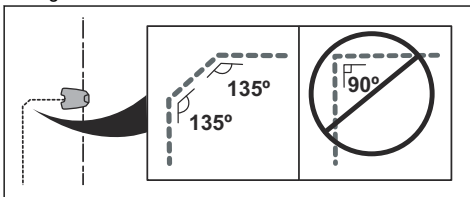

- If the work area has a slope, put the guide wire diagonally across the slope.

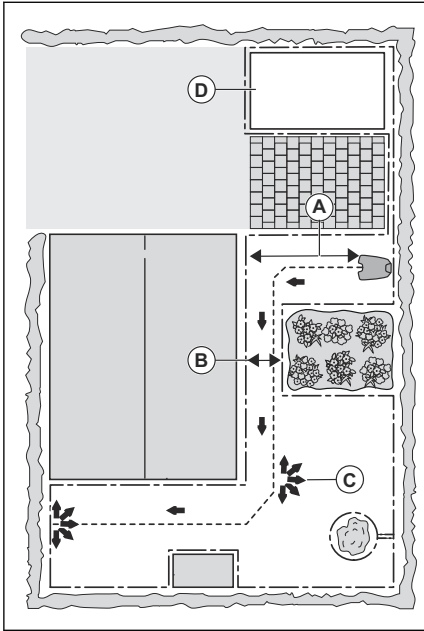

When connecting the power supply, only use a power outlet that is connected to an residual-current (RCD) device.

1. Read and understand the instructions about the charging station. Refer to *To examine where to put the charging station on page 24*.
2. Put the charging station in the selected area.

Note: Do not attach the charging station to the ground with the screws until the guide wire is installed. Refer to *To install the guide wire on page 30*.

3. Open the hatch on the front of the charging station.
4. Attach the top of the charging station.

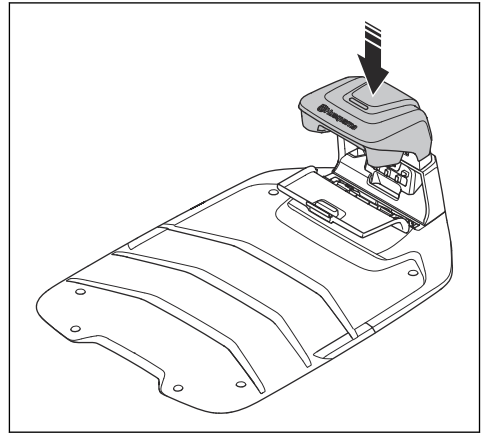

5. Lift and tilt the top of the charging station.
6. Put the grommet with the cables into position.
7. Connect the cable to the charging station.

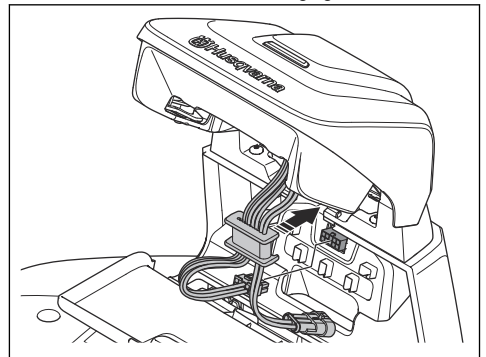

8. Connect the low-voltage cable to the charging station.
9. Close the hatch on the front of the charging station.

4.5 Installation of the product

4.5.1 Installation tools

- Hammer/plastic mallet: To simplify putting the stakes into the ground.
- Edge cutter/straight spade: To bury the boundary wire.
- Combination pliers: For cutting the boundary wire and pressing the connectors together.
- Adjustable plier: For pressing the couplers together.

4.5.2 To install the charging station



CAUTION: Do not make new holes in the charging station plate.



CAUTION: Do not put your feet on the baseplate of the charging station.



WARNING: Make sure that the plugs of the low-voltage cable and the power supply unit are clean and dry before you connect them.

- Put the power supply at a minimum height of 30 cm / 12 in.

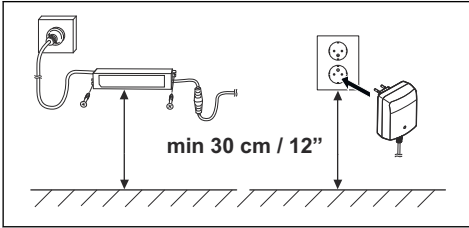

- Connect the power supply cable to a 100-240V power outlet.

Note: The product can be put in the charging station to charge while you install the boundary wire.

- Put the low-voltage cable in the ground with stakes or bury the cable. Refer to *To put the wire or the cable into position with stakes on page 31* or *To bury the wire or the cable on page 31*.
- Connect the wires to the charging station after the installation of boundary wire and guide wire is complete. Refer to *To install the boundary wire on page 30* and *To install the guide wire on page 30*.
- Attach the charging station to the ground with the supplied screws after the guide wire is installed. Refer to *To install the guide wire on page 30*.

4.5.3 To charge the product

- Put the product in the charging station.

Note: The product starts to charge automatically when the product is in the charging station.

4.5.4 To install the boundary wire



CAUTION: Do not put remaining wire in a coil. The coil causes interference with the product.

- Put the boundary wire around all of the work area. Start and complete the installation behind the charging station.
- Open the connector and put the boundary wire in the connector.

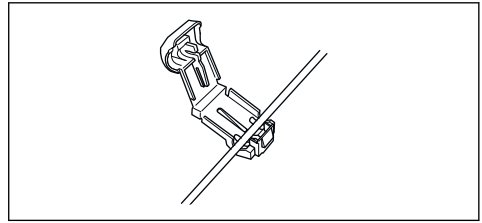

- Close the connector with a pair of pliers.

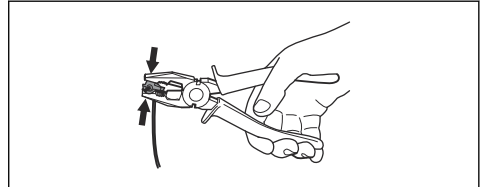

- Cut the boundary wire 1-2 cm / 0.4-0.8 in. above each connector.
- Push the right connector onto the metal pin on the charging station with the mark "AR".
- Push the left connector onto the metal pin on the charging station with the mark "AL".

4.5.5 To install the guide wire



CAUTION: Twinned cables, or a screw terminal block that is insulated with insulation tape are not satisfactory splices. Soil moisture will cause the wire to oxidize and after a time result in a broken circuit.

- Open the connector and put the wire in the connector.
- Close the connector with a pair of pliers.
- Cut the guide wire 1-2 cm / 0.4-0.8 in. above the connector.
- Push the connector onto the metal pin on the charging station with the mark "G1/G2/G3".

Note: For Automower® 305E/310E NERA 2 guide wires can be installed and for Automower® 405XE/410XE NERA 3 guide wires can be installed.

- Disconnect the charging station from the power outlet.
- Put the guide wire from the charging station to the point where you want to connect it to the boundary wire.
- Attach the guide wire to the ground with stakes or bury the guide wire in the ground. Refer to *To put the wire or the cable into position with stakes on page 31* or *To bury the wire or the cable on page 31*.

8. Put the end of the guide wire at the eyelet on the boundary wire.
9. Cut the boundary wire with a pair of wire cutters.
10. Connect the guide wire to the boundary wire with a coupler.

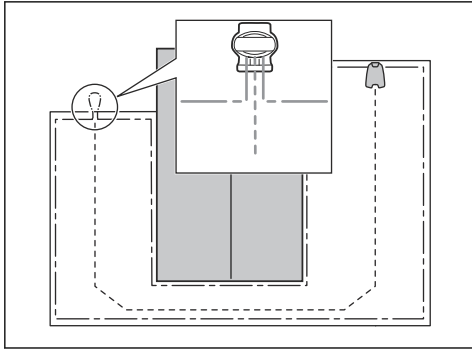

- a) Put the 2 ends of the boundary wire and the end of the guide wire into the coupler.

Note: Make sure that you can see the ends of the wires through the transparent area of the coupler.

- b) Push down the cover on the coupler with adjustable pliers to attach the wires in the coupler.

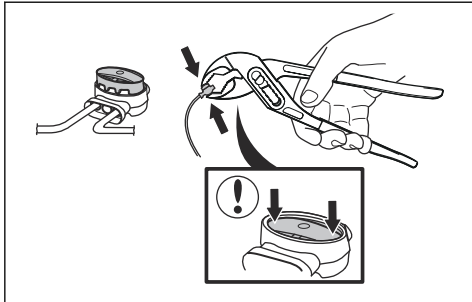

11. Connect the charging station to the power outlet.

4.5.6 To put the wire or the cable into position with stakes



CAUTION: Make sure that the stakes hold the wire or the cable against the ground.



CAUTION: Cutting the grass too low right after installation can damage the wire or the cable insulation. Damage to the

insulation may not cause disruptions until several weeks or months later.

1. Put the wire or the cable on the ground.
2. Put the stakes at a maximum of 75 cm / 30 in. distance from each other.
3. Attach the stakes to the ground with a hammer or a plastic mallet.

Note: The wire or the cable is overgrown with grass and not visible after a few weeks.

4.5.7 To bury the wire or the cable

- Cut a groove in the ground with an edge cutter or a straight shovel.
- Put the wire or the cable 1-20 cm / 0.4-8 in. into the ground.

4.5.8 To do a visual check of the charging station

1. Make sure that the indicator LED lamp on the charging station has a green light. Refer to *LED indicator of the charging station on page 52* for information about the LED indicator.

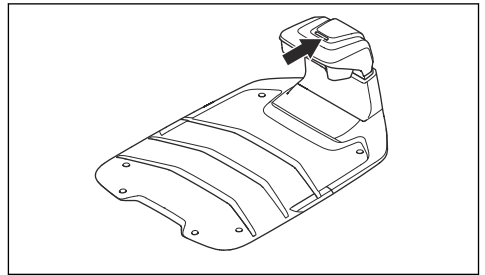

2. If the indicator LED lamp does not have a green light, do a check of the installation. Refer to *LED indicator of the charging station on page 52* and *To install the charging station on page 29*.

4.5.9 To do a pairing operation with the Automower® Connect app

1. Download the Automower® Connect app on your mobile device.
2. Sign up for a Husqvarna account in the Automower® Connect app and follow the instructions.
3. Enter the factory PIN code 1234 on the product.
4. Use the jog wheel on the product to select the Bluetooth® menu to enable the pairing operation mode.
5. Select *My mowers* in the Automower® Connect app and add your product.

6. Follow instructions in the Automower® Connect app.
-

Note: Husqvarna recommends to change the factory PIN code to a new PIN code in the app.

5 Settings

This chapter gives information about the settings for the product that you can make in the Automower® Connect app. All setting for the product are available in Automower® Connect. Some settings can also be made in Automower® Access, refer to *Menu structure overview in Automower® Access on page 10*. The product has factory settings but the settings can be adapted for each work area.

5.1 Schedule



In *Schedule* you can change the schedule settings for the product.

The *Scheduler Tool* adapts the schedule to the size of your work area. The *Schedule* function controls which hours the product operates. When the product does not operate, it is parked in the charging station. You can see which hours and days the product operates in the schedule overview in the app.

5.1.1 To set the schedule for systematic mowing

- Set the schedule to let the product operate for as long time as possible.

Note: After the product has cut the full work area, it goes back to the charging station. When the next session starts, the product cuts the full work area again.

Note: If the product has not cut the full work area before the session ends, it goes back to the charging station. When the next session starts, the product continues to cut from where it stopped.

- To cut a work area 2 times a day, you can set 2 different schedules. Set the schedule for the product to have sufficient time to cut the complete work area.
- With 2 or more parallel schedules, the product starts to cut where it has not cut for the longest time.
- Make sure that the product completes to cut each work area in less than 24 hours. If the product must cut a work area for more than 24 hours, divide the work area into smaller work areas.

5.1.2 To set the schedule for irregular mowing

The product operates the complete scheduled time with irregular mowing.

- Decrease the scheduled time to prevent wear on the grass.
- If the cutting result is not satisfactory, increase the scheduled time. Refer to *Schedule on page 33*.
- With 2 or more parallel schedules in different work areas, the product first starts to cut 1 work area. After each charging of the product, the product starts to cut another work area.

5.2 Cutting height



5.2.1 Adjust the cutting height

The cutting height can be adjusted from 2 cm / 0.8 in. to 5.5 cm / 2.2 in.



CAUTION: The first weeks after a new installation, the cutting height must be set to 5.5 cm / 2.2 in. to prevent damage to the loop wire. The cutting height can then be lowered each week.

5.2.2 TargetHeight

Use the TargetHeight function to lower the cutting height from the maximum cutting height to the specified cutting height gradually during 10 days. If you change the cutting height manually during this time it will disable the TargetHeight function.

5.3 Pattern



The settings for pattern can be set for each work area with an EPOS installation. You can do these settings:

- Set the pattern for how the product operates.
- For some patterns you can set the direction of the pattern.
- For a satisfactory edge cutting result, use for example the checkerboard or triangle pattern. These mowing patterns cuts the edges in both directions.

- For slopes, set the alternating mowing pattern at a 45 degree angle to the slope.
- For some patterns you can set the type of the *Border mowing*. With *Fixed border mowing* the product always operates in the same paths to keep a sharp border around the work area. With *Variable border mowing*, the product operates in different paths to decrease the risk of track marks along the virtual boundary.

Husqvarna recommends to use systematic pattern on large and open work areas. If you use systematic pattern on a work area with obstacles, make stay-out zones around obstacles and use a pattern with many directions for the best possible cutting result.

Husqvarna recommends to use irregular pattern if the work area is complex and has many obstacles or includes steep slopes.

5.4 Operation



In *Operation* you can change the operation settings of the product.

5.4.1 Spiral cutting

Spiral cutting is only applicable for work areas with irregular pattern. If the product enters an area where it senses the grass is longer than average, it can change the movement pattern to *Spiral cutting*. This means that the product mows in a spiral pattern to faster cut the area with longer grass. It is possible to set the intensity of the *Spiral cutting*. *Very low / Low* intensity means that *Spiral cutting* begins less often. *High / Very high* intensity means that *Spiral cutting* begins more often.

Note: *Spiral Cutting* does not start in slopes steeper than 17%.

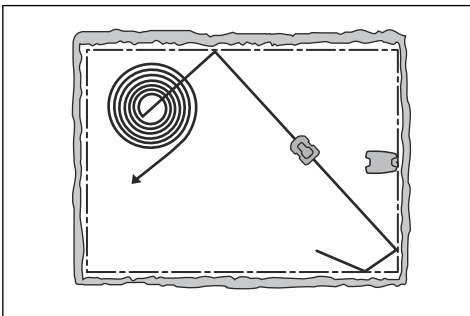

5.4.2 Object avoidance

Object avoidance is only available for Automower® 405XE/410XE NERA.

The product senses objects on the lawn that is higher than the grass with the *Object avoidance* function enabled. When the product senses an object on the lawn, the product turns and continues to cut in a different direction. You can disable the *Object avoidance* function if it is unsatisfactory for your work area.

Note: *Object avoidance* can cause that the grass is not cut around objects. The sensors can also sense high grass or flowers in the work area as objects.

5.4.3 Weather timer

Weather timer automatically adjust the cutting time to the growth of the grass. The product is not permitted to operate more than the schedule settings.

Note: When using *Weather timer*, it is recommended to make as much operating time as possible available for *Weather timer*. Do not restrict the schedule more than necessary.

The first operation of the day is set by the schedule settings. The product always complete 1 mowing cycle, and then *Weather timer* selects if the product will continue to operate or not.

Note: *Weather timer* is reset if the product does not operate for more than 50 hours, or if a *Reset of all user settings* is done. *Weather timer* is not changed if a *Reset of schedule settings* is done.

5.4.4 ECO mode

ECO mode disables the signal in the boundary wire, guide wire and the charging station, when the product is parked or is charging. The LED indicator of the charging station flashes green when the loop signal is disabled.

Note: Use *ECO mode* to save energy and to prevent interference with other equipment, for example hearing loops or garage doors.

Note: To start the product manually in the work area you must first enable the loop signal.

5.4.4.1 To enable the loop signal

1. Set the product to ON.
2. Put the product in the charging station.
3. Push the **STOP** button.

4. Wait 2 seconds and then remove the product from the charging station.
5. Make sure that the LED indicator of the charging station is solid green.
6. Put the product where you want it to start to cut.

5.4.5 EdgeCut

The product has EdgeCut which makes the product cut the edges of your lawn. You can disable EdgeCut in the app during season with low grass growth.

5.5 Installation settings



In *Installation* you can change the settings for an installation with boundary wire.

5.5.1 To find the charging station

The product can be set to search for the charging station in 3 methods:

- *Charging station signal*
- *Follow boundary wire*
- *Follow guide wire*

The factory setting is set to use the 3 search methods at the same time. Use the factory setting to find the charging station as fast as possible and to keep the risk of tracks on the lawn to a minimum. The product always starts to search for the *Charging station signal*. After a specified time interval, it also uses *Follow guide* and *Follow boundary wire*.

Causes why the product cannot follow the wire:

- Obstacles near the wire have not been isolated.
- The charging station, the boundary wire or the guide wire are not installed according to the instructions in *To install the charging station on page 29*, *To install the boundary wire on page 30* and in *To install the guide wire on page 30*.

5.5.1.1 Charging station signal

For some installations it is necessary to decrease the signal of the charging station. For example when the charging station is put near an obstacle, such as a bush or a wall. The product finds the charging station signal on the other side of the obstacle and tries to find the charging station, but the object prevents it to go to the charging station. You can set the charging station signal to *min*, *avg* or *max*.

Note: Husqvarna recommends to set the charging station signal to *max*. It is usually better to move the charging station, than to decrease the range of the charging station signal.

5.5.1.2 Follow guide wire and boundary wire

The time interval can be set for when the product starts to follow the boundary wire and guide wire to find the charging station.

5.5.2 Lawn coverage

5.5.2.1 GPS assisted navigation

The product has *GPS Assisted Navigation* that helps the product to select the most optimal operation. This function is enabled from the factory. If you want to do manual settings for your lawn, disable the *GPS Assisted Navigation* and make settings for *Area 1-5*. Disable the *GPS Assisted Navigation* if you want to use the *Systematic Passage Mowing* function and make settings for *Area 1-5*. Refer to *Settings for Area 1-5 on page 35*.

5.5.2.2 Settings for Area 1-5

Use this function if the work area includes remote parts that are connected with narrow passages to keep a satisfactorily cut work area. The *Lawn Coverage* function is used to cut remote parts of the work area. The *Systematic Passage Mowing* function is used to cut in narrow passages. A guide wire must be installed to use these functions. You can set a maximum of 5 remote areas where the product starts to cut.

The *Systematic Passage Mowing* function is applicable for narrow passages of 60 cm - 1.5 m / 23 in. - 4.9 ft. width. The product moves in a pattern to cut the full passage width. The product starts the *Systematic Passage Mowing* at the set distance from the charging station. When the product is at the end of the narrow passage, the product continues to cut the work area as usual.

You can set the product to follow the guide wire to the set specified distance before it starts to cut.

Area A, approximately 50%

Area B, approximately 30%

Area C, approximately 20%

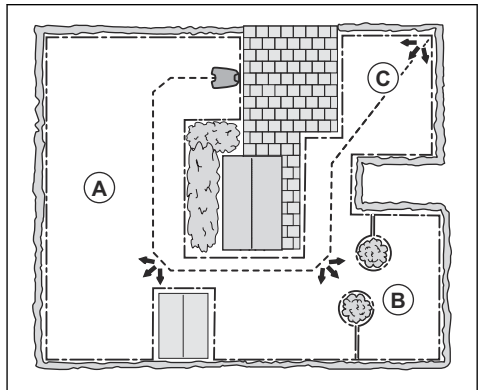

Each area can be enabled or disabled. Use the *Test* function to measure the distance from the charging station to where the product must start to cut. Refer to *To measure the distance from the charging station on page 36*.

The default settings lets the product follow the guide wire 300 m / 980 ft. in 20% of the times it moves out from the charging station. If the guide wire is less than 300 m / 980 ft. the product will follow it to the point where the guide wire is connected to the boundary wire.

5.5.2.3 To measure the distance from the charging station

The product follows the guide wire to measure the distance to the charging station.

1. Put the product in the charging station.
2. Select *Test: Area 1 setup* or *Test: Area 2 setup* to measure the distance.
3. Push the **STOP** button to show the distance in the app.

5.5.3 Corridor width

The boundary wire corridor is the area adjacent to the boundary wire. The product uses the corridors to find the charging station. The corridor width is adjusted automatically. If it is necessary to adjust the corridor width manually for the product to operate satisfactorily, you can set the corridor width between 1-9.

5.5.4 Reversing distance

The reversing distance makes the product move in reverse for a set distance, before the product starts to cut the lawn.

5.5.5 Drive Past Wire function

The front of the product always moves past the boundary wire by a specified distance. Then the product moves rearward and changes direction. The factory setting is 32 cm / 13 in. You can select a distance of 25-40 cm / 10-16 in.

Note: If you change the distance for *Drive Past Wire*, the distance will change along the boundary wire in all parts of the work area.

5.6 Accessories



In *Accessories* you can change the settings of the product accessories.

5.6.1 Headlights

Headlights is only available for Automower® 405XE/ 410XE NERA.

There are 4 different headlight settings that control when the headlights are on:

- *Always on*
- *Evening only (19:00-00:00)*
- *Evening and night (19:00-07:00)*
- *Always off*

The default setting is *Always on*. The headlights can be set to flash if there is an error.

5.6.2 To avoid collisions with the Automower® house

When this option is enabled, the wear on the product and the Automower® house is reduced, but it can result in more uncut grass around the charging station.

5.7 General



In the *General* menu you can set the time and date, or reset to factory settings.

This menu is only available when your mobile device is connected to the product with Bluetooth®.

5.7.1 Time & date

The time and date can be changed manually, or by using the time and date from the mobile device.

5.7.2 Reset to factory settings

The user settings can be reset to factory settings.

Note: *PIN code, Loop signal, Messages and Date & Time* will not be reset.

5.8 Security



The security settings controls the PIN code, the GeoFence and other security functions. The correct PIN-code must be entered to get access to the *Security* menu.

This menu is only available when your mobile device is connected to the product with Bluetooth®.

5.8.1 New loop signal

The loop signal is randomly selected to create a unique link between the product and the charging station. In rare cases, there may be a need to generate a new signal, for instance if 2 adjacent installations have a very similar signal.

5.8.2 Change PIN code

You can change the PIN code. Make a note of the new PIN code in Memo. Refer to *Introduction on page 6*.

5.8.3 Theft protection

In the *Theft protection* menu it is possible to set the alarm duration and also what events should trigger the alarm. The factory setting is to require PIN code and the alarm duration is 1 min.

5.8.3.1 Require PIN code

This function means that the product cannot be operated or controlled after the **STOP** button has been pushed without first entering the correct PIN code. If the incorrect PIN code is entered 5 times, the product is locked for a time. The lock is extended for each new incorrect try.

5.8.3.2 Alarm duration

There is a possibility to set how long the alarm signal should last. A setting between 1 and 10 minutes is possible.

5.8.3.3 STOP button pressed

If the alarm "*STOP button pressed*" is enabled, the alarm goes off if someone presses the **STOP** button and the PIN code is not entered within 30 seconds.

5.8.3.4 Carried away

If the alarm *Carried away* is enabled, the product senses unexpected motions, and the alarm goes off.

5.8.4 GeoFence

GeoFence is a GPS-based theft protection that makes a virtual fence for the product. If the product is more than a set distance away from the center position the product will be disabled and an alarm will start. The center position sets to the current position of the product when GeoFence is enabled. The PIN code is necessary to stop the alarm and to start the product again. The GeoFence is only enabled when the product is set to ON.

5.9 Automower® Connect



In *Automower® Connect* you can enable or disable the Automower® Connect function. You can connect the

product to a Wi-Fi network. You can also see the signal strength and connectivity status.

This menu is only available when your mobile device is connected to the product with Bluetooth®.

5.10 Messages

In this menu the previous fault and information messages can be found. For some of the messages, there are tips and advice to help to rectify the fault.

If the product is disrupted in any way, for example it is trapped or the battery is low, a message is saved relating to the disruption and the time it happened.

If the same message is repeated several times, this may indicate that an adjustment to the installation or the product is required. Refer to *Introduction - Installation on page 12*.

5.11 Automower® Intelligent Mapping (AIM)

Automower® Intelligent Mapping (AIM) is available in the Automower® Connect app. The technology uses different sensors, GPS included, in the product. The precision of the map is approximately 1 m / 3.3 ft.

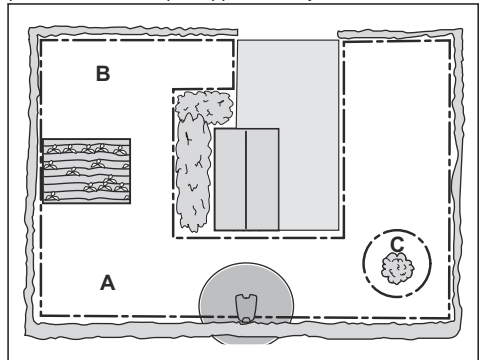

Some of the functions with AIM are:

- It shows a map of the lawn in the Automower® Connect app with charging station, boundary wire, guide wire and islands.
- You can make work areas (A) and (B) in the installation where you can set a schedule and cutting height for each work area. This is only available for Automower® 405XE/410XE NERA.
- You can make stay-out zones (C) in which the product cannot enter and cut grass. This is only available for Automower® 405XE/410XE NERA.

Note: With the AIM function you can set work areas and stay-out zones with a precision of approximately 1 m / 3.3 ft.

The data collection for the AIM map starts automatically. The product collects data while it operates and the map is completed in 1-2 weeks. Remove temporary obstacles on the lawn when the product operates and collects data. If you change the installation of the wires or charging station, you must do a new map. Read more about AIM in the Automower® Connect app.

5.12 Download firmware over the air FOTA (Firmware over the air)

The product has a function that automatically downloads new firmware. When a new firmware is available, a notification shows in the app where you can select to install the new firmware. The LED indicator of the product pulsates when the firmware update is ongoing. If the product does not use cellular connectivity, it downloads new firmware when it is parked in the charging station. The product must have Wi-Fi coverage in the charging station to download new firmware.

5.13 Mowing profiles

You can save different sets of settings in the *Mowing profiles*. Use this function when you use one product for more than one location or to have different settings on the same location. In the *Mowing profiles* the product settings, map objects and their settings are saved.

5.14 To reinstall the charging station on the map

Reinstall the charging station on the map if you move or replace the charging station. You can also reinstall it if the product cannot dock or connect to the charging station.

1. Select *Map objects > Charging station* in the app.
2. Select *Reinstall charging station* and follow the instructions.

Note: Other devices with Bluetooth® enabled can cause interference with the pairing operation. Disable Bluetooth® on the other devices if it causes interference with the pairing operation.

6 Operation

The most frequently used operation settings are included in the Automower® Access, refer to *Automower® Access on page 6*. All operating modes are available in the Automower® Connect app.

6.1 To set the product to ON



WARNING: Read and understand the safety chapter before you use the product.

- Push the **jog wheel** for 3 seconds.
- Use the **jog wheel** to enter the PIN code.

6.2 To start the product

1. Push the **STOP** button.
2. Use the **jog wheel** to enter the PIN code.
3. Use the **jog wheel** to select the operating mode. Refer to *Operating modes - Start on page 39*.
4. Push the **START** button.

Note: The first weeks after installation the perceived sound level when cutting the grass may be higher than expected. When the product has cut the grass for some time, the perceived sound level is much lower.

6.2.1 Operating modes - Start

6.2.1.1 Main area

Use the operating mode *Main area* for the product to cut and charge automatically.

6.2.1.2 Secondary area

Use *Secondary area* operating mode to cut secondary areas. You must move the product manually between the main area and the secondary area. The product cuts for a selected period of time or until the battery is empty.

Note: You must put the product manually in the charging station to charge the product when it is in a secondary area. The product will move out from the charging station and stop when the battery is charged. You must select an operating mode to start the product.

Note: If you will cut the main area after the battery is charged, set the product to *Main area* mode before you put the product in the charging station.

6.2.1.3 Override schedule

Use the operating mode *Override schedule* to temporarily override the *Schedule* settings for *24h* or *3 days*.

6.3 To park the product

1. Push the **STOP** button.
2. Use the **jog wheel** to enter the PIN code.
3. Use the **jog wheel** to select the park mode. Refer to *Operating modes - Park on page 39*.
4. Push the **START** button.

6.3.1 Operating modes - Park

6.3.1.1 Park until further notice

Use the operating mode *Park until further notice* for the product to go back to the charging station. The product will stay in the charging station until you select a new operating mode.

6.3.1.2 Start on next schedule

Use the operating mode *Start on next schedule* for the product to go back to the charging station. The product will stay in the charging station until the next *Schedule* setting.

6.3.1.3 Select duration

The product goes back to the charging station and stays for the selected park duration. Use the operation selection to temporary stop an ongoing mowing cycle and let the product to stay in the charging station.

6.3.1.4 Park at maintenance point (EPOS™ installation only)

You can park the product at the maintenance point to do maintenance on the product. The product is parked at the maintenance point until you select a new operation mode.

6.4 To stop the product

1. Push the **STOP** button to make the product and the cutting motor stop.

6.5 To set the product to OFF

1. Push the **STOP** button to stop the product.
2. Enter the PIN code if it is necessary.
3. Push the **jog wheel** for 3 seconds to set the product to OFF. You can also use the jog wheel to select *Power off* in the menu in the display.
4. Make sure that the LED indicator on the jog wheel is not lit.

6.6 To charge the battery

When the product is new or after long-term storage, the battery can be empty. Charge the battery before you start the product. In the *Main area* mode, the product cuts and charges automatically.

1. Set the product to ON.
2. Put the product into the charging station until the charging plates touch the contact plates.
3. Do a check that the product charges in the display of the product or in the Automower® Connect app.

7 Maintenance

7.1 Introduction - maintenance



WARNING: Set the product to OFF before you do maintenance on the product.



WARNING: Use protective gloves.

For better operation and lifetime of the product, make sure to clean the product regularly and replace worn parts.

When the product is new, examine the blade discs and blades each week. If the wear is low, you can increase the interval for the next time you examine the blade discs and blades. Examine the blade discs and the blades more regularly if there is much wear.

It is important that the blade disc rotates easily and that the edges of the blades are not damaged. The usual lifetime of the blades are 3-6 weeks for the main blade disc and 9-12 weeks for the EdgeCut blade disc. The conditions that follow can increase or decrease the lifetime of the blades:

- Operation time and dimension of the work area.
- Length and thickness of the grass.
- Soil, sand and use of fertilizers.
- Objects such as cones, tools, stones and roots in the work area.

Note: The cutting result can be unsatisfactory if the blades are blunt. Refer to *Replacement of the blades on page 44* on how to replace the blades.

7.2 Maintenance schedule

The maintenance schedule shows how to do servicing and maintenance on the product. Follow the maintenance schedule for a better operation and to increase the lifetime of the product.

X = The instructions are given in this operator's manual.

O = The instructions are not given in this operator's manual. Speak to your approved servicing dealer.

| To prepare | Weekly | Every year | Every third year |
|---|--------|------------|------------------|
| Clean the product. Refer to <i>Clean the product on page 42</i> . | X | | |
| Examine the product for damage and wear. | X | | |
| Do an update of the firmware. | X | | |
| Do a check of the servicing messages for recommended upgrades. | | O | |
| Servicing | | | |
| Examine the blades and replace the blades and blade screws if it is necessary. Refer to <i>Replacement of the blades on page 44</i> . | X | | |
| Examine and polish the contact plates on the charging station. | | X | |
| Examine and polish the charging plates on the product. | | X | |
| Charge the battery fully before you put the product into storage. Refer to <i>To charge the battery on page 40</i> . | | X | |
| Examine the wheels for wear. | | O | |
| Examine and clean the collision columns. Do a check of the tightening torque on the front and rear collision columns. | | O | |
| Make sure that the product is docking and charging correctly. | | O | |
| Examine the cable and connector to the charging plates on the body of the product. | | O | |

| To prepare | Weekly | Every year | Every third year |
|--|--------|------------|------------------|
| Examine the skid plate and skid plate bearing. | | ○ | |
| Examine the rubber bellows in the cutting height adjustment system. | | ○ | |
| Examine the rubber bellows for the collision columns. | | ○ | |
| Replace the rubber bellows for the collision columns. | | | ○ |
| Examine and clean the airflow filter. | | ○ | |
| Replace the airflow filter. | | | ○ |
| Do a check of the tightening torque of chassis screws. | | ○ | |
| Open the chassis and replace all sealing strips. | | | ○ |
| Last step | | | |
| Use a software service tool to do a function test of the functions of the product. | | ○ | |

7.3 Clean the product



CAUTION: Do not use a high-pressure washer to clean the product. Do not use solvents for cleaning.

The product does not operate satisfactorily in slopes if the wheels are blocked with grass. Clean the product with a brush or running water from a water hose.

Husqvarna recommends to use a special cleaning and maintenance kit. Speak to your Husqvarna servicing dealer for more information.

7.3.1 To clean the blade discs and blade disc guard

Examine the blade disc and blades and clean the blade disc guard weekly.

1. Put the product onto its side.

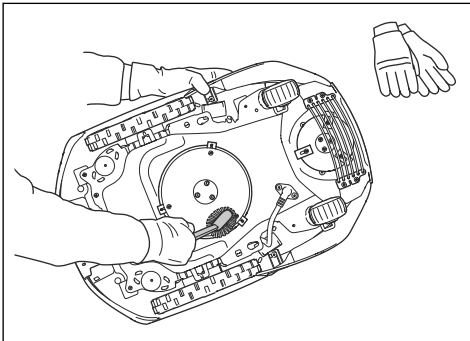

2. Clean the blade discs and the blade disc guard with a brush and running water.

7.3.2 To clean the chassis and body of the product

To clean the product fully, the top cover and the body of the product can be removed. If the product is dirty, use a weak soap solution if necessary. Use a brush or a water hose to clean the product. Do not use a high-pressure washer to clean the product.

1. Set the product to OFF.
2. Carefully pull the top cover at the rear.

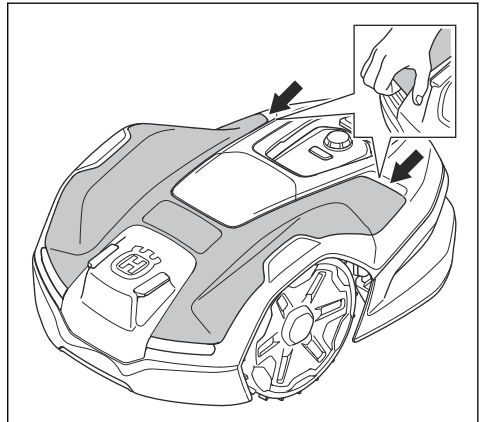

3. Hold the chassis with one hand and remove the body with a fast and short pull upwards and towards the front of the product.

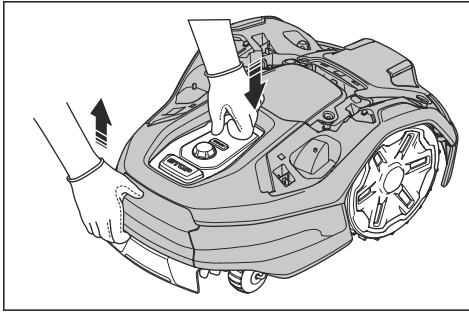

WARNING: If your hands come between the body of the product and the chassis, there is a risk of injury.

4. Hold the front wheel with one hand and remove the front part of the body with a fast and short pull upwards. Do the same procedure on the other side.

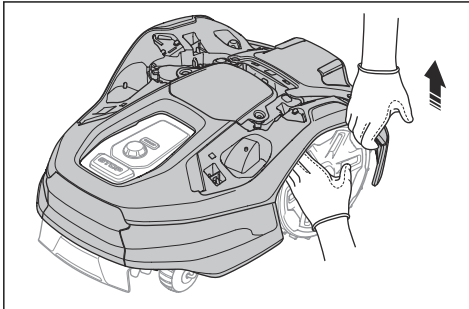

5. Put the body of the product adjacent to the chassis of the product or tilt it against a wall.

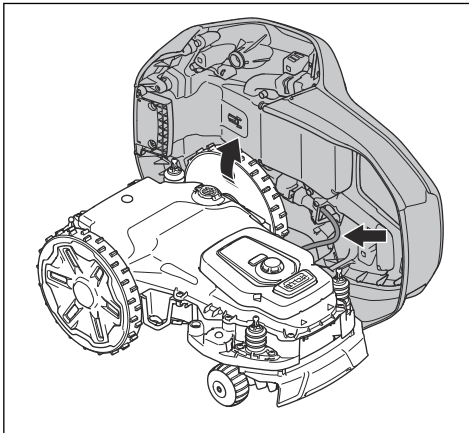

7.3.3 To clean the wheels

The product does not operate satisfactorily in slopes if the wheels are blocked with grass.

- Use a soft brush to clean the wheels.
- If it is necessary, remove the wheel cover with a flat screwdriver.

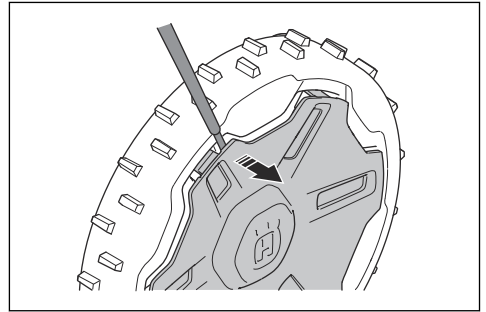

7.3.4 To clean the charging station



WARNING: Disconnect the power supply from the power outlet before maintenance, or when you clean the charging station or power supply.

- Remove grass, twigs and other objects from the charging station.
- Use a brush or a water hose to clean the charging station.

7.4 Battery



CAUTION: Charge the battery fully before you put the product into storage. If the battery is not fully charged it can cause damage to the battery.

If the operating time of the product is shorter than usual between charges, this means that the battery is at the end of its life cycle. Replace the battery to extend the operating time.

Note: The battery life is related to the length of the season and how many hours a day the product operates. A long season or many hours of operation a day means that the battery must be replaced more regularly.

7.5 Replacement of the blades



WARNING: Husqvarna can only guarantee safety if you use Husqvarna original blades with the embossed crowned H-mark logotype.

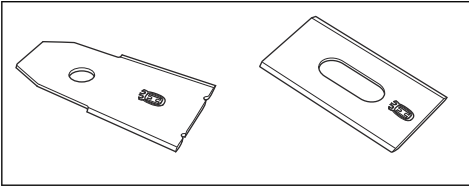

WARNING: You must replace the screws when you replace the blades. The used screws can wear quickly and make the blade come loose, this can cause serious injury.

Replace worn or damaged blades for a safe operation. Replace the blades regularly for a satisfactory cut result and a low energy use. All 3 blades and screws must be replaced at the same time to get a balanced cutting system.

7.5.1 To replace the blades

1. Set the product to OFF.
2. Put the product with the blade disc up on a clean and soft surface.
3. Rotate the skid plate until the holes align with the screws for the blade.
4. Remove the 3 blades and 3 screws.

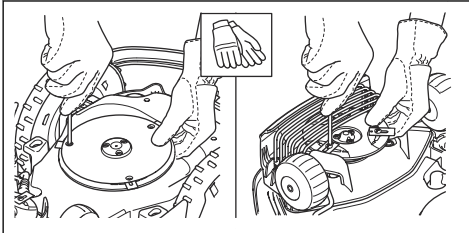

5. Attach new blades and screws.
6. Make sure that the blades can move freely.

8 Troubleshooting

8.1 Messages

The messages in the table below are shown in Automower® Connect and Automower® Access. Speak to your Husqvarna representative if the same message shows frequently.

| Message | Cause | Action |
|---|---|---|
| <i>Wheel motor blocked, right</i> | The drive wheel is blocked by grass or other objects. | Examine the drive wheel and remove the grass or other object. |
| <i>Wheel motor overloaded, left/right</i> | | |
| <i>Wheel drive problem, right/left</i> | The drive wheel is blocked by grass or other objects. | Examine the right drive wheel and remove the grass or other objects. If the problem stays, speak to your authorized service center. |
| <i>Cutting system blocked</i> | The cutting system is blocked by grass or other objects. | Examine the cutting system and remove the grass or other objects. |
| <i>Cutting height blocked</i> | Grass or other objects are wound around the cutting height adjustment, or between the blade disc and chassis. | Examine the blade disc and the bellows around the cutting height adjustment, and remove any grass or other objects that may have got stuck. |
| <i>Edge cutting system blocked</i> | The edge cutting system is blocked by grass or other objects. | Examine the edge cutting system and remove the grass or other objects. |
| <i>Imbalanced edge cutting system</i> | The product has discovered vibrations in the edge blade disc. | Examine that the blades and screws are not damaged or worn. Make sure that all blades are correctly installed and that there is only one blade attached in each position on the blade disc. |

| Message | Cause | Action |
|-----------------------|---|---|
| <i>No loop signal</i> | The power supply or the low-voltage cable are not connected. | Examine the LED status on the charging station. If the LED is not lit, it indicates that there is no power. Examine the power outlet connection and whether an earth-fault breaker has tripped. Make sure that the low-voltage cable is connected to the charging station. |
| | The power supply or low-voltage cable are damaged. | Replace the power supply or low-voltage cable. |
| | <i>ECO mode</i> is activated and the product has attempted to start outside the charging station. | Put the product in the charging station. Start the product. |
| | The product does not find the loop signal from the charging station. | Put the product in the charging station and generate a new loop signal. Refer to <i>To install the boundary wire on page 30</i> . |
| | Disturbances from metal objects (fences, reinforcement steel) or buried cables. | For a wire installation, move the boundary wire and/or make more islands in the work area to increase the signal strength. For an EPOS™ installation, change the position of the charging station. |
| | For a wire installation, the boundary wire is not connected to the charging station. | Make sure that the boundary wire connectors are fitted properly to the charging station. Replace connectors if damaged. Refer to <i>To install the boundary wire on page 30</i> . |
| | For a wire installation, the boundary wire is crossed on its way to and from an island. | Make sure that the boundary wire is installed correctly. Refer to <i>To enable the loop signal on page 34</i> . |
| | For a wire installation, the boundary wire is broken. | Check the signal given by the LED on the charging station. If the LED indicates break in the boundary wire, find out where the break is. Replace the damaged section of the loop with a new loop wire and splice using an original coupler. Refer to <i>To install the boundary wire on page 30</i> . |
| | For a wire installation, the product is too far from the boundary wire. | Redo the installation of the boundary wire so that all parts of the work area is maximum m / ft. from the boundary wire. |

| Message | Cause | Action |
|--------------------------|---|--|
| <i>Outside work area</i> | The boundary wire connections to the charging station are crossed. | Make sure that the boundary wire is connected correctly. Refer to <i>To install the boundary wire on page 30</i> . |
| | The boundary wire is too close to the edge of the work area. | Make sure that the boundary wire has been laid according to the instructions. Refer to <i>To install the boundary wire on page 30</i> . |
| | The boundary wire, virtual boundary or virtual transport paths are installed in an area with too steep slope. | |
| | The boundary wire is laid in the wrong direction around an island. | |
| | Disturbances from metal objects (fences, reinforcement steel) or buried cables close by. | Move the boundary wire and/or make more islands in the work area to increase the signal strength. |
| | The product finds it hard to distinguish the signal from another product installation close by. | Put the product in the charging station and generate a new loop signal. Refer to <i>New loop signal on page 37</i> . |
| <i>Upside down</i> | The product is leaning too much or has turned over. | Turn the product the right way up. |
| <i>Mower tilted</i> | The product tilts too much. | Move the product to a level area. |
| <i>Lifted</i> | The lift sensor has been enabled because the product has been lifted. | Make sure that the body of the product body can move freely around its chassis. Remove or make an island around objects that can cause the body to be lifted. If the problem stays, speak to your authorized service center. |
| <i>Trapped</i> | The product is blocked in a small area behind a number of obstacles. | Examine if there are obstacles which make it hard for the product to move away from this location. |
| <i>Slipped</i> | The product slips because there is an obstacle. | Remove the obstacle. |
| | The product slips because of wet grass. | Wait until the lawn is dry before you start the product again. |
| | The product has hit an obstacle and stopped or the wheels cannot move on the wet grass. | Free the product and rectify the reason for the lack of drive. If it is due to wet grass, wait until the lawn has dried before using the product. |
| | The product slips because the slope is too steep. | Isolate the steep slope with boundary wire. Refer to <i>To put the boundary wire in a slope on page 26</i> . |
| | The product slips because the slope is too steep when it follows the guide wire. | Make sure that the guide wire is installed diagonally in the slope. Refer to <i>To put the boundary wire in a slope on page 26</i> . |

| Message | Cause | Action |
|---------------------------------------|---|---|
| <i>Collision</i> | The body of the product cannot move freely around its chassis. | Make sure that the body of the product can move freely around its chassis. Examine that the body of the product is correctly installed and there is no dirt blocking it. If the problem stays, speak to your authorized service center. |
| <i>Alarm! Mower stopped</i> | The alarm was started because the product was stopped. | Enter the PIN code to disable the alarm. The settings for the alarm can be changed in the <i>Security</i> menu. Refer to <i>Security on page 36</i> . |
| | The alarm was started because the product was lifted. | |
| | The alarm was started because the product was tilted. | |
| <i>Alarm! Mower was moved</i> | The alarm was started because the product was moved. | |
| <i>Alarm! Outside Geo-Fence</i> | The alarm was started because the product was outside the GeoFence. | |
| <i>Temporary problem</i> | Temporary electronic or firmware problem in the product. | Update the firmware via FOTA. Restart the product. If the problem stays, speak to your authorized service center. |
| <i>Electronic problem</i> | Temporary electronic or firmware problem in the product. | Restart the product. |
| <i>Loop sensor problem</i> | | If the problem stays, speak to your approved servicing dealer. |
| <i>Tilt sensor problem</i> | | |
| <i>Invalid sub-device combination</i> | | |
| <i>STOP button problem</i> | | |
| <i>Connectivity problem</i> | | |
| <i>Safety function faulty</i> | | |
| <i>Invalid system configuration</i> | | |
| <i>Lift sensor problem</i> | | |
| <i>Collision sensor problem</i> | | |
| <i>Radar problem</i> | | |
| <i>Temporary battery problem</i> | | |
| <i>Battery problem</i> | | |
| | Incorrect type of battery. | Use only original batteries recommended by the manufacturer. |

| Message | Cause | Action |
|---|---|---|
| <i>Empty battery</i> | For an installation with boundary wire: The product cannot find the charging station. | Change the position of the guide wire. Refer to <i>To install the guide wire on page 30</i> . Check the installation settings about how to find the charging station. Refer to <i>To find the charging station on page 35</i> . |
| | For an EPOS™ installation: The product cannot find the charging station. | The product has no accurate position and cannot find the charging station. There is an obstacle that causes the product to not find the charging station. |
| | The battery is spent. | Replace the battery. Refer to <i>Battery on page 43</i> . |
| | The charging station's antenna is defective. | Check if the indicator lamp in the charging station flashes red. Refer to <i>To install the guide wire on page 30</i> . |
| <i>Battery needs re- placement</i> | The battery state of health is low. | Replace the battery. Speak to your authorized service center. |
| <i>Battery near end of life</i> | The battery state of health is critically low. | Replace the battery. Speak to your authorized service center. |
| <i>Temperature restric- tion</i> | The product does not operate if the battery temperature is too high or too low. | The product starts to operate again when the temperature is between the set limits and the schedule settings let the product to operate. Make sure that the charging station is put in an area with protection from the sun. |
| <i>Charging current too high</i> | The battery charges with a too high current. The power supply unit is incorrect or damaged. | Make sure that the power supply unit and charging station are not damaged. Make sure the that you use the correct power supply unit and charging station. Restart the product. If the problem stays, speak to your authorized service center. |
| <i>Charging system problem</i> | There is corrosion or dirt on the charging plates and contact plates. | Restart the product. Clean the charging plates on the product and the contact plates on the charging station. |
| | Temporary electronic or firmware problem in the product. | Restart the product. If the problem stays, speak to your approved servicing dealer. |
| <i>No power in charging station</i> | The power supply unit is incorrect or damaged. | Examine the power supply unit. Replace if necessary. |
| | Power failure. | Find and correct the cause of the power failure. |
| | The product cannot charge because there is no contact between the contact plates and the charging plates. | Make sure that the charging plates and the contact plates are in contact. Clean the contact plates and charging plates. |

| Message | Cause | Action |
|---|--|---|
| <i>Charging station blocked</i> | The product cannot go into the charging station because it is blocked or the baseplate of the charging station is tilted or bent. | Examine why the product cannot go into the charging station. Remove any objects and make sure that the baseplate of the charging station is level. |
| | The product cannot go into the charging station because it is blocked or the baseplate of the charging station is tilted or bent. | Examine why the product cannot go into the charging station. Remove any objects and make sure that the baseplate of the charging station is level. |
| <i>Stuck in charging station</i> | The product cannot leave the charging station because it is blocked or it slips on the baseplate of the charging station. | Examine why the product cannot leave the charging station. Remove any objects and clean the baseplate of the charging station. |
| <i>FlexiFence problem</i> | The battery of the FlexiFence accessory is low. The FlexiFence accessory does not operate when the battery is empty. The product can cut in the stay-out zone if you start the product before you charge the FlexiFence accessory. | Park the product and charge the FlexiFence accessory before you start the product. |
| | The temperature in the FlexiFence accessory is a higher than the maximum limit and is set to off. | Put the product in an area with protection from the sun. Let the temperature of the FlexiFence accessory decrease before you start the product. |
| <i>Slope too steep</i> | The product stopped because the slope is too steep. | Change the installation of the boundary wire to exclude this steep part of the work area. |
| <i>EPOS plug-in not found</i> | The EPOS Plug-in has been installed earlier, but cannot be found. | Make sure that the EPOS Plug-in is installed correctly and that the cable is connected. Restart the product. If the problem stays, speak to your authorized service center. |
| <i>Charging station communication problem</i> | The mower cannot communicate with the charging station. | Create a new loop signal or reinstall your charging station under map view in the app. If the problem stays speak to your authorized service center. |
| | Power failure | Find and correct the cause of the power failure. |
| <i>Invalid firmware configuration</i> | The firmware in the product is not updated. | Update the firmware to the latest version. |
| <i>Map problem</i> | The map object file is incorrect. | Do a check of the map in the app. Adjust the map and save it. |
| | | Delete the map and do a new installation. |
| <i>Accessory power problem</i> | There is a power problem with the accessory port. | Switch off the product and disconnect and reconnect the accessory to the accessory port. Restart the product. If the problem stays, speak to your service center. |

| Message | Cause | Action |
|--|---|---|
| <i>Destination not reachable</i> | The product cannot reach the destination because there is a stay-out blocking the way to the work area. | Edit or remove the stay-out zone or make a new installation of the work area. |
| | For EPOS™ installation, there is no transport path to the work area. | Edit or remove the stay-out zone or make a new installation of the work area. |
| | For EPOS™ installation, the way back to the charging station is blocked by an obstacle. | Remove the obstacle. |
| | For EPOS™ installation, the way to the maintenance point is blocked by an obstacle. | |
| <i>Destination blocked</i> | The way of the destination is blocked by an obstacle. | Remove the obstacle that blocks the way to the destination. |
| | The way of the destination is blocked by a stay-out zone. | Edit or remove the stay-out zone or make a new installation of the work area. |
| | For EPOS™ installation, there is no transport path to the work area. | Make a transport path to the work area. |
| <i>Boundary wire problem</i> | The boundary wire for the <i>Support by wire</i> function is damaged or not installed correctly. | Examine that the boundary wire is connected correctly to the charging station. Examine all the splices on the boundary wire. Examine if the boundary wire is damaged and repair it if it is necessary. |
| <i>Unexpected cutting height adj</i> | The cutting height adjustment cannot move. | Examine the cutting height adjustment and remove grass or other objects. If the problem stays, speak to your approved servicing dealer. |
| <i>Limited cutting height range</i> | | |
| <i>Cutting height problem</i> | | |
| <i>Cutting system imbalance</i> | The product has discovered vibrations in the blade disc. | Make sure that the blades and screws are not damaged and worn. Make sure that all blades are correctly installed and that there is only one blade attached in each position on the blade disc. Clean the blades and the cutting disc. |
| <i>Guide 1 not found</i> <i>Guide 2 not found</i> <i>Guide 3 not found</i> | The guide wire you have installed before is not found. | Examine if the guide wire is not correctly connected to the charging station or the boundary wire. Examine if there is a break in the guide wire. Refer to <i>Finding breaks in the loop wire on page 55</i> . |
| <i>GPS navigation problem</i> | Problem with the GPS assisted navigation equipment. | Restart the product. If the problem stays, speak to your authorized service center. |
| <i>Weak GPS signal</i> | The GPS signal is blocked in large parts of the work area. | If possible, remove objects that can cause a blockage of the GPS signal. |
| | | Disable the GPS navigation function and use the lawn coverage function. Refer to <i>Lawn coverage on page 35</i> . |
| <i>Work area tampered</i> | The charging station or the reference station was moved. | Do a new installation of the map. |

| Message | Cause | Action |
|--|---|--|
| <i>Too many waypoints</i> | There are too many waypoints in the current work area. | Do a new installation of the work area, stay-out zone and transport paths. Divide the current work area into more work areas. |
| <i>No correction data available</i> | Technical problems with EPOS™ through the Husqvarna® Cloud. | Restart the product. If the problem remains, the message requires action by authorized service technician. |
| | The product does not have cellular connection and cannot receive correction data. | Make sure that you have cellular coverage in all parts of the area where the product operates. |
| <i>Searching for position</i> | Weak satellite signal to the reference station. | The satellite signal is temporarily weak. The product will start to operate when the satellite signals are good. |
| | | Examine the installation of the reference station. |
| | Weak satellite signal to the product. | The satellite signal is temporarily weak. The product will start to operate when the satellite signal is good. |
| | | Examine if there is an object between the product and the sky that causes interference with the satellite signal. Remove the object or do a new installation to not include these parts in the work area. Refer to <i>Installation of the map objects on page 19</i> . |
| <i>Reference station communication problem</i> | The product is not connected to the reference station. | Do a pairing operation between the product and the reference station. |
| | The reference station is not installed correctly. | Examine the installation of the reference station. |
| | The product does not receive the radio signal from the reference station in all areas where the product operates. | Test if the product has radio signal from the reference station in all of the work area. If not, make a new installation of the reference station or a new installation of the map. Refer to <i>Installation of the map objects on page 19</i> . |
| | Power failure. | Examine and correct the cause for the power failure of the reference station. |
| | There is an error in the reference station and the LED indicator flashes red. | Disconnect the power to the reference station and connect it again to restart the reference station. If the problem stays, speak to your approved servicing dealer. |
| | There is interference with another reference station or other radio systems in the area. | Restart the product. If the problem stays, speak to your approved servicing dealer. |

8.2 LED indicator of the charging station

The LED indicator of the charging station is green when the installation is correct. If the LED indicator of the

charging station is not green, follow the troubleshooting table below.

Speak to your local Husqvarna representative or go to www.husqvarna.com for more information.

| LED indicator | Cause | Action |
|----------------|---|--|
| Constant green | The signals of the charging station are good. | No procedure is necessary. |
| Flashes green | The signals of the charging station are good and <i>ECO mode</i> is enabled. | No procedure is necessary. |
| Flashes blue | The boundary wire is not connected to the charging station. | Connect the boundary wire to the charging station. |
| | The boundary wire is damaged. | Replace the damaged section of the boundary wire with new boundary wire. |
| Flashes red | Interference in the antenna of the charging station. | Speak to your local Husqvarna representative. |
| Constant red | Error in the circuit board or incorrect power supply in the charging station. | The error must be corrected by an authorized service technician. Speak to your local Husqvarna representative. |

8.3 Symptoms

If the product does not operate as usual, follow the symptoms table below. Speak to your Husqvarna customer service if you cannot find the cause for the fault.

| Symptoms | Cause | Action |
|---|--|---|
| Edges of the lawn are not satisfactorily cut. | The blade disc guard for the EdgeCut blade disc is clogged. | Clean the blade disc guard for the EdgeCut blade disc. |
| | The edges of the lawn were not cut before the installation of the product. | Use a grass trimmer to cut the edges of the lawn. |
| | The grass is thick and grows quickly. | Increase the scheduled cutting time for the product. |
| The product has difficulty docking. | The guide wire is not put straight in a line and correct distance from the charging station. | Do a check of the installation of the charging station. Refer to <i>To install the charging station on page 29</i> |
| | The guide wire is not put in the slot in the charging station plate. | Make sure that the guide wire is put straight in a line and put in the slot in the charging station plate. Refer to <i>To install the guide wire on page 30</i> . |
| | The charging station is not on a level surface. | Put the charging station on a level surface. Refer to <i>To examine where to put the charging station on page 24</i> . |
| The product operates at the incorrect time. | The time or the date in the product is not correct. | Set the time or date. Refer to <i>Time & date on page 36</i> . |
| | The start and stop times for operating are incorrect. | Change the <i>Schedule</i> settings. Refer to <i>Schedule on page 33</i> . |

| Symptoms | Cause | Action |
|--|---|---|
| There is vibration in the product. | The cutting system is not in balance because of damaged blades. | Examine the blades and screws and replace them if necessary. Refer to <i>Replacement of the blades on page 44</i> . |
| | The cutting system is not in balance because of too many blades in the same position. | Do a check that only one blade is attached at each screw. |
| | Different thickness of blades are installed on the product. | Do a check if the blades are of different thickness and replace if necessary. |
| The product operates, but the blade disc does not rotate. | The product searches for the charging station, or is moving to the starting point. | Usual operation for the product. The blade disc does not rotate when the product is searching for the charging station. |
| The product operates for shorter periods than usual between charges. | Grass or other object causes a blockage to the blade disc. | Remove and clean the blade disc. Refer to <i>Clean the product on page 42</i> . |
| | The battery is at the end of its life cycle. | Replace the battery. Refer to <i>Replacement of the blades on page 44</i> . |
| | Blunt blades. More energy is necessary when cutting the grass. | Replace the blades. Refer to <i>Replacement of the blades on page 44</i> . |
| Mowing and charging times are shorter than usual. | The battery is at the end of its life cycle. | Replace the battery. Refer to <i>Battery on page 43</i> . |
| The product is parked for hours in the charging station. | The product has operated the maximum cutting time for the day. | No action. Refer to <i>Schedule on page 33</i> . |
| | The hatch is closed but the START button is not pushed. | Push the STOP button to open the hatch. Enter the PIN code and confirm with the OK button. Push the START button and then close the hatch. |
| | Parking mode is enabled. | Change the operating mode. Refer to <i>Operating modes - Start on page 39</i> . |
| | The product does not operate if the battery temperature is too high or too low. | Make sure that the charging station is put in an area with protection from the sun. |
| The cutting result is not satisfactory. | The product operates for a small number of hours per day. | Increase the cutting time. Refer to <i>Schedule on page 33</i> . |
| | For the shape of the work area it is necessary to adjust the settings for <i>Lawn Coverage</i> to cover all parts of the work area. | Change the settings of the areas where the product starts to cut and how often. Refer to <i>Lawn coverage on page 35</i> . |
| | The work area is too large. | Decrease the size of the work area or extend the schedule. Refer to <i>Schedule on page 33</i> . |
| | Blunt blades. | Replace all the blades. Refer to <i>Replacement of the blades on page 44</i> . |
| | Long grass in relation to the set cutting height. | Increase the cutting height and then lower it when the grass is shorter. |
| | Collection of grass on the blade disc or around the motor shaft. | Remove the collection of grass and clean the product. Refer to <i>Clean the product on page 42</i> . |

| Symptoms | Cause | Action |
|---|--|--|
| The battery is empty and you put the product in the charging station, but it does not charge and cannot be set to ON. | If the battery has been deeply discharged, it will take a long time to charge the battery and before the product can be set to ON. | Keep the product in the charging station for 24 hours and test if the product can be set to ON. If the problem stays, speak to your authorized service technician. |

8.4 Finding breaks in the loop wire

Breaks in the loop wire are usually the result of unintentional physical damage to the wire such as when gardening with a shovel. In countries with ground frost, also sharp stones that move in the ground can damage the wire. Breaks can also occur due to the wire being stretched excessively during installation.

Mowing the grass too low right after the installation can damage wire insulation. Damage to the insulation may not cause disruptions until several weeks or months later.



CAUTION: Always select the maximum cutting height the first weeks after installation and then lower the height one step at a time every second week until the desired cutting height has been reached.

A damaged splicing of the loop wire can also lead to disruptions several weeks after the splice was done. A faulty splice can, for example, be the result of the coupler not being pressed together hard enough with a pair of pliers, or that a coupler of lower quality than the original coupler has been used.

Note: Please first check all known splices before further troubleshooting is done.

A wire break can be located by gradually halving the distance of the loop where the break may have occurred until there is only a very short section of the wire left.

The following method does not work if *ECO mode* is activated. Make sure first that *ECO mode* is turned off. Refer to *ECO mode on page 34*.

- Check that the indicator lamp in the charging station flashes blue, which indicates a break in the boundary loop. Refer to *LED indicator of the charging station on page 52*.
- Check that the boundary wire connections to the charging station are properly connected and not damaged. Check that the indicator lamp in the charging station is still flashing blue.
- Switch the connections between the guide wire and the boundary wire in the charging station.
 - If the suspected boundary wire is short then it is easiest to exchange all of the boundary wire between AL and the point where the guide wire is connected to the boundary wire (thick black line).
 - If the suspected boundary wire is long (thick black line) then do as follows: Put AL and G1 back to their original positions. Then disconnect AR. Connect a new loop wire to AR. Connect the other end of this new loop wire at the middle of the suspected wire section.

Start by switching connection AL and G1. Some models have additional guide wires. The same procedure can be followed for them.

If the indicator lamp is lit with a solid green light, then the break is somewhere on the boundary wire between AL and the point where the guide wire is connected to the boundary wire (thick black line in the illustration).

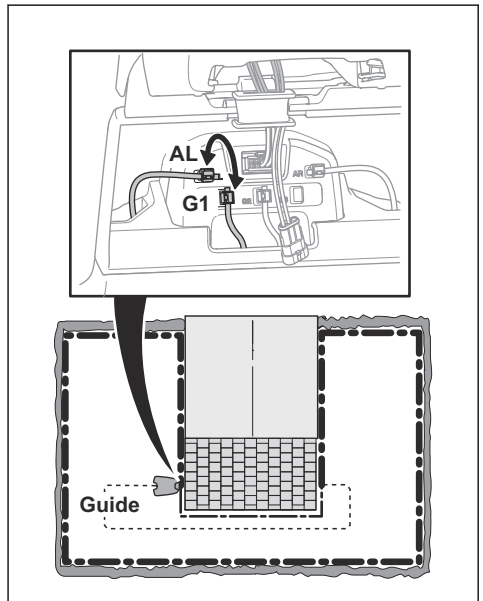

To rectify the fault you will need boundary wire, connector(s) and coupler(s):

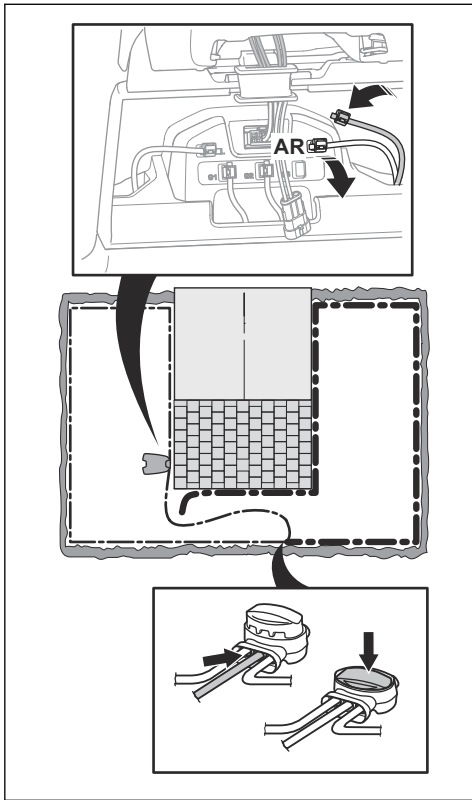

If the indicator lamp now is green, then the break is somewhere in the wire between the disconnected end to the point where the new wire is connected (thick black line below). In that case, move the connection for the new wire closer to the disconnected end (roughly at the middle of the suspected wire section) and check again if the indicator lamp is green.

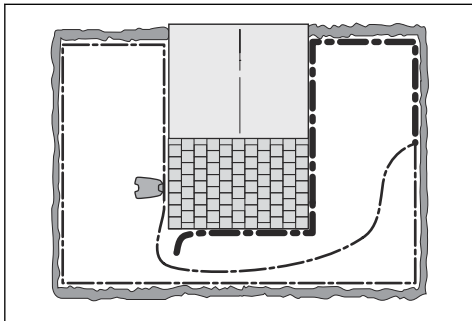

Continue until only a very short section of the wire remains which is the difference between a solid green light and a flashing blue light. Then follow instruction in step 5 below.

4. If indicator lamp still flashes blue in step 3 above: Put AL and G1 back in their original positions. Then switch AR and G1. If indicator lamp now is lit with a solid green light then disconnect AL and connect a new boundary wire to AL. Connect the other end of this new wire at the middle of the suspected wire section. Follow the same approach as in 3a) and 3b) above.
5. When the break is found, the damaged section must be replaced with a new wire. Always use original couplers.

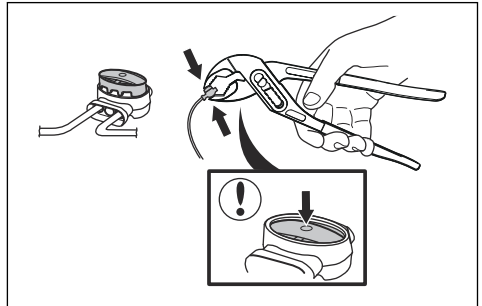

9 Transportation, storage and disposal

9.1 Transportation

The supplied Li-ion batteries obey the Dangerous Goods Legislation requirements.

- Obey all applicable national regulations.
- Obey the special requirement on package and labels for commercial transportations, including by third parties and forwarding agents.
- For how to remove the battery, refer to the complete Operator's manual on www.husqvarna.com.

9.2 To put the product into storage



CAUTION: Charge the battery fully before you put the product into storage. If the battery is not fully charged it can cause damage to the battery.

- Charge the product fully. Refer to *To charge the battery on page 40*.
- Set the product to OFF. Refer to *To set the product to OFF on page 39*.
- Clean the product. Refer to *Clean the product on page 42*.
- Put the product in a dry, frost-free area.
- We recommend to put the product in the package of the product or put the product with all wheels on level ground. You can also hang the product on a Husqvarna wall hanger. Speak to your Husqvarna representative for more information about available wall hangers.

9.3 To put the charging station into storage

You can remove the top of the charging station and put it into storage. It is not necessary to put the baseplate of the charging station into storage.

1. Lift and tilt the top of the charging station and open the hatch.
2. Disconnect the power supply unit from the charging station and from the power outlet.
3. Disconnect the cable.

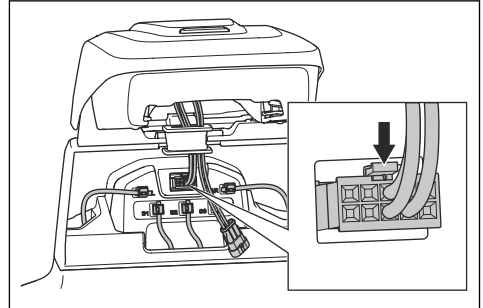

4. Remove the grommet with the cables.
5. Pull the top of the charging station up and remove it.
6. Close the sealing lid.

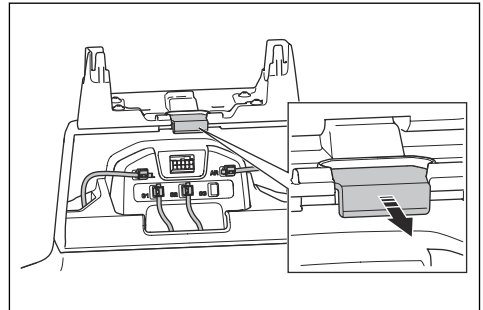

7. Close the hatch.
8. Put the power supply unit and the top of the charging station in a dry, frost-free area.

9.4 To install the charging station after storage

1. Open the hatch.
2. Push in the sealing lid.
3. Attach the top of the charging station.

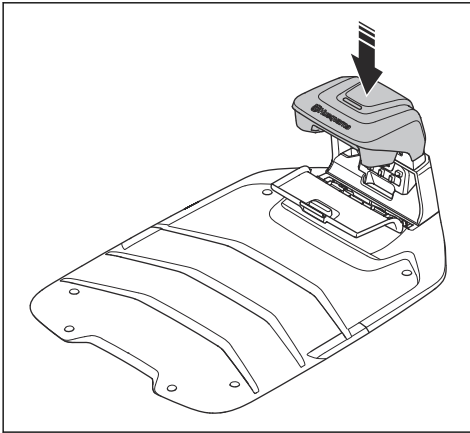

4. Lift and tilt the top of the charging station.
5. Put the grommet with the cables into position.
6. Connect the cable to the charging station.

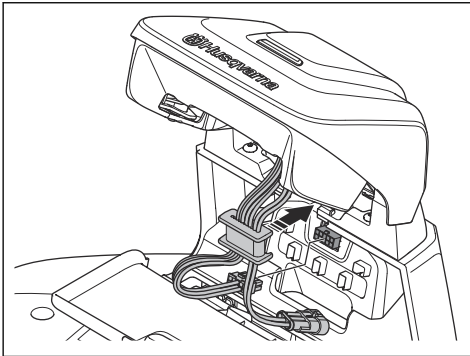

7. Connect the power supply unit to the power outlet and to the charging station.
8. Close the hatch.

9.5 Disposal

- Obey the local recycling requirements and applicable regulations.
- For questions about how to remove the battery, refer to *To remove the battery on page 58*.

9.5.1 To remove the battery

1. Set the product to OFF.
2. Remove the body of the product, refer to *To clean the chassis and body of the product on page 42*.
3. Remove the 12 screws.

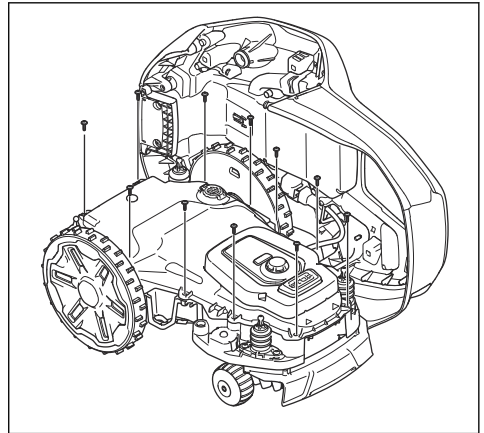

4. Remove the warranty seal and lift up the lower chassis.
5. Disconnect the 2 cables (A) and (B) from the battery.

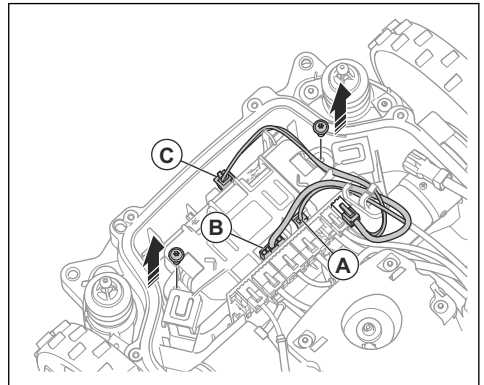

6. Disconnect the cable (C) from the front loop circuit board.
7. Remove the 2 screws for the battery holder.
8. Remove the battery.

10 Technical data

10.1 Technical data

| Dimensions | Automower® 305E NERA | Automower® 310E NERA | Automower® 405XE NERA | Automower® 410XE NERA |
|-------------------|---------------------------------|---------------------------------|----------------------------------|----------------------------------|
| Length, cm/in. | 68/26.8 | 68/26.8 | 68/26.8 | 68/26.8 |
| Width, cm/in. | 44/17.2 | 44/17.2 | 44/17.2 | 44/17.2 |
| Height, cm/in. | 28/11.0 | 28/11.0 | 28/11.0 | 28/11.0 |
| Weight, kg/lb | 12.2 / 27 | 12.2 / 27 | 12.1 / 27 | 12.1 / 27 |

| Electrical system | Automower® 305E NERA | Automower® 310E NERA | Automower® 405XE NERA | Automower® 410XE NERA |
|---|--|--|--|--|
| Battery, Lithium-Ion 18.0 V/2.0 Ah Art. No. | 593 74 20-03, 593 74 20-04, 593 74 20-06 | 593 74 20-03, 593 74 20-04, 593 74 20-06 | | |
| Battery, Lithium-Ion 18. V/4.9 Ah Art. No. | | | 590 81 01-02 | 590 81 01-02 |
| Battery, Lithium-Ion 18.0 V/5.0 Ah Art. No. | | | 536 81 24-01, 590 81 01-01, 590 81 01-03 | 536 81 24-01, 590 81 01-01, 590 81 01-03 |
| Battery, Lithium-Ion 18.5 V/5.0 Ah Art. No. | | | 536 81 24-02 | 536 81 24-02 |
| Battery, Lithium-Ion 18.0 V/5.2 Ah Art. No. | | | 590 81 01-04 | 590 81 01-04 |
| Power supply (28V DC), V AC | 100-240 | 100-240 | 100-240 | 100-240 |
| Low-voltage cable length, m/ft | 10/32.8 | 10/32.8 | 10/32.8 | 10/32.8 |
| Mean energy consumption at maximum use | 7 kWh/month | 11 kWh/month | 11 kWh/month | 13 kWh/month |
| Charging current, A DC | 2.2 | 2.2 | 2.2 | 2.2 |
| Type of Power Supply Unit ¹³ | FW7438/28/D/XX /Y, ADP-60PR XX | FW7438/28/D/XX /Y, ADP-60PR XX | FW7438/28/D/XX /Y, ADP-60PR XX | FW7438/28/D/XX /Y, ADP-60PR XX |
| Average mowing time, min | 50 | 50 | 100 | 100 |
| Average charging time, min | 40 | 40 | 90 | 90 |

¹³ XX, YY can be any alphanumeric characters or blank for marketing purpose only, no technical differences.

| Boundary wire antenna | Automower® 305E NERA | Automower® 310E NERA | Automower® 405XE NERA | Automower® 410XE NERA |
|--|-------------------------|-------------------------|--------------------------|--------------------------|
| Operating Frequency Band, Hz | 100-80000 | 100-80000 | 100-80000 | 100-80000 |
| Maximum magnetic field ¹⁴ , dBuA/m | 82 | 82 | 82 | 82 |
| Maximum Radio-frequency power ¹⁵ , mW@60m | <25 | <25 | <25 | <25 |

| Sound data ¹⁶ | Automower® 305E NERA | Automower® 310E NERA | Automower® 405XE NERA | Automower® 410XE NERA |
|---|-------------------------|-------------------------|--------------------------|--------------------------|
| Sound level, perceived, dB (A) | 60 | 60 | 60 | 60 |
| Measured sound power noise level, dB (A) | 60 | 60 | 59 | 59 |
| Noise emissions uncertainties, KWA dB (A) | 1 | 1 | 2 | 2 |
| Sound pressure noise level at the operator's ear ¹⁷ , dB (A) | 52 | 52 | 51 | 51 |

| Mowing | Automower® 305E NERA | Automower® 310E NERA | Automower® 405XE NERA | Automower® 410XE NERA |
|---|-------------------------|-------------------------|--------------------------|--------------------------|
| Power consumption during cutting, W+/- 20% | 20 | 20 | 25 | 25 |
| Number of guides | 2 | 2 | 3 | 3 |
| Narrowest possible passage, cm/in. | 60/24 | 60/24 | 60/24 | 60/24 |
| Maximum slope for work area ¹⁸ , % | 30 | 30 | 30 | 30 |
| Maximum slope for boundary wire, % | 20 | 20 | 20 | 20 |
| Maximum length boundary wire, m/ft | 800/2600 | 800/2600 | 800/2600 | 800/2600 |
| Maximum length guide loop ¹⁹ , m/ft | 400/1300 | 400/1300 | 400/1300 | 400/1300 |
| Maximum distance to boundary wire m/ft | 35/115 | 35/115 | 35/115 | 35/115 |
| Maximum operating time, mowing and charging, h/day | 15 | 24 | 15 | 24 |
| Area capacity - irregular, m ² / acre, +/- 20% | 600/0.15 | 1000/0.25 | 600/0.15 | 1000/0.25 |
| Area capacity - systematic with EPOS™, m ² / acre, +/- 20% | 900/0.23 | 1500/0.37 | 900/0.23 | 1500/0.37 |

¹⁴ Measured according to EN 303 447.

¹⁵ Maximum active output power to antennas in the frequency band in which the radio equipment operates.

¹⁶ Determined according to Directive 2006/42/EC and standard EN 50636-2-107. Except Sound level, perceived that is measured according to ISO 11094:1991.

¹⁷ Sound pressure noise uncertainties K_{pA}, 2-4 dB (A)

¹⁸ Terrain wheels are available as accessory to improve the slope performance.

¹⁹ The guide loop is the loop that is formed by the guide wire and the part of the boundary wire from the junction with the guide wire to the right connection in the charging station.

| Main blade disc | Automower® 305E NERA | Automower® 310E NERA | Automower® 405XE NERA | Automower® 410XE NERA |
|--------------------------|---------------------------------|---------------------------------|----------------------------------|----------------------------------|
| Cutting system | 3 pivoted cutting blades | 3 pivoted cutting blades | 3 pivoted cutting blades | 3 pivoted cutting blades |
| Cutting motor speed, rpm | 2300 | 2300 | 2300 | 2300 |
| Cutting height, cm/in. | 2-5.5/0.8-2.2 | 2-5.5/0.8-2.2 | 2-5.5/0.8-2.2 | 2-5.5/0.8-2.2 |
| Cutting width, cm/in. | 22/8.7 | 22/8.7 | 22/8.7 | 22/8.7 |

| EdgeCut blade disc | Automower® 305E NERA | Automower® 310E NERA | Automower® 405XE NERA | Automower® 410XE NERA |
|---------------------------|---------------------------------|---------------------------------|----------------------------------|----------------------------------|
| Cutting system | 3 pivoted cutting blades | 3 pivoted cutting blades | 3 pivoted cutting blades | 3 pivoted cutting blades |
| Cutting motor speed, rpm | 2670 | 2670 | 2670 | 2670 |
| Cutting height, cm/in. | 4.5/1.8 | 4.5/1.8 | 4.5/1.8 | 4.5/1.8 |
| Cutting width, cm/in. | 14/5.5 | 14/5.5 | 14/5.5 | 14/5.5 |

| IP-code | Automower® 305E NERA | Automower® 310E NERA | Automower® 405XE NERA | Automower® 410XE NERA |
|--------------------|---------------------------------|---------------------------------|----------------------------------|----------------------------------|
| Robotic lawn mower | IPX5 | IPX5 | IPX5 | IPX5 |
| Charging station | IPX5 | IPX5 | IPX5 | IPX5 |
| Power supply | IP44 | IP44 | IP44 | IP44 |

| Frequency Band Support | |
|-------------------------------|--|
| Automower® Connect 2G | GSM 850 MHz, E-GSM 900 MHz, DCS 1800 MHz, PCS 1900 MHz |
| Automower® Connect 4G | Band 12 (700 MHz), Band 13 (700 MHz), Band 17 (700 MHz), Band 28 (700 MHz), Band 85 (700 MHz), Band 20 (800 MHz), Band 5 (850 MHz), Band 18 (850MHz), Band 19 (850 MHz), Band 26 (850 MHz), Band 8 (900 MHz), Band 4 (1700 MHz), Band 66 (1700 MHz), Band 3 (1800 MHz), Band 2 (1900 MHz), Band 25 (1900 MHz), Band 39 (1900 MHz), Band 1 (2100 MHz) |

| Power Class | | |
|-------------------------|----------------------------|--------|
| Bluetooth® Output power | 9 dBm | |
| Automower® Connect 2G | Power Class 4 (GSM/E-GSM) | 33 dBm |
| | Power Class 1 (DCS/PCS) | 30 dBm |
| | Power Class E2 (GSM/E-GSM) | 27 dBm |
| | Power Class E2 (DCS/PCS) | 26 dBm |
| Automower® Connect 4G | Power Class 3 | 23 dBm |

| | |
|--------------------------------------|--|
| Wi-Fi | Automower® 310E NERA/Automower® 410XE NERA |
| Frequency band support ²⁰ | Channel 1-11 (2412-2462 MHz) |
| | Channel 12-13 (2467-2484 MHz) |
| | Channel 14 |
| Operating frequency band, MHz | 2402-2480 |
| Maximum transmitted power, dBm | 20 |

Husqvarna AB does not guarantee full compatibility between the product and other types of wireless systems such as remote controls, radio transmitters, hearing loops, underground electric animal fencing or similar.

10.1.1 Registered trademarks

The *Bluetooth*® word mark and logos are registered trademarks owned by *Bluetooth SIG, inc.* and any use of such marks by Husqvarna is under license.

The Wi-Fi CERTIFIED™ logo is a registered trademark of Wi-Fi Alliance®. This product is Wi-Fi Alliance® certified.



²⁰ Channel 12-14 is only used in countries where it is available.



Husqvarna[®]

AUTOMOWER[®] is a trademark owned by Husqvarna AB.
Copyright[®] 2025 HUSQVARNA. All rights reserved.

www.husqvarna.com

Original instructions



FR

1144028-26



2025-02-24