

FOR WORD

You have just purchased a Honda pedestrian-controlled lawnmower and we thank you for your confidence in us.

This manual has been written to familiarize you with your lawnmower, to enable you to use it in the best possible conditions and to carry out its maintenance.

Our aim is to make you benefit to the full from technological advances, from new equipment and materials and from our experience. This is why we regularly make improvements to our models. Thus, the specifications and information contained in this manual may be modified without prior notice and without obligation to update it.

If you have a problem, or if you have any questions concerning the lawnmower, contact your supplying dealer or authorized Honda dealer.

Keep this manual handy so you can refer to it at any time. If you sell the lawnmower, be sure that the manual accompanies it.

We recommend that you read the guarantee policy to fully understand your rights and responsibilities. The guarantee policy is a separate document provided by your dealer.

No reproduction, even partial, may be made of this publication without prior written authorisation.

SAFETY INSTRUCTIONS

For your own safety and operating comfort, it is highly recommended that you read this manual in full.

Pay attention to these symbols and their meaning:

WARNING

Indicates a high risk of severe personal injury or death if instructions are not followed.

CAUTION:

• Indicates a possibility of personal injury or equipment damage if instructions are not followed.

NOTE: Source of useful information.

NOTICE

Your lawnmower, other property, or the environment can be damaged if you don't follow instructions.

The purpose of these messages is to help prevent damage to your lawnmower, other property, or the environment.

DESCRIPTION OF THE CODES USED IN THIS MANUAL

HRX537C	H Y E A	V K E A	V Y E A	H Z E A
Hydrostatic drive Selfpropelled	•			•
Self-propelled with variable speed transmission		•	•	
Electric Starter				•
Cutting-means brake		•		
Rotostop	•		•	•

FRAME AND ENGINE SERIAL NUMBER

Record the frame and engine serial numbers (page 3) in the space below. you will need these numbers when ordering parts and when making technical or warranty inquiries.

Frame serial number: _____

Engine serial number: _____

Date of purchase: ____/____/____

Honda France Manufacturing S.A.S. - Pôle 45 - Rue des Châtaigniers
45140 ORMES - FRANCE - All rights reserved



HONDA

OWNER'S MANUAL

(Original instructions)

HRX537C

Pedestrian-controlled lawnmower



Service & Support



<https://www.hondapower.com/fr/>

CONTENTS

FOREWORD	1	MOWING PROCEDURE	11
SAFETY INSTRUCTIONS	1	MOWING TIPS	12
DESCRIPTION OF THE CODES USED IN THIS MANUAL	1	MAINTENANCE	13
FRAME AND ENGINE SERIAL NUMBER	1	THE IMPORTANCE OF MAINTENANCE	13
SAFETY INSTRUCTIONS	2	MAINTENANCE SAFETY	13
SAFETY STICKERS	3	AIR CLEANER MAINTENANCE	14
IDENTIFICATION OF MACHINE	3	ENGINE OIL CHANGE	14
GENERAL DESCRIPTION	4	CHECKING THE SPARK PLUG	14
PREPARATION AND CHECKS		MAINTENANCE OF SPARK ARRESTER (OPTIONAL EQUIPMENT)	15
BEFORE USE	4	CONTROL CABLE ADJUSTMENTS	15
UNPACKING	4	CUTTING MEANS REMOVAL AND INSTALLATION	16
ASSEMBLY OF THE HANDLE	4	GRASS CATCHER CLEANING AND REPLACEMENT	17
CHECKING THE BATTERY (HZEAI)	4	REPLACING A FUSE (HZEAI)	17
CHECKING THE REAR SHIELD	4	OPERATION CHECK OF THE CUTTING MEANS CONTROL	17
CHECKING THE GRASS CATCHER	5	MAINTENANCE SCHEDULE	18
CHECKING FUEL LEVEL	5	TROUBLESHOOTING	18
CHECKING THE AIR CLEANER	5	ENGINE WILL NOT START	18
CHECKING CUTTING MEANS CONDITION	6	LOSS OF POWER	18
ADJUSTING CUTTING HEIGHT	6	VIBRATION	18
CHECKING ENGINE OIL LEVEL	7	MOWING AND GRASS CATCHING PROBLEMS	19
SELECTING THE CUTTING MODE	7	STORAGE	19
STARTING AND STOPPING THE ENGINE	8	TRANSPORT	20
MOWING PRECAUTIONS	8	USEFUL INFORMATION	21
FREQUENCY OF USE	8	FIND AN AUTHORIZED DEALER	21
STARTING THE ENGINE	8	CURRENT PARTS, OPTIONAL ATTACHMENT AND CONSUMABLES	21
STOPPING THE ENGINE	9	TECHNICAL SPECIFICATIONS	21
OPERATING HINTS AND TIPS	10		
USING THE LAWNMOWER AT HIGH ALTITUDES	10		
SAFE MOWING PRACTICES	10		

SAFETY INSTRUCTIONS

For your own safety and operating comfort, it is highly recommended that you read this manual in full.

Pay attention to these symbols and their meaning:

WARNING

Indicates a high risk of severe personal injury or death if instructions are not followed.

CAUTION:

• Indicates a possibility of personal injury or equipment damage if instructions are not followed.

NOTE: Source of useful information.



This sign means that you must take care during certain operations. Refer to the safety instructions on the following pages, to the point(s) indicated in the box.

TRAINING

- A1. Read the instructions carefully. Be familiar with the controls and the proper use before using the equipment. Know how to stop the engine rapidly.
- A2. Use the lawnmower for the purpose it is intended for, that is mowing and collecting grass. Any other use could be dangerous or damage the equipment.
- A3. Never allow children or people unfamiliar with these instructions to use the lawnmower. Local regulations may restrict the age of the operator.
- A4. Never mow when people, especially children or pets are nearby. Never use the machine in cases of fatigue or illness of the user, or after consumption of medications, drugs, alcohol or dangerous substances which might interfere with his ability regarding reflexes and concentration. Never operate the machine if there is a risk of adverse weather such as lightning or a storm, stop operation.
- A5. Keep in mind that the owner or user is responsible for accidents or hazards occurring to other people or their property.
- A6. Never attempt to modify the mower. It can cause an accident as well as damage to the mower. Tampering with the engine voids the EU type-approval of this engine.
 - Do not connect an extension to the muffler.
 - Do not modify the intake system.
 - Do not adjust the governor.
- A7. The machine is equipped with safety devices that must never be modified or removed, otherwise the warranty may be void and the manufacturer released from any liability. Always check that the safety devices work before using the machine.

PREPARATION

- B1. When using the machine, always wear safety shoes that are strong and non-slip and long trousers. Do not use the machine with bare feet or wearing open shoes. Avoid wearing chains, bracelets or baggy clothes with loose parts or with lacing or neck ties. Long hair must be tied back. Always wear an anti-noise helmet.
- B2. Thoroughly inspect the area where the equipment is to be used and remove all objects which may be thrown by the machine (stones, branches, wires, bones, etc...).
- B3. **WARNING** - Petrol is highly flammable.
 - Store fuel in containers specifically designed for this purpose.
 - Refuel outdoors only, before starting the engine and do not smoke while refuelling or handling fuel.
 - Never remove the cap of the fuel tank or add petrol while the engine is running or when the engine is hot.
 - If petrol is spilled, do not attempt to start the engine but move the machine away from the area of spillage and avoid creating any source of ignition until petrol vapours are dissipated.
 - Replace all fuel tanks and container caps securely.
 - Before tipping the lawnmower to maintain the cutting means or drain oil, remove fuel from tank.
- B4. Replace faulty silencers.
- B5. Before use, always visually inspect the machine, especially to see that the cutting means, cutting-means bolts and cutting-means assembly are not worn or damaged. Replace worn or damaged cutting means and cutting-means bolts in sets to preserve balance.

OPERATION

- C1. Do not operate the engine in a confined space where dangerous carbon monoxide fumes can collect.
- C2. Mow only in daylight or in good artificial light. Make sure to comply with legal regulations which may vary from one region to another.
- C3. If there is a risk of adverse weather such as lightning or a storm, stop operation.
- C4. Avoid operating the equipment in wet grass, where possible.
- C5. While mowing, always keep the safety distance to the cutting means, which is provided by the handle length.
- C6. Do not run. Do not let yourself be pulled by the lawnmower.
- C7. Always be sure of your footing on slopes. Mow across the face of slopes, never up and down.
- C8. Keep in mind that the operator or user is responsible for any accidents or unexpected events that may occur to other persons or their property. The user is responsible for checking on possible risks due to the ground to be worked on, and for taking all precautions necessary for ensuring his own safety and that of others, in particular on sloping ground, rough, slippery or unstable terrain, or near holes, ditches or banks.
- C9. Do not mow slopes of more than 20° (36%).
- C10. Use extreme caution when pulling the lawnmower towards you.
- C11. Stop the cutting means if the lawnmower has to be tilted for transportation when crossing surfaces other than grass, and when transporting the lawnmower to and from the area to be mowed.
- C12. Never operate the lawnmower with defective guards or cutting-means enclosures, or without safety devices such as discharge cover and/ or grass catchers.
- C13. Do not change the engine governor settings or overspeed the engine.
- C14. Disengage all cutting-means control (models equipped with Rotostop) and drive clutch (self-propelled models) before starting the engine.
- C15. Start the engine carefully according to instructions and with feet well away from the cutting means.
- C16. Do not tilt the lawnmower when starting the engine. Start the lawnmower on a level surface, free of high grass or obstacle.
- C17. Keep hands and feet away from the rotating parts. Do not start the engine when standing in front of the discharge opening.
- C18. Never pick up or carry a lawnmower while the engine is running.
- C19. Stop the engine and disconnect the spark plug cap in the following cases:
 - Before any operation under the cutting-means enclosure or the discharge chute.
 - Before checking, cleaning or working on the lawnmower.
 - After striking a foreign object. Inspect the lawnmower for damage and make repairs before restarting and operating the lawnmower again.
 - If lawnmower starts to vibrate abnormally. Check immediately the cause of the vibration and perform the necessary repair.
- C20. Stop the engine in the following cases:
 - Whenever you leave the lawnmower unattended.
 - Before refuelling.
- C21. Stop the cutting means (models equipped with Rotostop) or the engine in the following cases:
 - When installing or removing the grass catcher.
 - Before adjusting the cutting height.
- C22. Reduce the throttle setting during engine shut-down. Close the fuel shut-off valve by turning the fuel shut-off valve.
- C23. Using any attachments other than those recommended in this manual may cause damage to your lawnmower, and such damage will not be covered by your guarantee.
- C24. **CAUTION**
The levels for noise and vibration indicated in this manual are the maximum values for using the machine. The use of an unbalanced cutting means, an excessive speed of movement and a lack of maintenance have a significant effect on sound emissions and vibration. It is therefore necessary to take preventive measures to eliminate all possible damage due to high noise levels, and stresses due to vibrations; please ensure that the machine is well maintained, wear an anti-noise helmet. Take breaks during the work.



E

MAINTENANCE AND STORAGE

- D1. Keep all nuts, bolts and screws tight to be sure the equipment is in safe working condition. Regular maintenance is an essential aid to user's safety and retaining a high level of performance.
- D2. Never store the equipment with petrol in the tank inside a building when vapours may reach an open flame, spark or high temperature source.
- D3. Allow the engine to cool before storing in any enclosure.
- D4. To reduce the fire hazard, keep the lawnmower, especially the engine and silencer, the petrol storage area as well, free of grass, leaves, or excessive grease.
Do not leave containers of grass cuttings in or near a building.
- D5. If the fuel tank has to be drained, this should be done outdoors, with a cold engine.
- D6. Check the grass catcher frequently for wear or deterioration.
- D7. Do not use the machine with worn or damaged parts.
Parts must be replaced, not repaired. Replace worn or damaged parts with Honda genuine parts.
Cutting means must always bear the mark Honda and the reference number.
Non equivalent quality parts may damage the machine and be prejudicial to your safety.
- D8. Wear thick gloves when removing or installing the cutting means or when cleaning the cutting-means enclosure.
When tightening or loosening the cutting-means screws, use a wooden block to prevent the cutting means from rotating.
- D9. Always make sure the correct balance of the cutting means when sharpening.

SAFETY STICKERS

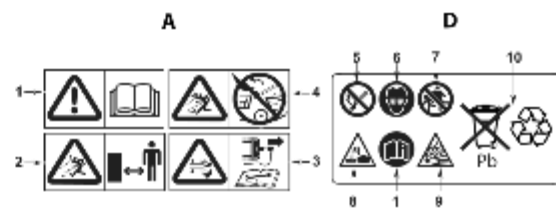
This sticker warns you of potential hazards that can cause serious injury. Carefully read the meaning. If the sticker comes off or becomes hard to read, contact your servicing dealer for a replacement.

Letter	Meaning
A, D	 <p>1. Warning: Read the owner's manual before using the mower. 2. Risk of projections: Keep third persons away from the area during use. 3. Risk of cuts. Rotating cutting means: Do not put hands or feet inside the cutting-means enclosure. Disconnect the spark plug cap before performing any operation of maintenance or repairs. 4. Do not operate without either discharge guard or grass catcher in place. 5. No sparks, flames, smoking. 6. Wear eye protection. 7. Keep out of reach of children. 8. Corrosive substance - Can cause blindness or severe burns. 9. Explosive gases - Shield eyes. 10. Recycle - Contains lead.</p>
B	 <p>11. Warning: Read the owner's manual before using the mower. 12. The engine emits toxic carbon monoxide. Do not run in an enclosed area. 13. Petrol is highly flammable. Stop the engine before refueling.</p>

IDENTIFICATION OF MACHINE

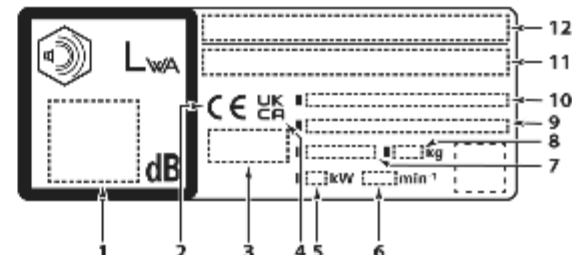
Letter	Meaning
C	 <p>1. Sound power level 2. CE marking 3. Optional conformity mark 4. UK conformity assessed mark (for United Kingdom) 5. Nominal power in kilowatts 6. Recommended engine speed in min^{-1} 7. Month and year of manufacture 8. Mass in kilograms (with empty tanks) 9. Frame serial number (Type and serial number of Declaration of Conformity) 10. Model - Type 11. Authorized representative name and address 12. Name and address of the manufacturer</p>

E

GENERAL DESCRIPTION

HZEA type

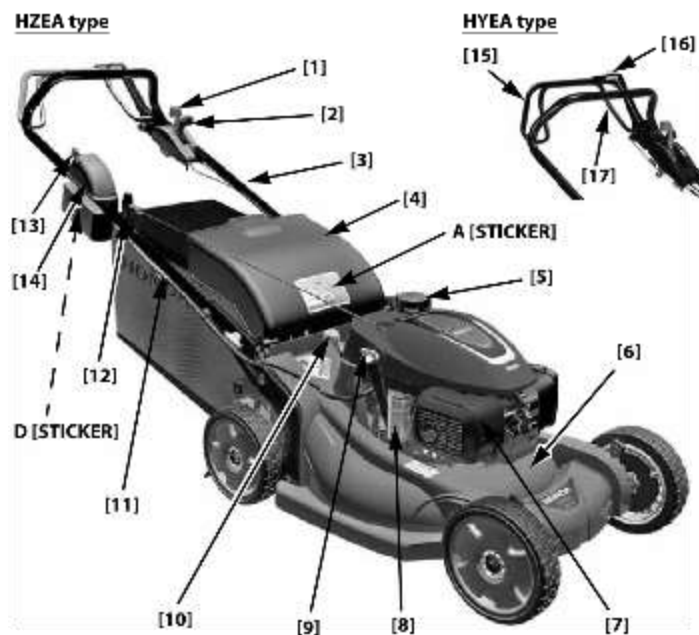

HYEA type

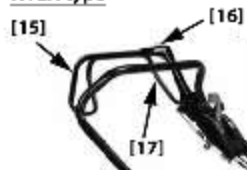

VKEA type

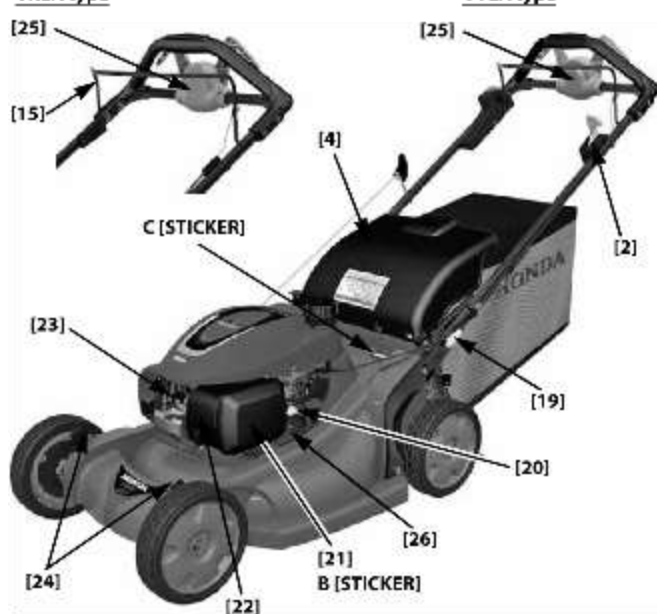

VYEA type



1	Shift lever
2	Throttle lever
3	Handlebar
4	Discharge guard
5	Fuel tank cap
6	Cutting-means enclosure
7	Muffler
8	Electric starter (HZEA only)
9	Oil filler cap
10	Clip Director knob
11	Battery charger connector (HZEA only)
12	Recoil starter
13	Key switch (HZEA only)
14	Battery box (HZEA only)

15	Cutting-means control (Starts and stops the cutting means)
16	Roto-Stop button
17	Drive clutch control (Transmission control which drives the rear wheels)
18	Grass catcher
19	Handlebar adjust knob (2)
20	Fuel valve
21	Air cleaner
22	Carburetor
23	Spark plug cap
24	Cutting height adjustment lever (4)
25	Select Drive control
26	Engine serial number

PREPARATION AND CHECKS BEFORE USE



UNPACKING

Remove all the cardboard from around the handlebar.

ASSEMBLY OF THE HANDLE

1. Turn the handlebar adjust knobs [1] 90 degrees into the unlock position [2].
2. Move the handlebar into the mowing position so that the locating pins align with either the upper, middle, or lower holes on the handlebar mounting brackets.
3. Turn the adjust knobs 90 degrees into the lock position [3] and the pins will snap into the holes and lock into position.

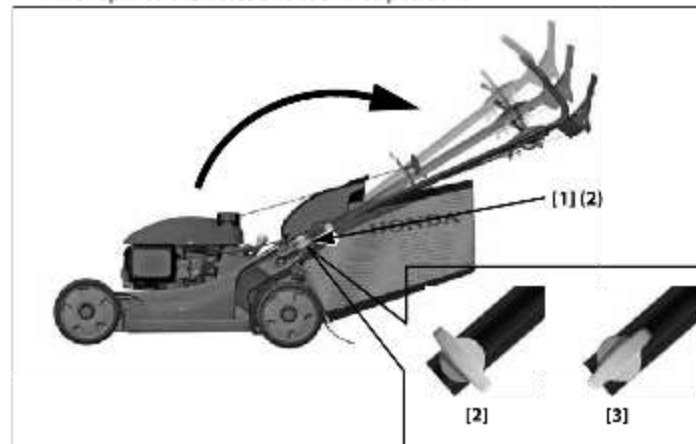

CHECKING THE BATTERY (HZEA)

The lawnmower has an internal charging system. Under normal mowing usage it is not necessary to charge or maintain the battery.

The mower is shipped with the ignition key in the parts bag. Install the key in the key switch.

CHECKING THE REAR SHIELD

During normal use the rear shield [1] is subject to deterioration and wear. Remove the grass catcher [2] and raise the discharge guard [3] to check the rear shield for cracks or tears. If the rear shield is excessively worn, have it replaced by your authorized Honda servicing dealer.

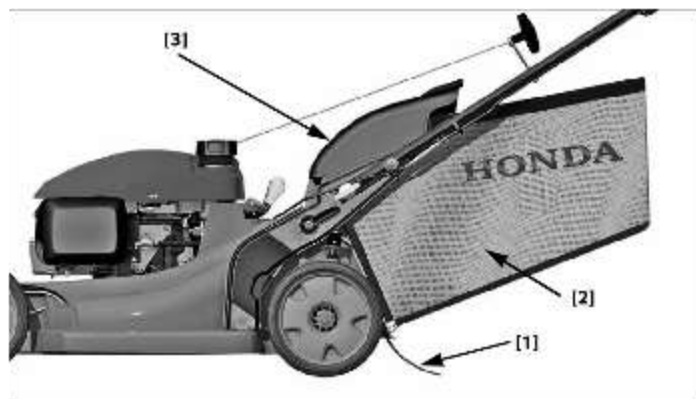

CHECKING THE GRASS CATCHER

1. Slide the grass catcher frame [1] into the grass catcher [2] and install the plastic clips [3] as shown.

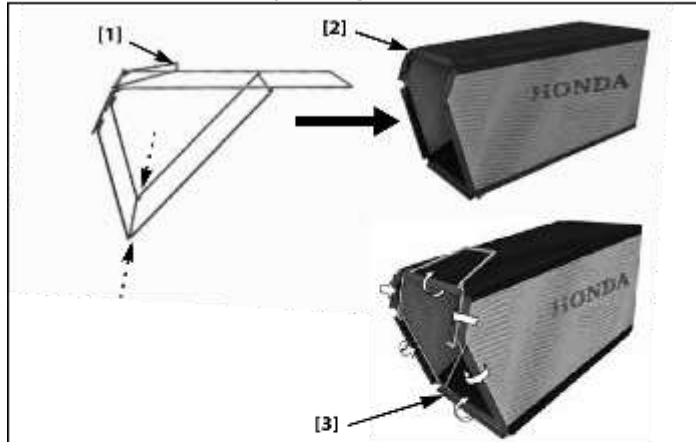

A lawnmower works like a vacuum cleaner; it blows air through the catcher, which traps the grass clippings. Always empty the grass catcher before it becomes filled to the limit of its capacity. Catching performance will diminish after the catcher becomes about 90% filled. Also, the catcher is easier to empty when it is not packed full.

Inspection

During normal use, the grass catcher material is subject to deterioration and wear.

NOTICE

Frequently inspect the grass catcher for tears, holes, and excessive wear. Check for necessary replacement. Make sure the new catcher meets the original specifications.

If the grass catcher needs replacement, you can remove and install a catcher yourself (page 17).

Installation

1. Raise the discharge guard [1], and use the grass catcher handle [3] to hook the grass catcher [2] onto the cutting-means enclosure as shown.
2. Release the discharge guard to secure the grass catcher.

Removal

1. Raise the discharge guard, grasp the grass catcher handle, and remove the grass catcher.
2. Release the discharge guard.
3. When the grass catcher is clear of the discharge guard, you can lift it through the handlebar opening, or you can remove it to the rear of the mower below the handlebar.

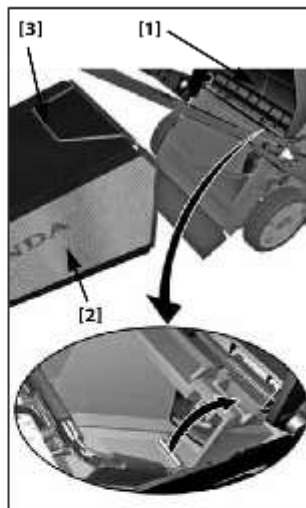

CHECKING FUEL LEVEL

This engine is certified to operate on unleaded petrol with a research octane rating of 91 or higher.

Fuel specification(s) necessary to maintain the performance of the emissions control system: E10 fuel referenced in EU regulation.

We recommend refueling after each use to minimize the air present in the fuel tank.

Refuel in a well-ventilated area before starting the engine. If the engine has been running, allow it to cool. Never refuel the mower inside a building where petrol fumes may reach flames or sparks.

You may use regular unleaded petrol containing no more than 10% ethanol (E10) or 5% methanol by volume. In addition, methanol must



contain cosolvents and corrosion inhibitors. Use of fuels with content of ethanol or methanol greater than shown above may cause starting and/or performance problems. It may also damage metal, rubber, and plastic parts of the fuel system. In addition, ethanol is hygroscopic, which means it attracts and retains water in the fuel system. Engine damage or performance problems that result from using a fuel with percentages of ethanol or methanol greater than shown above are not covered by warranty. Using the fuel indicated above is necessary to maintain the performance of the emission control system.

If your equipment will be used on an infrequent or intermittent basis, (more than 4 weeks before next use) please refer to the *Fuel* section of the STORAGE chapter (page 19) for additional information regarding fuel deterioration.

WARNING

Petrol is highly flammable and explosive.

You can be burned or seriously injured when handling fuel.

- Stop the engine and allow to cool.
- Keep heat, sparks, and flame away.
- Handle fuel only outdoors.
- Wipe up spills immediately.

Never use stale or contaminated petrol or an oil/petrol mixture. Avoid getting dirt or water in the fuel tank.

NOTICE

Fuel can damage paint and plastic. Be careful not to spill fuel when filling your fuel tank. Damage caused by spilled fuel is not covered under warranty.

Remove the fuel tank cap and check the fuel level. Refill the tank if the fuel level is low. Refuel carefully to avoid spilling fuel. Do not overfill; there should be no fuel in the filler neck [1].

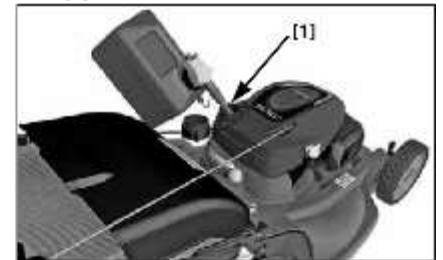

After refueling, tighten the fuel tank cap securely.

Move the mower at least 3 meters away from the fueling source and site before starting the engine.

Fuel Storage Container

Store your petrol in a clean, plastic, sealed container approved for fuel storage. Close the vent (if equipped) when not in use, and store the container away from direct sunlight. If it will take more than 3 months to use the fuel in the container, we suggest adding a fuel stabilizer to the fuel when you fill the container.

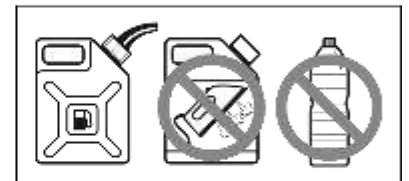

CHECKING THE AIR CLEANER

Remove cover [1]. Make sure the filter [2] is clean and in good condition. A dirty air filter will restrict air flow to the carburetor, reducing engine performance. Refer to page 14 for air cleaner service.

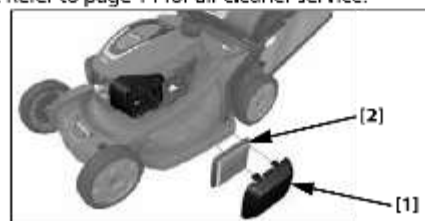

CHECKING CUTTING MEANS CONDITION

1. Stop the engine.
 HYEА, VYEА types:
 Move the throttle lever to the STOP position (page 9).
 HZEА type:
 Turn the key to the OFF position (page 9).
 VKEА type:
 Release the cutting-means control lever [1] to stop the engine and cutting means rotation (page 9).

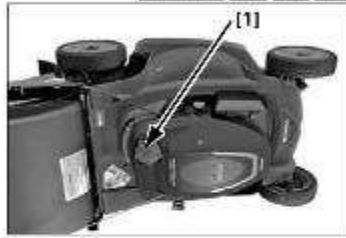

2. Move the fuel valve to the OFF position (page 9).
3. Disconnect the spark plug cap from the spark plug (page 14).
4. Tilt the mower to the right so the fuel cap [1] is up. This will help prevent fuel leakage, motor oil seeping into the air filter, and hard starting.
5. Inspect the cutting means [2] for damage, cracks, and excessive wear, rust, or corrosion.

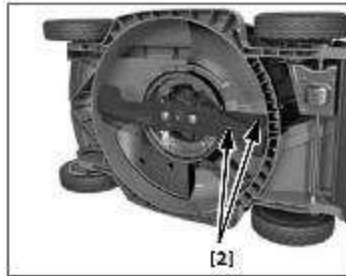

⚠ WARNING

A worn, cracked, or damaged cutting means can break, and pieces of the damaged cutting means can become dangerous projectiles.

Thrown objects can cause serious injury.

Inspect the cutting means regularly, and do not operate the mower with a worn or damaged cutting means.

A dull cutting means can be sharpened, but a cutting means that is worn out, bent, cracked, or otherwise damaged must be replaced. A worn or damaged cutting means can break, causing cutting means pieces to be thrown from the mower.

When a cutting means needs sharpening or replacement, take the lawnmower to an authorized Honda dealer. Or, if you have a torque wrench, you can remove and install the cutting means yourself.

Check that the cutting means bolts are tight (page 16).

ADJUSTING CUTTING HEIGHT

There are seven adjustment settings. The cutting height figures are approximate. The actual height of cut grass will vary with lawn and soil conditions.

Check the cutting-means enclosure cutting height settings, and be sure that both adjustment levers [1] are set to the same cutting height position.

To adjust cutting height, pull each adjustment lever [1] toward the wheel, and move it into another notch.

If you are not sure what cutting height to select, start with a high setting and check the appearance of the lawn after mowing a small area. Then readjust cutting height if necessary.

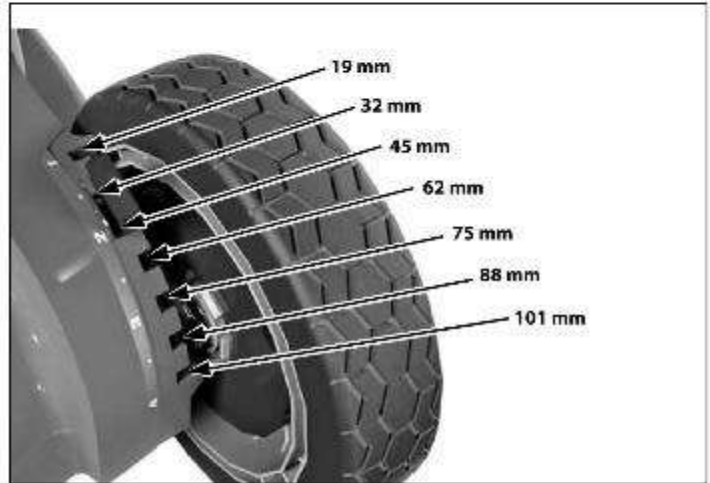

There is one adjustment lever [1] for each wheel.

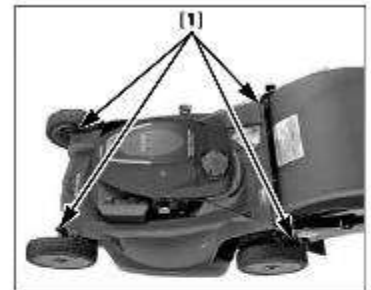

Consult a local nursery or lawn and garden center for cutting height recommendations and advice about specific types of grasses and growing conditions in your area.



If you look closely, you'll see that most grass has stems and leaves. If you cut off the leaves, you'll scalp the lawn. Let the grass recover between mowings. Your mower will work better, and your lawn will look better.



If your grass gets too tall, cut it once at the highest cutting height setting, and then mow again in 2 or 3 days. Don't take off more than one third of total grass height in any one mowing, or brown patches may develop.

CHECK NG ENGINE OIL LEVEL

The mower is shipped **WITHOUT OIL** in the engine.

Add enough SAE 5W-30, 10W-30 API service category SJ or later oil to bring the oil level between the upper limit [2] and lower limit [3] marks on the dipstick [1] as shown.

Do not overfill the engine with oil. If the engine is overfilled, the excess oil may get transferred to the air cleaner housing and air filter.

Check the engine oil level with the engine stopped and the mower on a level surface.

Use 4-stroke motor oil that meets or exceeds the requirements for API service classification SJ or later.

Always check the API service label on the oil container to be sure it includes the letters SJ or later.

SAE 5W-30, 10W-30 is recommended for general use. Other viscosities shown in the chart may be used when the average temperature in your area is within the indicated range.

Lubrication oil specifications necessary to maintain the performance of the emissions control system: Honda genuine oil.

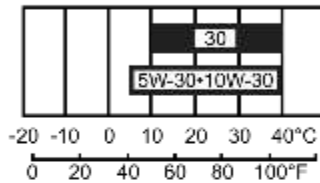

NOTICE

- Running the engine with a low oil level can cause engine damage.
- Using nondetergent oil can shorten the engine's service life, and using 2-stroke oil can damage the engine.

1. Remove the oil filler cap/dipstick [1], and wipe the dipstick clean.
2. Insert the dipstick into the filler neck. Do not screw it down. Remove the dipstick and check the oil level.
3. If the oil level is near the low level mark [3], add the recommended oil to bring the level up to the high limit mark [2]. Do not overfill.
4. Install and tighten the filler cap/dipstick [1] securely.

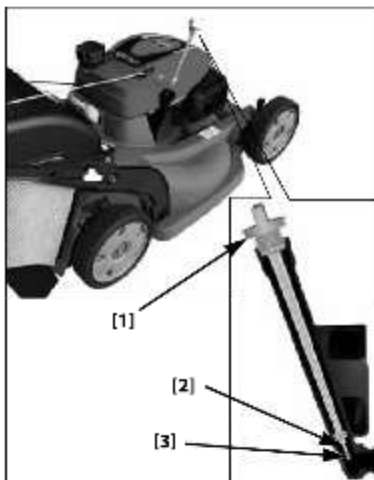

SELECTING THE CUTTING MODE

The Clip Director knob [1] controls grass catching, mulching, and rear discharge. The knob has ten adjustment positions.

Adjust the Clip Director knob [1] in any one of the ten positions to achieve the desired mowing results.

To adjust the Clip Director knob, pull the knob downward and towards the rear of the mower. The knob adjusts a sliding door [2] from the fully open BAG position to the fully closed MULCH position (see the following page).

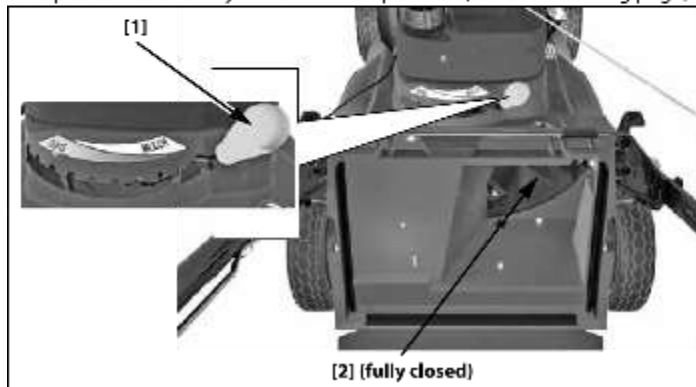

If a high resistance is noticed when moving the Clip Director knob from side-to-side, excessive grass may have built up on top of the sliding door.

Some grass accumulation in the discharge chute is normal when the Clip Director is fully closed. To remove this grass, close the discharge guard, fully open the Clip Director, start the engine, and engage the cutting-means control lever several times.

NOTICE

Always turn the engine off and disconnect the spark plug cap before lifting the discharge guard to view or clean around the sliding door. This will prevent contact with the rotating cutting means and prevent objects from being thrown into the discharge area.

Sliding Door Position

The sliding door [2] can be positioned to produce different mowing results. If the preferred sliding door position is unknown, install a grass catcher and begin mowing with the Clip Director knob [1] all the way to the BAG position. Check the appearance of the lawn. As the knob is moved towards the MULCH position, more grass will be recycled back into the lawn. Adjust the Clip Director knob until the desired result is achieved.

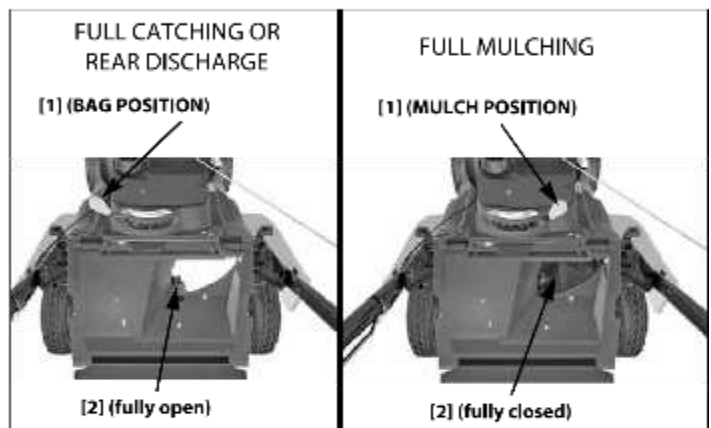
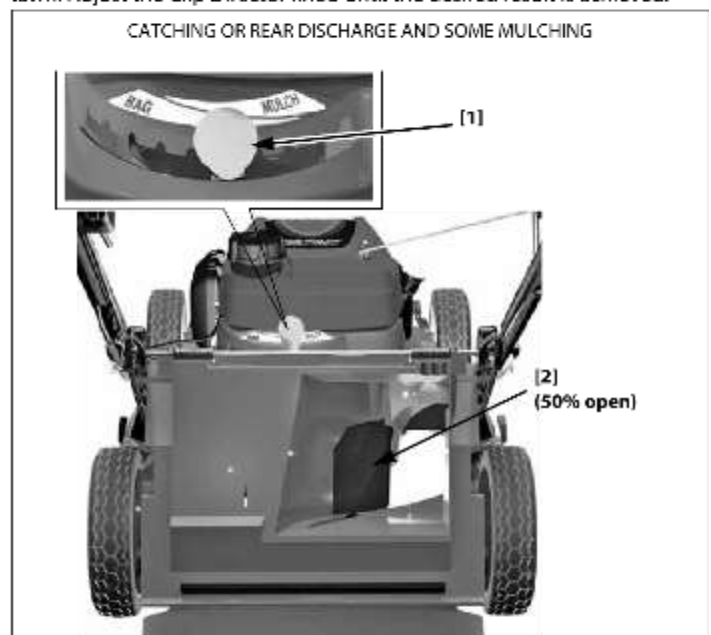

Rear Discharge

To discharge clippings to the rear, remove the grass catcher and position the Clip Director knob [1] in the BAG range.

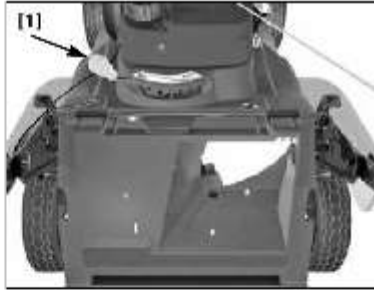

Maximum rear discharge will occur when the Clip Director knob is all the way to the left (BAG) position. As the Clip Director knob is moved toward the right (MULCH) position, less grass will be discharged through the rear discharge guard.



STARTING AND STOPPING THE ENGINE



MOWING PRECAUTIONS

Before operating the mower for the first time, please review *SAFETY INSTRUCTIONS* (page 2) and *PREPARATION AND CHECKS BEFORE USE* (page 4).

Even if you have operated other mowers, take the time to become familiar with how this mower works, and practice in a safe area until you build up your skills.

For your safety, do not start or operate the engine in an enclosed area such as a garage. Your mower can collect rapidly in an enclosed area and cause illness or death.

FREQUENCY OF USE

If your equipment will be used on an infrequent or intermittent basis, (more than 4 weeks before next use) please refer to the *Fuel* section of the *STORAGE* chapter (page 19) for additional information regarding fuel deterioration.

STARTING THE ENGINE

1. Turn the fuel valve [1] to the ON position.

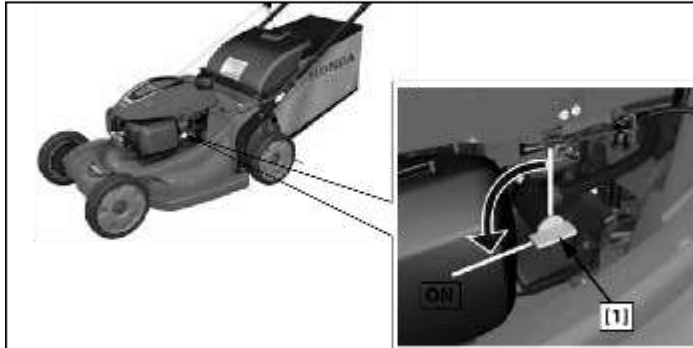

2. HYE, HZE, VYE types:
Move the throttle lever [2] to the FAST (👉) position.

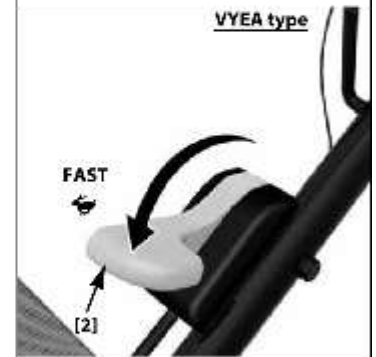
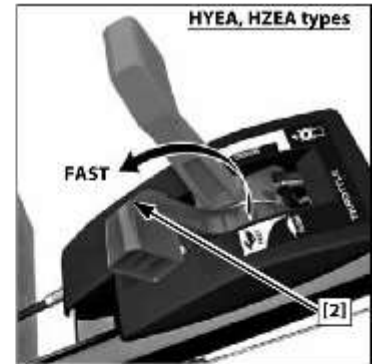

VKE type:

Pull back on the cutting-means control lever and hold it against the handlebar.

The lever must be against the handlebar to start the engine. The cutting means start to rotate when the lever is against the handlebar and the recoil starter grip is pulled.



3. HYE type:

Pull the starter grip [3] lightly until you feel resistance, then pull briskly. Return the starter grip gently.

To keep the cutting means from turning and to prevent the mower from moving forward, always release the cutting-means control lever [4] and drive clutch control [5] when you pull the starter.

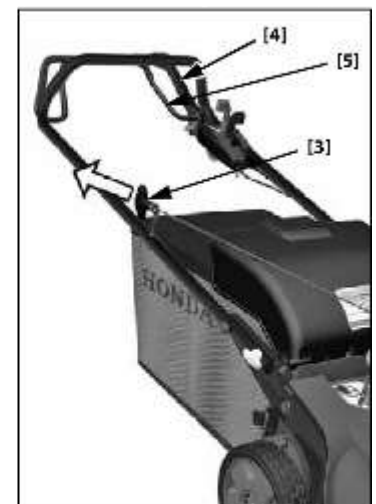

HZEA electric start type:

Turn the starter key switch [6] to the START (🔌) position. Let the key return to the ON (I) position when the engine starts.

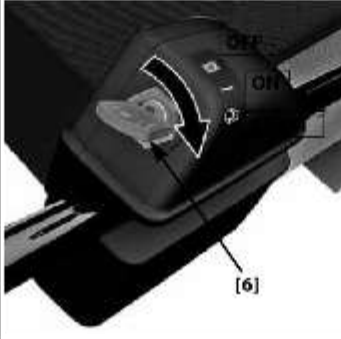
○	OFF	Stops the engine.	
I	ON	Running position (the key switch must be in the ON position to use the recoil starter).	
🔌	START	Operates the electric starter.	

The starter should not be cranked for more than 5 seconds at a time. If the engine fails to start, release the switch and wait 10 seconds before operating the starter again.

If the battery does not have sufficient charge to start the engine, possibly due to a long storage period, use the recoil starter to start the engine for at least one mowing session. The battery should have sufficient charge after one mowing session (approximately 1 hour).

HZEA manual start:

Turn the starter key switch ON. The engine switch must be in the ON (I) position to start the engine with the recoil starter.

Move the throttle lever to the FAST (🔥) position.

Pull the starter grip lightly until you feel resistance, then pull briskly. Return the starter grip gently.



VKEA type:

Pull the starter grip lightly until you feel resistance, then pull briskly. Return the starter grip gently.

Continue to hold the cutting-means control lever against the handlebar; the engine stops when the cutting-means control lever is released.

To ensure easy restarting and maximum performance from the Auto Choke System, start mowing as soon as the engine starts and allow the engine to run for at least three minutes before stopping the engine.

VVEA type:

Pull the starter grip lightly until you feel resistance, then pull briskly. Return the starter grip gently.

To keep the cutting means from turning and to prevent the mower from moving forward, always release the cutting means control lever and Select Drive control when you pull the starter.

- Put the throttle lever [7] in the FAST (🔥) position to mow or to the SLOW (🔻) position to idle.

To ensure easy restarting and maximum performance from the Auto Choke System, start mowing as soon as the engine starts and allow the engine to run for at least three minutes before stopping the engine.

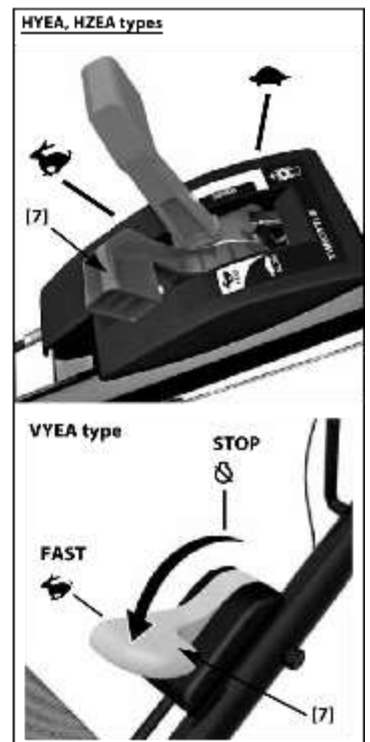

STOPPING THE ENGINE

- HVEA, HZEA types:**

Release the drive clutch control and cutting-means control lever.

VKEA type:

Release the cutting-means control lever [1] to stop the engine and cutting means rotation.



VVEA type:

Release the cutting-means control lever [1] to stop the engine and cutting means rotation. Move the throttle lever [2] to the STOP (🔌) position to stop the engine.

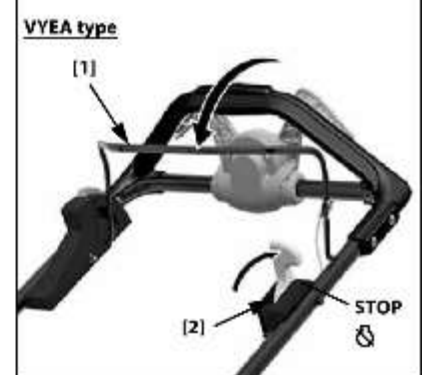

- HVEA type:**

Move the throttle lever [2] to the STOP (🔌) position to stop the engine.

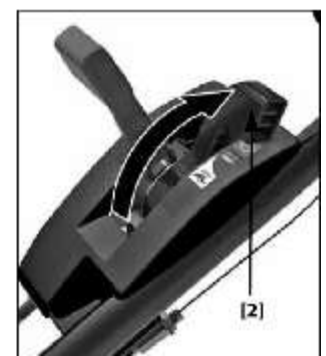

HZEA type:

Move the throttle lever to the STOP position and then turn the key switch [3] to the OFF (O) position.

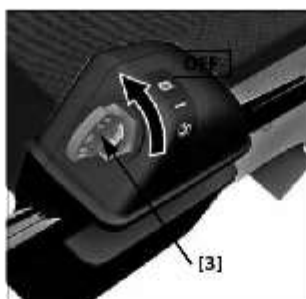

3. When the mower is not in use, turn the fuel valve [4] to the OFF position.

4. If your equipment will not be used for 3 to 4 weeks, we recommend running the engine's carburetor out of fuel. You can do this by leaving the fuel valve OFF, restarting the engine and running it out of fuel. See "Storage" on page 19 for periods of inactivity that exceed 4 weeks.

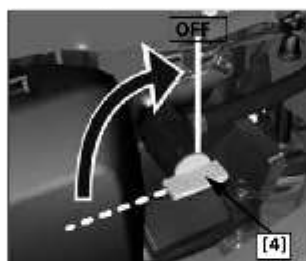

OPERATING HINTS AND TIPS

USING THE LAWNMOWER AT HIGH ALTITUDES

At high altitude, the standard carburetor air-fuel mixture will be too rich. Performance will decrease, and fuel consumption will increase. A very rich mixture will also foul the spark plug and cause hard starting.

High altitude performance can be improved by specific modifications to the carburetor. If you always operate your mower at altitudes above 610 meters, have an authorized Honda dealer perform this carburetor modification.

Even with carburetor modification, engine power will decrease about 3.5% for each 300 meter increase in altitude. The effect of altitude on power will be greater than this if no carburetor modification is made.

NOTICE

When the carburetor has been modified for high altitude operation, the air-fuel mixture will be too lean for low altitude use. Operation at altitudes below 610 meters with a modified carburetor may cause the engine to overheat and result in serious engine damage. For use at low altitudes, have your authorized Honda dealer return the carburetor to original factory specifications.

SAFE MOWING PRACTICES

For your safety, keep all four wheels on the ground, and be careful to avoid losing your footing and your control of the mower. Keep a firm grip on the handlebar, and walk, never run, with the mower. Be very careful when mowing uneven or rough ground.

If stuck, do not kick or shove the mower with your foot. Use the handlebar to control the mower.

WARNING

The cutting means are sharp and spin at high speed.

If you come in contact with a spinning cutting means, it will cut you severely and can amputate fingers and toes.

- Wear protective footwear.
- Keep your hands and feet away from the cutting-means enclosure while the engine is running.
- Stop the engine before performing any adjustment, inspection, or maintenance.

Stability

Mow across slopes, not up and down. Avoid steep slopes (more than 20° (36%)), and be careful when changing direction. Mowing on a slope when the grass is damp or wet could cause you to slip, fall, and lose control of the mower.

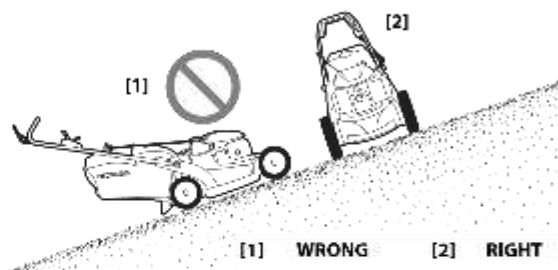

Obstacles

Use the side of the mower to cut close to large obstacles, such as fences or walls.

Release the drive clutch control (HYEA, HZEA types) or Select Drive control (VKEA, VYEA types) to disengage the drive when mowing around trees and other obstacles. Push the mower around obstacles for better directional control. Be careful when mowing over obstacles embedded in the lawn, such as sprinkler heads, paving, edging, etc. Avoid anything that sticks up above the surface of the lawn.

If the cutting means hits something, or if the mower starts to vibrate, stop the engine immediately and check for damage. Striking objects may damage the cutting means, bend the crankshaft, and/or break the cutting-means enclosure or other components. Vibration usually indicates serious trouble.

WARNING

A worn, cracked, or damaged cutting means can break, and pieces of the damaged cutting means can become dangerous projectiles.

Thrown objects can cause serious injury.

Inspect the cutting means regularly, and do not operate the mower with a worn or damaged cutting means.

The warranty does not cover parts damaged by accident or collision.

Gravel and Loose Objects

Gravel, loose stones, and landscaping material can be picked up by the mower and thrown many feet with enough force to cause serious personal injury and/or property damage. The best way to prevent potential injury from thrown objects is to release the cutting-means control lever to stop the cutting means before reaching areas with gravel, loose stones, or landscaping material.

MOWING PROCEDURE



Read the safety instructions before starting to mow.



HYEA, HZEA types

WARNING

Always release the cutting-means control lever and the drive clutch lever before starting the engine. Starting is more difficult when the cutting means is engaged. If drive clutch is engaged, the lawnmower will move when the engine is started.

1. Select the suitable forward speed with the shift lever [1].

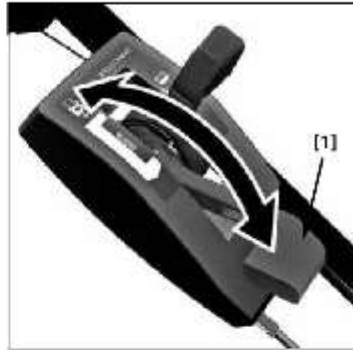

2. Engage the cutting means:
 - Press the yellow button [2] located on the top of the cutting-means control lever [3], and at the same time push it quickly and hold it against the handle.

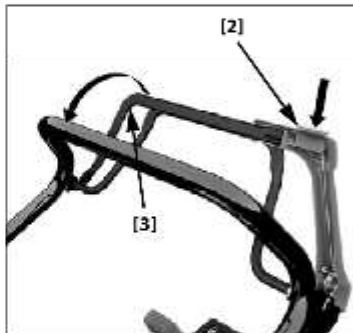

3. Engage lawnmower forward drive when the motor has picked up speed:
 - The drive clutch lever [4] acts as a variable speed control according to its squeezed position. It makes the speed vary between zero and the maximal speed preset with the shift lever. The maximum speed can be reached when both levers [3] and [4] are pushed forward completely.

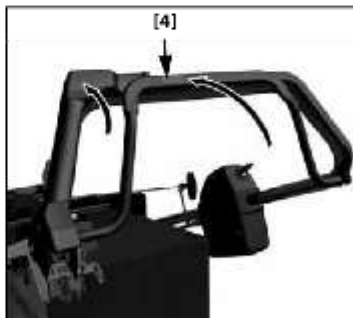

The greater the height of the grass to be cut, the more it is necessary to reduce the drive speed of the machine. This will prevent overloading the engine and improve the quality of the cut.

4. To stop the lawnmower moving forward:
 - Release the drive clutch lever [4].
5. To stop the cutting means rotating:
 - Release the cutting-means control lever [3].

NOTE: It is possible to refrain from using the forward drive while mowing in areas with a narrow surface (lanes, borders, etc.). The drive clutch can be used to move the lawnmower without engaging the cutting-means control.

CAUTION:

- Move the cutting-means control lever quickly from one end of its travel to the other, so that the cutting means is always either fully engaged or fully disengaged. This is to avoid stalling the engine and increases the service life of the cutting-means control mechanism.

VKEA type:

1. With the engine running and the cutting means rotating, slowly push the Select Drive control [5] to propel the mower forward.
2. Normal operation is with your hand comfortably around the handle bar [6] and Select Drive control [5] with the Select Drive control being flush with the handle bar [6].
3. Should the mower not move forward, additional power may be required which can be achieved by adjusting the Select Drive control knob [7] in the "+" direction.
4. Once you have achieved your preferred mowing speed by pushing down the Select Drive control [5] in combination with the appropriate Select Drive control knob [7] setting, you can commence mowing at your preferred constant speed.
5. Push the Select Drive control [5] with your thumbs into the indentation for boost operation when additional power is required to maintain your desired mowing speed (for example, when encountering a slope or other change in ground conditions).
Once the terrain or ground conditions return to normal, you simply release the boost.

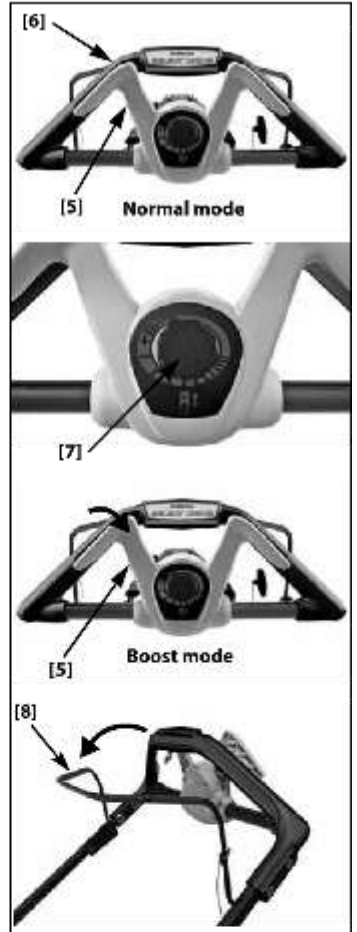

NOTE: The Select Drive control knob [7] allows you to adjust the level of power used to propel the mower. The adjustment range is from "-" to "+" power. The level of power required to achieve a preferred ground speed is dependent upon the combination of terrain conditions, grass conditions and your preferred mowing speed.

6. To stop the lawnmower moving forward:
 - Release the Select Drive control [5].
7. To stop the cutting means rotating:
 - Release the cutting-means control lever [8].

NOTE: Releasing the cutting-means control lever stops the cutting means rotating and stops the engine.

VYEA type:

⚠ WARNING

Always release the cutting-means control lever and the Select Drive control before starting the engine. Starting is more difficult when the cutting means is engaged. If the clutch is engaged, the lawnmower will move when the engine is started.

- Engage the cutting means:
 - Press the unlocking knob [9] and keep it pressed.
 - Pull the cutting-means control lever [10] towards you.
 - Release the unlocking knob [9] when the cutting means are engaged.
- With the engine running and the cutting means rotating, slowly push the Select Drive control [11] to propel the mower forward.
- Normal operation is with your hand comfortably around the handle bar [4] and Select Drive control [11] with the Select Drive control being flush with the handle bar [12].
- Should the mower not move forward, additional power may be required which can be achieved by adjusting the Select Drive control knob [13] in the "+" direction.
- Once you have achieved your preferred mowing speed by pushing down the Select Drive control [11] in combination with the appropriate Select Drive control knob [13] setting, you can commence mowing at your preferred constant speed.
- Push the Select Drive control [11] with your thumbs into the indentation for boost operation when additional power is required to maintain your desired mowing speed (for example, when encountering a slope or other change in ground conditions). Once the terrain or ground conditions return to normal, you simply release the boost.

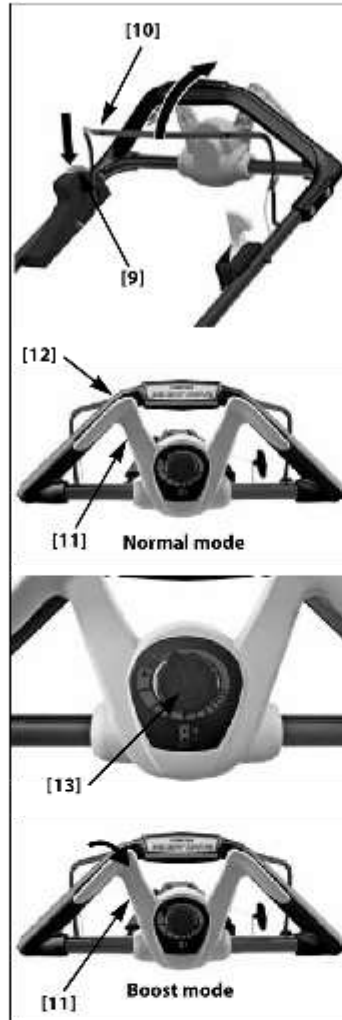

NOTE: The Select Drive control knob [13] allows you to adjust the level of power used to propel the mower. The adjustment range is from "-" to "+" power. The level of power required to achieve a preferred ground speed is dependent upon the combination of terrain conditions, grass conditions and your preferred mowing speed.

- To stop the lawnmower moving forward:
 - Release the Release the Select Drive control [11].
- To stop the cutting means rotating:
 - Release the cutting-means control lever [10].

NOTE: It is possible to refrain from using the forward drive while mowing in areas with a narrow surface (lanes, borders, etc.). Likewise, the Select Drive control can be used to move the lawnmower without engaging the cutting-means control.

CAUTION:

- Move the cutting-means control lever quickly from one end of its travel to the other, so that the cutting means is always either fully engaged or fully disengaged. This is to avoid stalling the engine and increases the service life of the cutting-means control mechanism.

MOWING TIPS

When to Mow

Most grasses should be mowed when they have grown 12 ~ 25 mm above their recommended height.

More frequent mowing is required for mulching than for catching. For best results, you may need to mow the lawn twice a week during the growing season.

Cutting Width

For an even lawn finish, overlap each mowing swath by a few centimeters. If the grass is very tall or thick, use more overlap and a narrower mowing swath.

Cutting Means Speed

The cutting means must spin very fast to cut properly. Always use the fast throttle setting, and keep the engine running at maximum speed.

If engine speed drops, it could mean the engine is being overloaded by the cutting means trying to cut too much grass. Mow a narrower swath, move the mower slower, or raise the cutting height.

Cutting Means Sharpness

A sharp cutting means cuts cleanly. A dull cutting means tears the grass, leaving shredded ends that turn brown. When your cutting means doesn't cut cleanly anymore, have it sharpened or replaced.

Dry Grass

If the ground is too dry, mowing will stir up a lot of dust. Besides being unpleasant to work in, too much dust will clog the carburetor air filter.

If dust is a problem, water your lawn the day before mowing. Mow when the grass is dry to your touch, but the soil is still moist.

Wet Grass

Wet grass is slippery and can make you lose your footing. Also, wet grass clippings will clog the cutting-means enclosure and collect in clumps on the lawn. Always wait for wet grass to dry before mowing.

Fallen Leaves

Your mower can be used to pick up fallen leaves for disposal. If using the mower to catch large amounts of fallen leaves, and not for mowing, set the cutting height adjustment levers so the front of the cutting-means enclosure is one or two settings higher than the rear. To start, position the Clip Director knob in the #9 position (not quite full mulching). This setting will allow the leaves to be recirculated and recut until the particles are small enough to pass through the sliding door opening and into the grass catcher. Mulching when leaves are damp will reduce the amount of dust that is created.

Depending on the size, type, and water content of the leaves, it may be necessary to open the sliding door to allow for best catching results. Using the sliding door correctly will allow better grass catcher filling, resulting in less grass catcher emptying. Be sure there are no obstacles, including rocks, hidden under the leaves.

If you want to mulch fallen leaves into your lawn, don't let the leaf cover get too deep before you begin. For best results, start mulching while grass still shows through the leaf cover. Position the Clip Director knob in the MULCH position. In places where fallen leaves completely cover the grass, remove the leaves by raking, or use the grass catcher so your mower can pick them up for disposal.

Clogged Cutting-means Enclosure

Before clearing a clogged cutting-means enclosure, stop the engine and turn the fuel valve to the OFF position. With the spark plug cap disconnected, tilt the mower so the air cleaner side is up.

Clear a clogged cutting-means enclosure with a stick, not your hands.

Mowing Patterns

Your Honda mower will work most efficiently if you use the following mowing patterns as much as possible. Cutting-means enclosure and equipment design, and the direction in which the cutting means rotate, cause these mowing patterns to give the best results.

Mulching

Use a counterclockwise mowing pattern when the Clip Director knob is in the full MULCH position. If the lawn has an irregular shape, or many obstacles, divide it into sections where you can use counterclockwise mowing patterns.

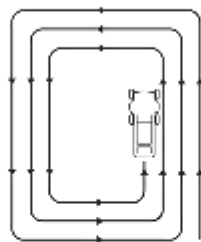

MULCHING PATTERN

Catching

Use a clockwise mowing pattern. This will give the best Clip Director and catching performance, leaving the least amount of clippings on the lawn.

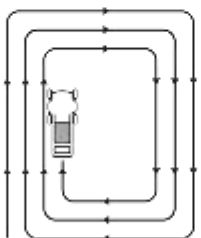

CATCHING &
REAR-DISCHARGE PATTERN

Rear Discharge Mowing

Remove the grass catcher and close the discharge guard. Adjust the Clip Director knob to the desired setting and begin mowing in a clockwise mowing pattern. If the lawn has an irregular shape, or many obstacles, divide it into sections.

MAINTENANCE



⚠ WARNING

To avoid the lawnmower starting accidentally, pull off the spark plug cap [1] before carrying out maintenance work.

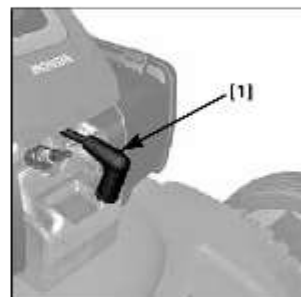

THE IMPORTANCE OF MAINTENANCE

Good maintenance is essential for safe, economical, and trouble-free operation. It will also help reduce air pollution and ensure the emissions performance of the engine continues to be met.

To help you properly care for your mower, the following pages include a maintenance schedule, routine inspection procedures, and simple maintenance procedures using basic hand tools. Other service tasks that are more difficult, or require special tools, are best handled by professionals and are normally performed by a Honda technician or other qualified mechanic.

The maintenance schedule applies to normal operating conditions. If you operate your mower under unusual conditions, consult an authorized Honda dealer for recommendations applicable to your individual needs and use.

Remember that your servicing dealer knows your mower best and is fully equipped to maintain and repair it.

To ensure the best quality and reliability, use only new, Honda Genuine parts or their equivalents for repair and replacement.

⚠ WARNING

Improper maintenance, or failure to correct a problem before operation, can cause a malfunction in which you can be seriously hurt or killed.

Always follow the inspection and maintenance recommendations and schedules in this owner's manual.

MAINTENANCE SAFETY

Some of the most important safety precautions follow. However, we cannot warn you of every conceivable hazard that can arise in performing maintenance. Only you can decide whether or not you should perform a given task.

⚠ WARNING

Failure to properly follow maintenance instructions and precautions can cause you to be seriously hurt or killed.

Always follow the procedures and precautions in this owner's manual.

AIR CLEANER MAINTENANCE

A properly maintained air filter will help prevent dirt from entering your engine. Dirt entering the carburetor can be drawn into small passages in the carburetor and cause premature engine wear. These small passages can become blocked, causing starting or running problems. Always use an air filter specified for your engine to ensure it seals and performs as designed. You will need to clean the filter more frequently if you operate the engine in very dusty conditions.

NOTICE

Operating the engine without an air filter, or with a damaged filter, will allow dirt to enter the engine, causing rapid engine wear. This type of damage is not covered by the warranty.

1. Press down on the air cleaner cover [1] tabs, and then remove the cover.
2. Remove the filter [2] from the air cleaner housing [3].
3. Inspect the filter, and replace it if it is damaged.
4. Clean the filter by tapping the filter several times on a hard surface to remove dirt, or blow compressed air (not exceeding 207 kPa) through the filter from the inside. Never try to brush off dirt; brushing will force dirt into the fibers.
5. Wipe dirt from the inside of the air cleaner housing and cover, using a moist rag. Be careful to prevent dirt from entering the air duct that leads to the carburetor.
6. Reinstall the filter and cover.

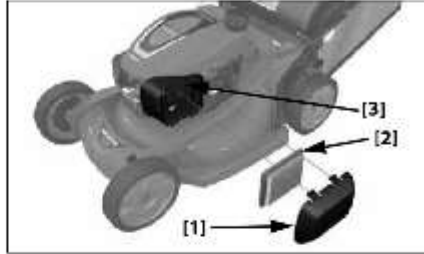

ENGINE OIL CHANGE

Drain the oil while the engine is warm. Warm oil drains quickly and completely.



1. HVEA, VVEA types:

Put the throttle lever in the STOP position and turn the fuel valve OFF. This will reduce the possibility of fuel leakage (page 7).

HVEA type:

Turn the key OFF and turn the fuel valve OFF. This will reduce the possibility of fuel leakage (page 7).

VKEA type:

Turn the fuel valve OFF. This will reduce the possibility of fuel leakage (page 7).

2. Wipe the oil filler area clean, and then remove the oil filler cap/dipstick.

3. Place a suitable container next to the mower to catch the used oil, and then tilt the mower on its right side. The used oil will drain through the filler neck. Allow the oil to drain completely.

Please dispose of used motor oil and the containers in a manner that is compatible with the environment. We suggest you take it in a sealed container to your local recycling center or service station for reclamation. Do not throw it in the trash, pour it on the ground or pour it down a drain.



4. Fill with the recommended oil (page 7).

Refill amount: 0.35 ~ 0.40 L

- 1 Do not overfill. Measure the oil level as shown.



5. After changing the engine oil and before starting the engine, check the oil level with the mower on a level surface:

- a. Remove the filler cap/dipstick [1].
- b. Wipe the dipstick clean.
- c. Insert and remove the dipstick without screwing it into the filler neck. Check the oil level shown on the dipstick.
- d. If the oil level is below the low level mark [3], add oil to reach the high limit mark [2] on the dipstick. Do not overfill. If the engine is overfilled, the excess oil may get transferred to the air cleaner housing and air cleaner filter.

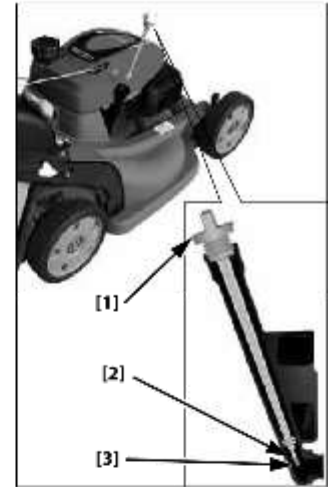

NOTICE

Running the engine with a low oil level can cause engine damage.

- e. Screw in the filler cap/dipstick securely.

CHECKING THE SPARK PLUG

Required spark plugs: NGK - BPR5ES

NOTICE

Incorrect spark plugs can cause engine damage.

For good performance, the spark plug [1] must be properly gapped and free of deposits.

1. Disconnect the spark plug cap [2], and remove any dirt from around the spark plug area.
2. Remove the spark plug with a spark plug wrench.
3. Inspect the spark plug. Replace it if the electrodes are worn or if the insulator is cracked or chipped. Clean the spark plug with a wire brush if you are going to reuse it.

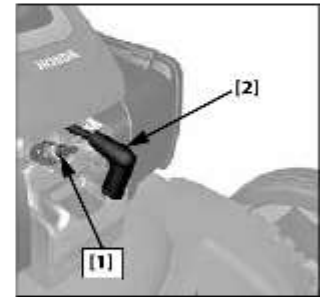

4. Measure the spark plug electrode gap with a suitable gauge. The gap should be 0.7 ~ 0.8 mm. Correct the gap, if necessary, by carefully bending the side electrode.
5. Install the spark plug carefully, by hand, to avoid cross-threading.
6. After the spark plug seats, tighten with a spark plug wrench to compress the washer.

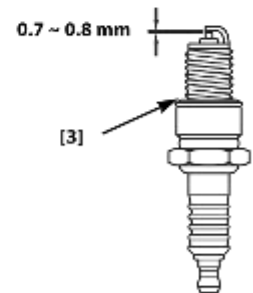

If reinstalling the old spark plug, tighten 1/8 to 1/4 turn after the spark plug seats.

If installing a new spark plug, tighten 1/2 turn after the spark plug seats to compress the washer [3].

TORQUE: 20 N•m

NOTICE

A loose spark plug can overheat and damage the engine. Overtightening the spark plug can damage the threads in the cylinder head.

7. Install the spark plug cap onto the spark plug.

MAINTENANCE OF SPARK ARRESTER (OPTIONAL EQUIPMENT)

In Europe and other countries where machinery directive 2006/42/EC is enforced, this cleaning should be done by your servicing dealer.



The spark arrester must be serviced every 100 hours to keep it functioning as designed.

1. Allow the engine to cool.
2. Unclip the two red top cover tabs [6] on the muffler side of the engine, and then slightly lift the red top cover up to expose the upper muffler shield bolt [1].
3. Remove the three bolts [1] from the muffler shield [2] using a 10 mm socket wrench.
4. Remove the muffler shield [2].
5. Remove the set screw [4].
6. Remove the spark arrester [3] from the muffler [5].
7. Check for carbon deposits on the spark arrester and the exhaust port. Brush carbon deposits away. Be careful to avoid damaging the spark arrester screen.
8. Install the spark arrester into the muffler.
9. Install the muffler shield on the engine, and tighten the three bolts securely, and then reattach the red top cover.

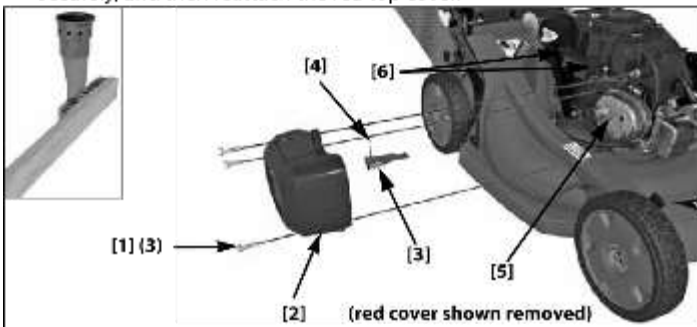

CONTROL CABLE ADJUSTMENTS

Cutting-means Control Cable (HYEA, HZEA)

Measure free play at the top of the cutting-means control lever [1], while holding the button [2] down. Free play should be 10 ~ 15 mm. If adjustment is necessary:

1. Loosen the locknuts [3] with a 10 mm wrench, and move the adjuster [4] up or down as required.
2. Tighten the locknuts and recheck free play.
3. Start the engine outdoors, and operate the cutting-means control lever.

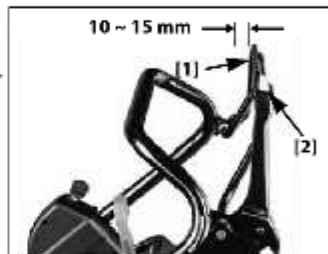

If the cutting means does not start or stop as it should, with correct cable adjustment, take the mower to an authorized Honda dealer for repair.

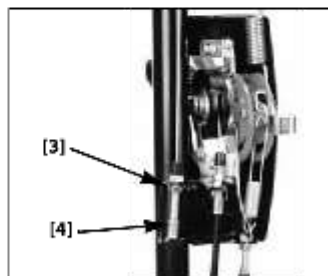

Drive Clutch Cable Adjustment (HYEA, HZEA)

1. With the engine stopped, position the control cable bands [1] as shown.
2. Pull the shift lever all the way back to the slow position.
3. Start the engine and move the throttle lever to the FAST position.

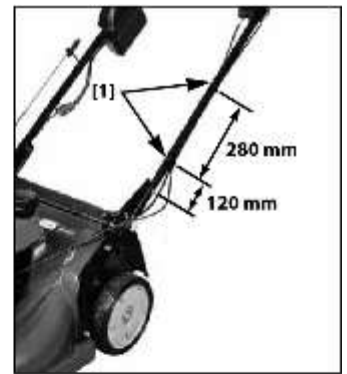

4. Engage the drive clutch control [2] and confirm the following:
 - a. Mower does not self-propel.
 - b. Mower begins to self-propel or creeps very slowly forward when the shift lever is moved one notch forward.

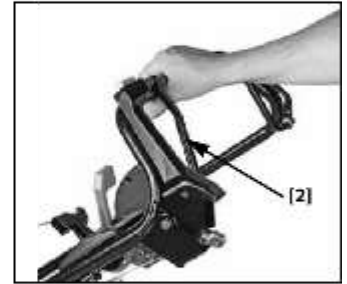

If the mower does not operate as outlined above, go to step 5. If the mower does operate as outlined above, adjustment is not required.

5. Loosen the top [3] and bottom [4] drive clutch cable locknuts with a 10 mm wrench. Move the adjuster [5] up or down, as required, until the mower operates as outlined in step 4. Tighten the locknuts.

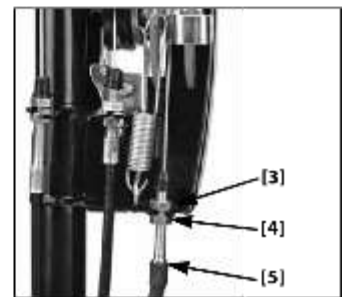

Select Drive Cable Adjustment (VKEA, VYEA)

With the engine off, loosen the jam nut [1] one revolution.

With the Select Drive control released, TIGHTEN [4] the adjuster by turning clockwise 1 revolution by hand, and then pull the lawnmower rearward to check resistance.

If no wheel resistance exists, repeat the above procedure until the wheels lock when pulling rearward. It will usually take more than 8 turns for the wheels to lock up.

Next, use the adjuster mark [3] and LOOSEN [2] the adjuster counterclockwise 8 complete revolutions.

Hold the adjuster and tighten the lock nut against the adjuster. Push the lawnmower forward and pull backward and check for little or no resistance.

Start the engine to ensure the lawnmower does not move forward without pushing the Select Drive control.

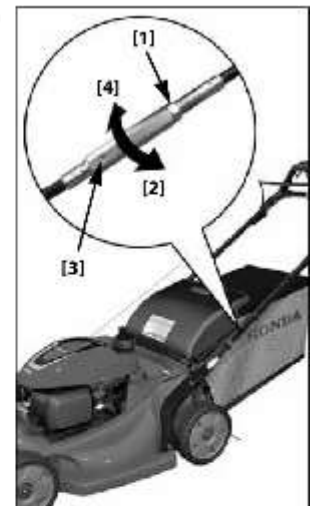

CUTTING MEANS REMOVAL AND INSTALLATION

If you remove the cutting means for sharpening or replacement, you will need a torque wrench for installation. Wear heavy gloves to protect your hands.

CUTTING MEANS SHARPENING: To avoid weakening the cutting means, or causing imbalance or poor cutting, the cutting means should be sharpened by trained staff at an authorized Honda dealer.

CUTTING MEANS REPLACEMENT: Use Honda Genuine replacement cutting means or their equivalent.

Removal

- HYEA, VYEA types:**
Put the throttle lever in the STOP position. Turn the fuel valve OFF and disconnect the spark plug cap.
- HZEA type:**
Turn the key to the OFF position. Turn the fuel valve OFF and disconnect the spark plug cap.
- VKEA type:**
Turn the fuel valve OFF and disconnect the spark plug cap.
- Tilt the mower to the right so the fuel cap is up. This will help prevent fuel leakage, motor oil seeping into the air filter, and hard starting.

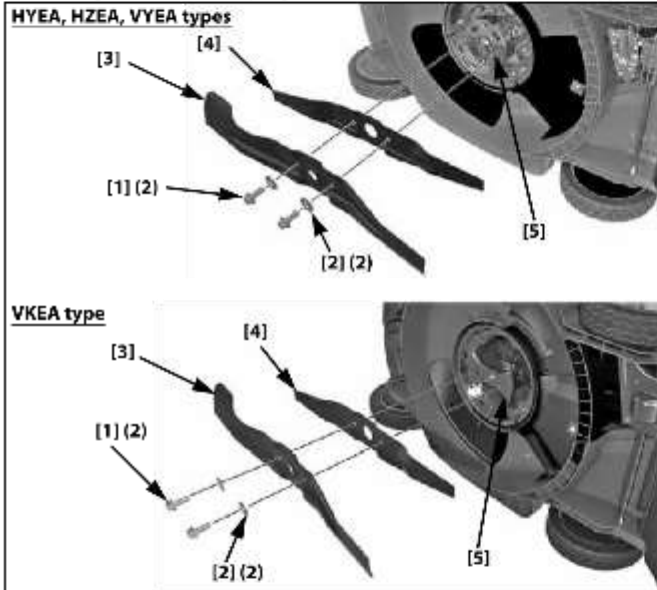

- Use a 14 mm (6 point) socket wrench and remove the two cutting-means bolts [1] and special washers [2] from the cutting-means control assembly [5]. Use a wooden block to prevent the cutting means from turning when removing the bolts.
- Remove the upper [4] and lower cutting means [3].



Installation

- Clean dirt and grass from around the cutting means mounting area.
- Install the cutting means [3] and [4] using the two cutting-means bolts [1] and special washers [2] as shown.

WARNING

Operating this mower with only one cutting means will result in an improperly seated cutting means that can be thrown from the mower and seriously hurt or kill someone. Always use both cutting means as a set.

Be sure to install the special washers with the concave side toward the cutting means and the convex side toward the head of the bolt.

The cutting-means bolts are specially designed for this application and must not be replaced with other bolts.

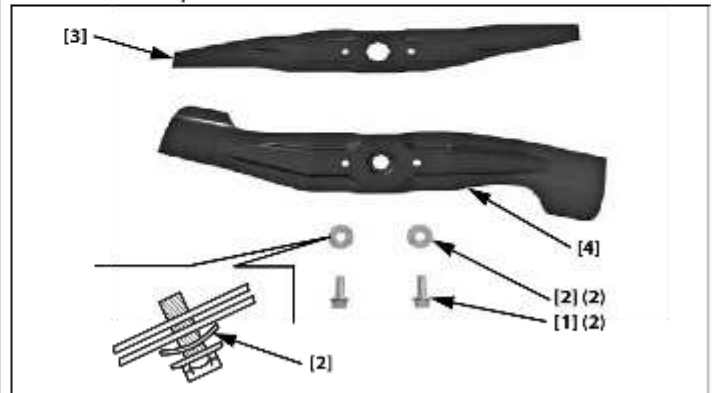

- Tighten the cutting-means bolts [3][4] with a torque wrench [5]. Use a wooden block [6] to prevent the cutting means from turning.

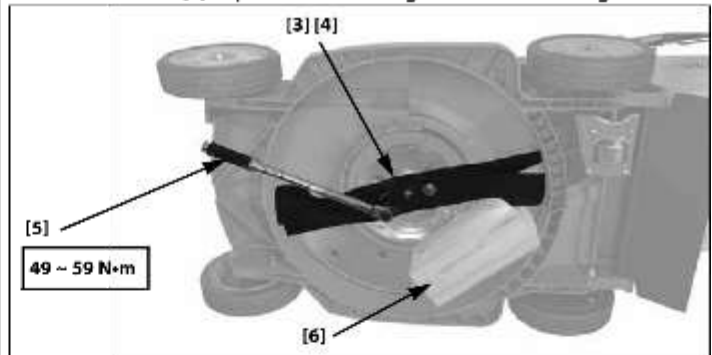

Cutting-means bolt torque: 49 ~ 59 N·m

If you do not have a torque wrench, have an authorized Honda dealer tighten the cutting-means bolts before you use the mower. If the cutting-means bolts are overtightened, they could break. If the cutting-means bolts are not tightened enough, they could loosen or come out. In either case, it would be possible for the cutting means to fly off while you are operating the mower.

Cutting-means Mounting Bolt Inspection

Inspect the cutting-means bolts for any signs of damage or looseness. If they are damaged, they must be replaced.

If they appear loose, a torque wrench must be used to accurately tighten the cutting-means bolts to the required torque. If you do not have a torque wrench, take your lawnmower to an authorized dealer to have the bolts replaced or tightened.

Use only Honda Genuine cutting-means bolts and special washers, since they are specifically designed for this purpose. Replacement part numbers are on page 21.

Inspect washers and bolt heads for looseness and damage.



Cutting-means Replacement

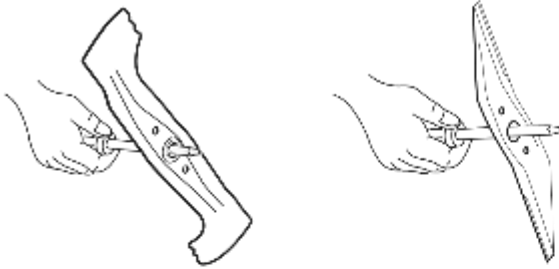

CAUTION:

- Cutting-means balance is critical to proper lawnmower performance. Replace any cutting means that is damaged or out of balance.
- Use only genuine Honda replacement cutting means.

Cutting-means Sharpening

CAUTION:

- To avoid weakening the cutting means, causing it to become unbalanced or getting a bad quality of cut, the cutting means should be sharpened by competent personnel at your servicing dealer.

1. Sharpen the cutting means cutting edges with a file. File the top side only. Maintain the original bevel for a fine cutting edge. File both ends evenly to maintain cutting-means balance.
2. After sharpening, test the cutting-means balance using a screwdriver as shown above. If either side dips slightly below the horizontal, file that side. Replace the cutting means if it dips excessively.

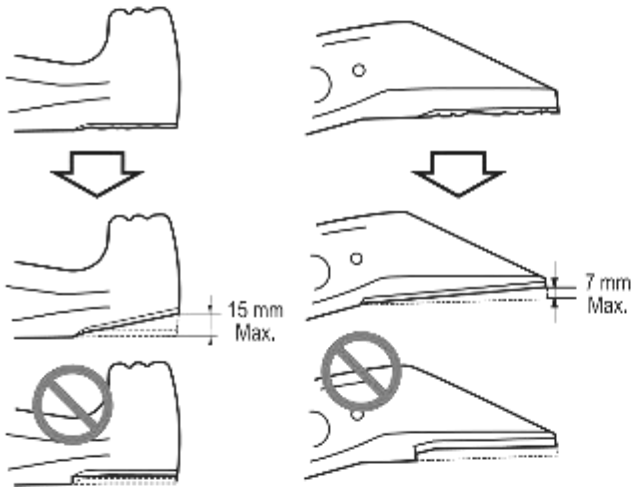

GRASS CATCHER CLEANING AND REPLACEMENT

Cleaning

Wash the catcher with a garden hose, and allow it to dry completely before use; a wet catcher will clog quickly.

Replacement

Replace a worn or damaged catcher with a Honda replacement catcher or its equivalent.

Removal

1. Unclick the plastic edges [1] of the catcher [2] from the frame [3].
2. Remove the catcher from the frame.

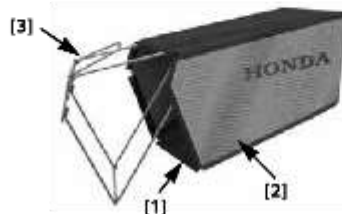

Installation

1. Insert the catcher frame [3] into the catcher [2], as shown above.
2. Clip the plastic edges [1] of the catcher onto the frame.

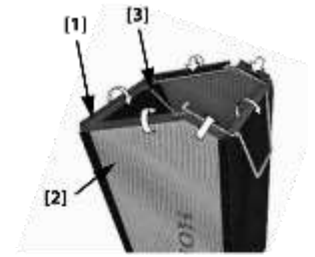

REPLACING A FUSE (HZE4)

The electric starter circuit and battery are protected by a 30 amp SLO-BLO fuse [1] and 3 amp fuse [2]. If the 30 amp fuse burns out, the electric starter will not operate and if the 3 amp fuse burns out, the battery will not charge. The engine can be started manually if either fuse burns out.

1. Remove the battery cover by removing the three cover mounting screws [3].
2. Remove and inspect the fuses. If they are burned out, replace with the correct fuse.

NOTICE

- The 3 Amp fuse is a "slow blow" fuse design. Do not replace with a standard fuse, or frequent fuse failure may occur.
- Never use a fuse with a rating other than shown. Serious damage to the electrical system or a fire can result.



If a frequent fuse failure occurs, it usually indicates a short circuit or an overload in the electrical system. Take the mower to an authorized Honda servicing dealer for repair.

OPERATION CHECK OF THE CUTTING-MEANS CONTROL

Start the engine outdoors. Release the cutting-means control lever; the engine should stop quickly. If the engine does not stop quickly, take the mower to an authorized Honda servicing dealer for repair.



Possible Cause	Correction
Fuel valve OFF	Turn the fuel valve ON (page 9).
Throttle lever in the wrong position (HYEA, HZEA types)	Move the throttle lever to the FAST position. (page 11).
Starter turns slow or not at all (HZEA type)	<ul style="list-style-type: none"> • Use the recoil starter for at least one mowing session to allow the battery to charge (page 8) • Check for blown fuse (page 17)
Out of fuel	Refuel (page 5).
Bad fuel; mower stored without treating the petrol, or refueled with bad petrol	Refuel with fresh petrol (page 5).
Spark plug faulty, fouled, or improperly gapped	Gap or replace the spark plug (page 14).
Spark plug wet with fuel (flooded engine)	Dry and reinstall the spark plug.
Fuel filter clogged, carburetor malfunction, ignition malfunction, valves stuck, etc.	Take the mower to an authorized Honda servicing dealer or refer to the shop manual for repair.

Possible Cause	Correction
Throttle not set to FAST (HYEA, HZEA, VYEA types)	Move the throttle to FAST (page 11).
Grass is too tall to cut	Raise the cutting height (page 6), cut a narrower swath, use a slower ground speed (page 11), or cut more frequently.
Cutting-means enclosure is clogged	Clean out the cutting-means enclosure (page 12).
Air cleaner is clogged	Clean or replace the air cleaner (page 14).
Bad fuel; mower stored without treating petrol, or refueled with bad petrol	Refuel with fresh petrol (page 5).
Fuel filter clogged, carburetor malfunction, ignition malfunction, valves stuck, etc.	Take the mower to an authorized Honda servicing dealer or refer to the shop manual for repair.

Possible Cause	Correction
Grass and debris lodged under the cutting-means enclosure	Clean out the cutting-means enclosure (page 12).
Cutting means loose, bent, damaged, or unbalanced by improper sharpening	<p>Tighten loose cutting-means bolts (page 16).</p> <p>If cutting means are found to be bent or damaged, take the lawnmower to an authorized Honda servicing dealer for inspection.</p>
Mechanical damage, such as a bent crankshaft	Take the mower to an authorized Honda servicing dealer or refer to the shop manual for repair.

MAINTENANCE SCHEDULE

Perform at every indicated month/year or operating hour interval, whichever comes first.

Item	Intervention	Frequency					
		Before each use	First month or 5 hours	First 25 hours	Every 6 months or 50 hours	Every year or 100 hours	Every 2 years or 150 hours
Engine oil	Check	o					
	Change		o		o ¹	o ¹	o ¹
Air filter	Check	o					
	Clean			o ¹	o ¹	o ¹	
	Replace						o
Spark plug	Check / Adjust					o	
	Replace						o
Spark arrester ³ (if equipped)	Clean					o	o
Fuel tank ²	Clean					o	o
Valve clearance ²	Adjust					o	o
Fuel lines ²	Check (replace if necessary)			Every 2 years			
Grass catcher	Check	o					
Cutting-means	Check	o					
Operation of the cutting-means control	Check	o				o	o
Rear shield	Check	o					
Cutting-means bolts	Check	o					
Select Drive cable (VKEA/VYEA)	Adjust		o	o	o	o	o
Cutting-means control cable (HYEA/HZEA) ²	Adjust			o		o	o
Drive clutch cable (HYEA/HZEA) ²	Adjust			o		o	o
Throttle cable (HYEA/HZEA/VYEA) ²	Adjust					o	o
Pinion gears ²	Grease					o	o
Idle speed (HYEA/HZEA/VYEA) ²	Adjust					o	o
Rear wheel adjuster bushing (HYEA/HZEA/VYEA) ²	Inspect-grease						o

1. Service more frequently when used in dusty areas.
2. These items should be serviced by an authorized Honda servicing dealer, unless you have the proper tools and are mechanically proficient. Refer to the Honda shop manual for service procedures.
3. In Europe and other countries where machinery directive 2006/42/EC is enforced, this cleaning should be done by your servicing dealer.

Failure to follow this maintenance schedule could result in non-warrantable failures or reduction in performance and emissions noncompliance.

TROUBLESHOOTING

ENGINE WILL NOT START

LOSS OF POWER

VIBRATION

MOWING AND GRASS CATCHING PROBLEMS

Possible Cause	Correction
Engine speed is too slow to cut well (HYEA, HZEA, VYEA types)	Move the throttle lever to the FAST position (page 11).
Lawnmower is moving too fast for lawn conditions	HYEA, HZEA, VYEA types Shift to a slower speed (page 11). VKEA type Move the Select Drive more toward MIN (page 11), engage the Select Drive lever less, or push slower.
Cutting height adjustment levers set at different positions	Set all levers at the same cutting height position (page 7).
Grass catcher overfilled or clogged	Empty the grass catcher. Wash the grass catcher if it is clogged with dirt (page 17).
Cutting-means enclosure is clogged	Clean out the cutting-means enclosure (page 12).
Cutting means dull, worn, or damaged	Sharpen or replace the cutting means if necessary (page 16).
Wrong cutting means installed	Install correct cutting means (page 16).

STORAGE

Proper storage is essential for keeping your lawnmower troublefree and looking good. The following steps will help protect the mower from rust and corrosion, and make the engine easier to start when you use the lawnmower again.



Cleaning

Clean the lawnmower, including the underside of the cutting-means enclosure.

Engine

Clean the engine by hand, using a rag and a brush.

NOTICE

Using a garden hose or pressure washing equipment can force water into the air cleaner. Water in the air cleaner will soak the filters and can enter the carburetor or engine cylinder, causing damage. Water contacting a hot engine can cause damage. If the engine has been running, allow it to cool for at least a half hour before cleaning.

Cutting-means Enclosure

To assure a longer lifetime and more efficient operation, the underside of the lawnmower must be kept clean and free of grass debris by cleaning with a brush and scraper. After use the lawnmower must be cleaned thoroughly before being stored.

Before cleaning the underside of the cutting-means enclosure, be sure the throttle lever is in the STOP position and the fuel valve is in the OFF position. Tilt the lawnmower to the right so the fuel cap is up. This will help to prevent fuel leakage and hard starting due to carburetor flooding. Wear heavy gloves to protect your hands from the cutting means.

Grass Catcher

Remove the catcher from the mower, and wash it with a garden hose or pressure washing equipment. Allow the catcher to dry completely before storage.

After the lawnmower is clean and dry, touch up any damaged paint, and coat other areas that may rust with a light film of oil.

Fuel

NOTICE

Depending on the region where you operate your equipment, fuel formulations may deteriorate and oxidize rapidly. Fuel deterioration and oxidation can occur in as little as 30 days and may cause damage to the carburetor and/or fuel system. Please check with your servicing dealer for local storage recommendations.

Petrol will oxidize and deteriorate in storage. Old petrol will cause hard starting, and it leaves gum deposits that clog the fuel system. If the petrol in your mower deteriorates during storage, you may need to have the carburetor and other fuel system components serviced or replaced.

The length of time that petrol can be left in your fuel tank and carburetor without causing functional problems will vary with such factors as blend, your storage temperatures, and whether the fuel tank is partially or completely filled. The air in a partially filled fuel tank promotes fuel deterioration. Very warm storage temperatures accelerate fuel deterioration. Fuel deterioration problems may occur within a few months, or even less if the petrol was not fresh when you filled the fuel tank.

Short Term Storage (30-90 days)

If your equipment will not be used for 30 to 90 days, we recommend the following to prevent fuel-related problems:

- Add fuel stabilizer following the manufacturer's instructions. When adding a fuel stabilizer, fill the fuel tank with fresh petrol. If only partially filled, air in the tank will promote fuel deterioration during storage. If you keep a container of petrol for refueling, be sure that it contains only fresh petrol. If it will take more than 3 months to use the fuel in your storage container, we suggest adding a fuel stabilizer to the fuel when you fill the container.
- After adding a fuel stabilizer, run the engine outdoors for 10 minutes to be sure that treated petrol has replaced the untreated petrol in the carburetor.
- Stop the engine and turn the fuel valve to the OFF position.
- Start the engine and continue to run the engine until it stops from the lack of fuel in the carburetor fuel bowl. Running time should be less than 3 minutes.

Note:

- All stabilizers have a shelf life and their performance will deteriorate over time.
- Fuel stabilizers will not reconstitute stale fuel.

Long Term or Seasonal Storage (greater than 90 days)

Start the engine and allow it to run long enough to empty all the petrol from the entire fuel system (including the fuel tank). Do not allow petrol to remain in your engine for more than 90 days of inactivity.

Fuel system damage or engine performance problems resulting from neglected storage preparation are not covered under the Warranty.

Engine Oil

Change the engine oil (page 14).

Engine Cylinder

If the mower is to be stored for more than 3 months, remove the spark plug (page 14). Pour 5 ~ 10 cm³ of clean engine oil into the cylinder [1]. Pull the starter rope several times to distribute the oil in the cylinder. Reinstall the spark plug.

Pull the starter rope slowly until resistance is felt, then return the starter grip gently. This will close the valves so moisture cannot enter the engine cylinder.



Placing in Storage

Since your mower will be stored with petrol in the fuel tank and carburetor, it is important to reduce the hazard of petrol vapor ignition. Select a well-ventilated storage area away from any appliance that operates with a flame, such as a furnace, water heater, or clothes dryer. Also avoid any area with a spark-producing electric motor, or where power tools are operated.

If possible, avoid storage areas with high humidity, because that promotes rust and corrosion.

Place the mower with its wheels on a level surface. Tilting can cause fuel or oil leakage.

The handlebar can be folded for compact storage (page 20).

With the engine and exhaust system cool, cover the mower to keep out dust. A hot engine and exhaust system can ignite or melt some materials. Do not use sheet plastic as a dust cover. A nonporous cover will trap moisture around the mower, promoting rust and corrosion.

Removing from Storage

Check your mower as described in *PREPARATION AND CHECKS BEFORE USE* (page 4).

If the cylinder was coated with oil during storage preparation, the engine will smoke briefly at startup. This is normal.

TRANSPORT

Before Loading

If the engine has been running, allow it to cool for at least 15 minutes before loading the mower on the transport vehicle. A hot engine and exhaust system can burn you and can ignite some materials.

Turn the fuel valve [1] to the OFF position. This will prevent carburetor flooding and reduce the possibility of fuel leakage.

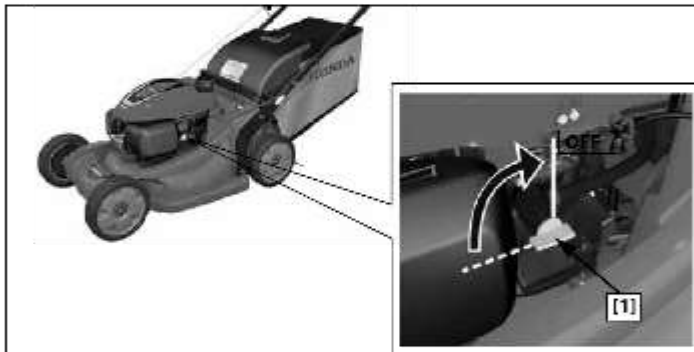

Handlebar Folding

1. Remove the grass catcher. You can place it on top of the engine, with the catcher opening to the front.

HVEA, HZEA types:

2. Turn the handlebar adjust knobs [1] 90° into the unlock position.
3. Fold handlebar [2] over the mower.

When folding the handlebar, be careful to avoid kinking or pinching the control cables.

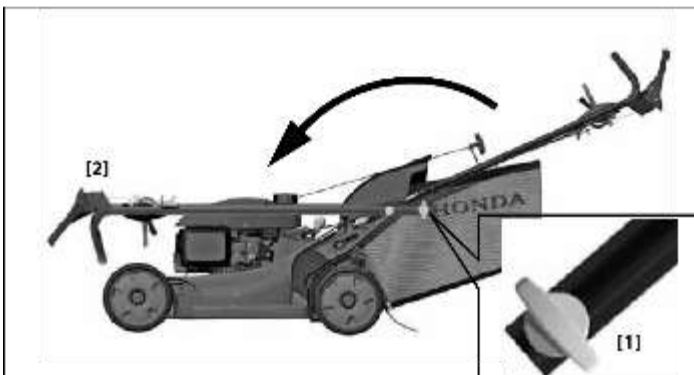

VKEA type:

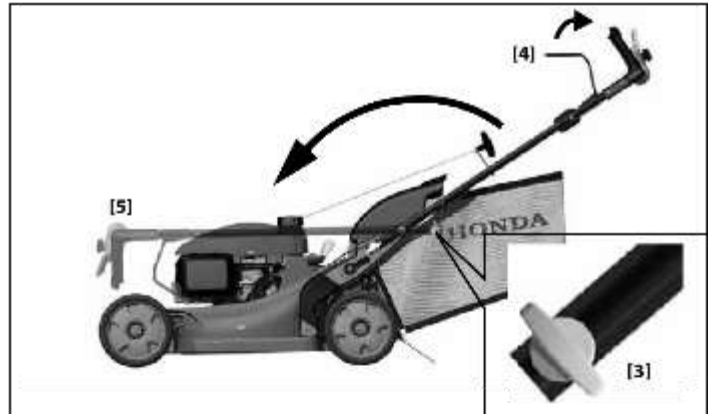

2. Unlock the handlebar adjust knobs [3].
3. Pull and hold the flywheel brake lever [4].
4. Swing the handlebar forward [5]. Prevent the cables from getting pinched or kinked. Ensure the cutting-means control lever clears the engine when folding the handlebar.

When unfolding the handlebar, be sure to lock the adjust knobs to secure the handlebar in the mowing position.

YVEA type:

2. Turn the handlebar adjust knobs [6] 90° into the unlock position.
3. Fold handlebar [7] over mower. Ensure the cutting-means control lever clears the engine when folding the handlebar.

When folding the handlebar, be careful to avoid kinking or pinching the control cables.

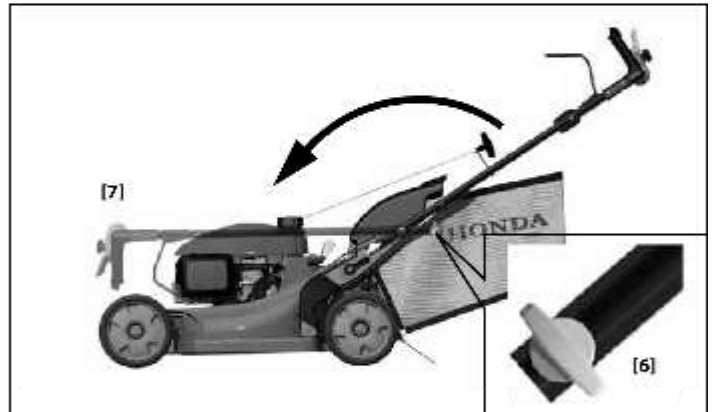

NOTICE

Do not allow the control cables to become caught, pinched, or kinked while folding the handlebar down into the storage position. The cables or engine control system may be damaged causing the lawnmower to not function properly.

Loading and Unloading

Position the mower so all four wheels are on the bed of the transport vehicle. Tie the mower down with rope or straps, and block the wheels. Keep the tie-down rope or straps away from the controls, adjustment levers, cables, and the carburetor.

NOTICE

To prevent losing control of or damaging the mower, do not use the drive system when going up or down a loading ramp.

To prevent damaging the drive system, do not engage the clutch when the mower is rolling backwards.

1. Turn the fuel valve to the OFF position.
2. Use a suitable loading ramp. Adjust the loading ramp so that it is inclined at an angle of less than 15° (26%). If a loading ramp is not available, two people should lift the mower on and off the transport vehicle while keeping the mower level.

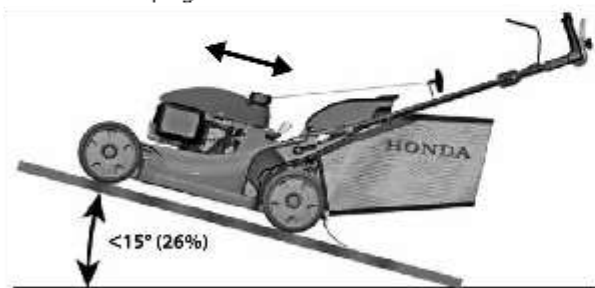

USEFUL INFORMATION

FIND AN AUTHORIZED DEALER

Please refer to page 23.

CURRENT PARTS, OPTIONAL ATTACHMENT AND CONSUMABLES

To buy one of the original parts listed below, or any other part, please contact an authorized Honda dealer.

Item	Part Number
Air Cleaner	17211-Z8B-901
Spark Plug	98079-55846
Cutting Means	72531-VH7-000 (upper) 72511-VH7-000 (lower)
Cutting-means Bolt (2)	90105-960-710 (HYEA, HZEA, VYEA) 90105-VA3-J01 (VKEA)
Bolt Washer (2)	90502-VG3-000
Wheel/tire	44710-VH7-010 (Front) (HYEA, VYEA) 44710-VH7-L50 (Front) (VKEA, HZEA) 42710-VH7-010 (Rear)

WARNING

For your safety, it is strictly prohibited to install any other attachment than the ones listed above and especially designed for your lawnmowers' model and type.



TECHNICAL SPECIFICATIONS

MODEL	HRX537C6			
TYPE	HYEA	HZEA	VKEA	VYEA
DESCRIPTION CODE	MCGF			
FUNCTION	Cutting of grass			

GENERAL				
Dimensions L x W x h	1 665 x 588 x 1 122 mm		1 610 x 588 x 1 073 mm	
Dry weight	44.2 kg	47.9 kg	40.4 kg	43.1 kg
Cut width	530 mm			
Cut height settings	19 mm, 32 mm, 46 mm, 62 mm, 75 mm, 88 mm, 101 mm			
Grass catcher capacity	76 l			
Sound pressure level at operator's ears (in accordance with EN ISO5395-2:2013 + A1:2016 + A2:2017)	84 db(A)	85 db(A)	84.4 db(A)	85 db(A)
Uncertainty	1 dB(A)			
Measured sound power level (in accordance with directives 2000/14/EC, 2005/88/EC)	96.23 dB(A)	96.55 dB(A)	96.41 dB(A)	96.15 dB(A)
Uncertainty	0.69 dB(A)	0.82 dB(A)	1.38 dB(A)	0.68 dB(A)
Sound power level guaranteed (in accordance with directives 2000/14/EC, 2005/88/EC)	98 dB(A)			
Vibration test (in accordance with EN ISO5395-2:2013 + A1:2016 + A2:2017) *	4.43 m/s ²	4.18 m/s ²	4.5 m/s ²	5.64 m/s ²
Uncertainty (EN12096)	0.48 m/s ²	0.48 m/s ²	1.2 m/s ²	0.74 m/s ²

ENGINE	
Model	GCV200A
Type	4-stroke, single cylinder, vertical shaft
Displacement	201 cc
Bore and stroke	66 x 59 mm
Cooling	Forced air
Lubrication	Splash and spray
Compression ratio	8.0:1
Maximum operating engine speed	2 850 ¹ / _{min} min ⁻¹
Idle speed	1 700 + 150 min ⁻¹
Net power **	4.2 kW
Nominal power	3.7 kW
Ignition system	Transistorized magneto
Spark plug	NGK: BPR5ES
Spark plug gap	0.7 ~ 0.8 mm
Air cleaner	Dry element type
Recommended fuel	Unleaded petrol E10
Fuel tank capacity	0.91 l
Recommended oil	SAE 5W-30, 10W-30, API SJ or later
Engine oil capacity	0.40 l *** Refill amount: 0.35 ~ 0.40 l
Carbon dioxide (CO ₂) emissions ****	Please refer to the CO ₂ values of the Honda engine at www.honda-engines-eu.com/co2

DRIVE

Type	Hydrostatic (HYEA, HZEA) Variable speed Select Drive (VKEA, VYEA)
Engine to transmission	V-belt
Main clutch	Fluid type (HYEA, HZEA) Slipping belt type (VKEA, VYEA)
Mower speed	0 – 1.61 m/s (HYEA, HZEA) 0 – 1.64 m/s (VKEA, VYEA)
Recommended fluid	Honda hydrostatic (HYEA, HZEA) SAE 10W-30, API SN or later (VKEA, VYEA)

* Values for a machine equipped with a grass catcher, in a grass collector position.

** The power rating of the engine indicated in this document is the net power output tested on a production engine for the engine model GCV200A and measured in accordance with SAE J1349 at 3 600 min⁻¹ (Net Power). Mass production engines may vary from this value. **Actual** power output for the engine installed in the final machine will vary depending on numerous factors, including the operating speed of the engine in application, environmental conditions, maintenance, and other variables.

*** Actual amount will vary due to residual oil in the engine. Always use the dipstick to confirm the actual level (see page 7).

**** This CO₂ measurement results from testing over a fixed test cycle under laboratory conditions of a(n) (parent) engine representative of the engine type (engine family) and shall not imply or express any guarantee of the performance of a particular engine.