

INSTRUCTION MANUAL

EN

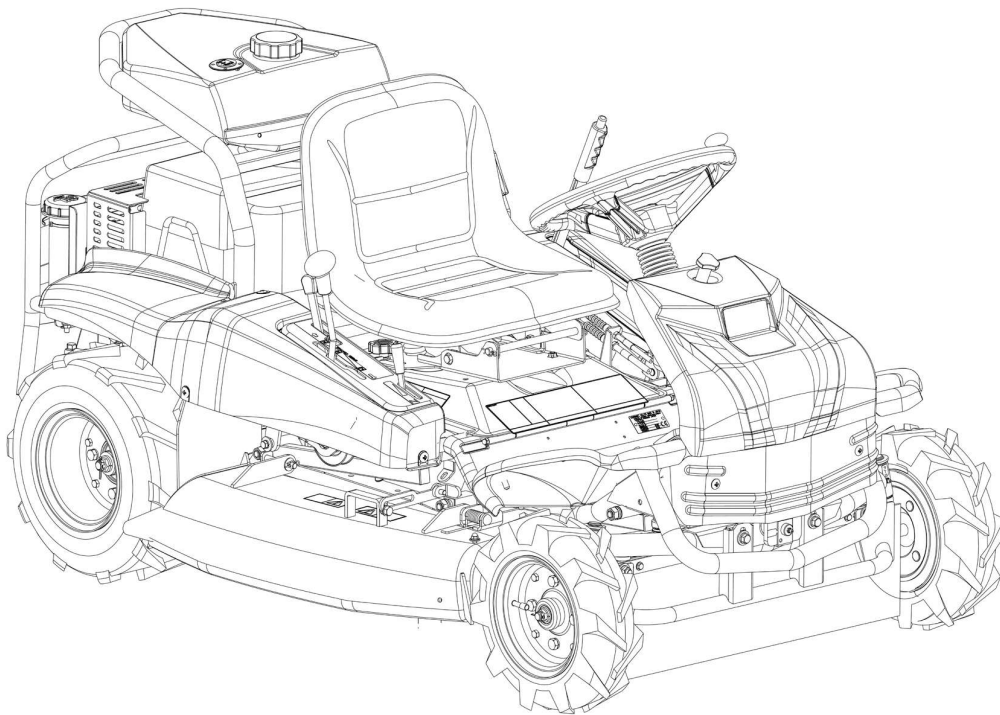

GRASSLAND MOWER RABBIT RM83G / RM830



Read this instruction manual carefully before any use of the machine, keep it as a reference. For any question about this manual, please report to your OREC dealer or to the distributor of your country.

OREC CO LTD

548-22 HIYOSHI HIROKAWA-MACHI YAME-GUN JAPON

<http://www.orec-jp.com>

UPDATE : November 2024

“only the English version of this manual can be used as a reference.”

INTRODUCTION

Forward to the user

Read this manual before any use of your mower, only the herein instructions shall help you to achieve an efficient and safe work.

A safe use will only result from the manner you will use the machine in accordance with the restrictions described in this manual. Thus, you must know and follow **all** the safety measures in this manual and those relating to the use of your tractor.

The MOWER that you have just bought has been designed and manufactured for your entire satisfaction. As any other mechanical machine, it requires a proper maintenance and must be kept clean. Grease the machine like indicated. Follow the rules and safety indications as described in this manual and as showed on the preventive instruction stickers.

About maintenance, always mind that your OREC dealer has the skills, the genuine parts and the necessary tools to solve the possible problems.

Use only the OREC original parts : “ non genuine ” parts will not assure you of a correct and safe working and are likely to make the guarantee null and void. Write the name and the serial number of your machine hereunder :

MODEL :

SERIAL NUMBER (refer to the pictures herein) :

Always mention these informations to your dealer in order to obtain the right parts.

Concerned about constant progress, OREC keeps the right to modify the machines without being compelled to modify those already sold.

The illustrations and characteristics in this manual might lightly differ from your machine because of the constant improvements made by our production department.

In this manual, the left and the right hand or the rear and the front position are determined according to the tractor seat.

All along this manual the word **IMPORTANT** is used to indicate that a fault might cause damage to the machine. The words **WARNING**, **CAUTION** and **DANGER** are used with the “ safety/warning ” pictogram (triangle with an exclamation mark) in order to indicate a hazard for your safety.

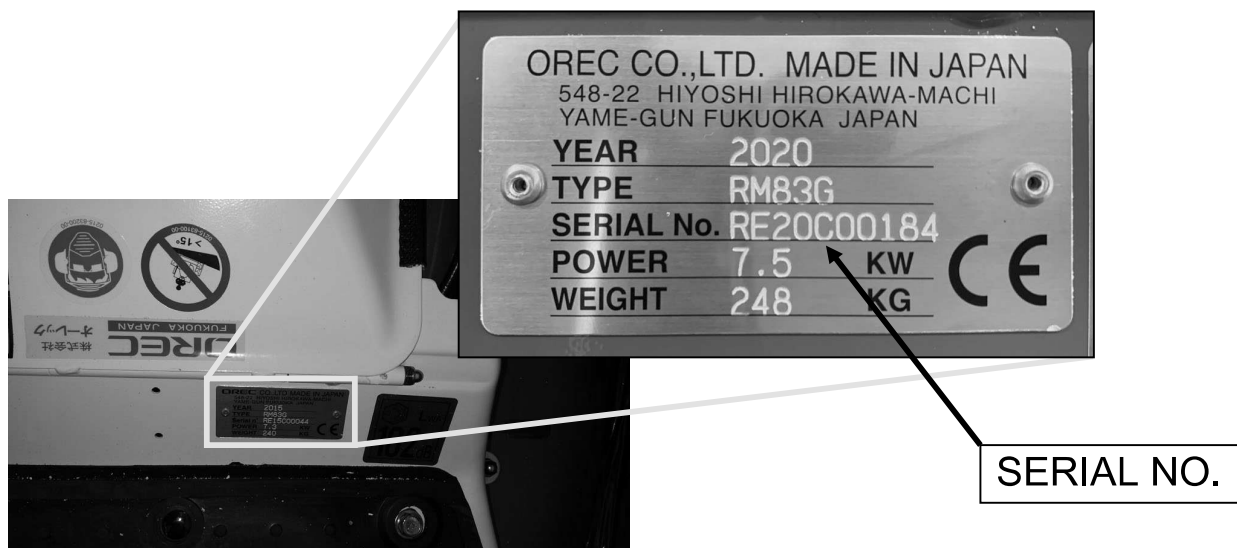



This symbol indicates that you must be very attentive because your safety is at stake. It reminds that you must follow the safety instructions and pay attention to hazardous operations that might cause injuries.

 **WARNING**

Reminds the safety rules that might cause injury if they are not respected

 **CAUTION**

Remembers to pay attention to a real danger that is likely to cause injury or even death if no proper precaution is taken.

 **DANGER**

Indicates a major hazard that is most likely to cause irremediable injury or death if the right precautions are not taken.

CONTENTS

INTRODUCTION	1
SPECIFICATIONS	2
CHECK LIST	3
SAFETY RULES	3
MACHINE DESCRIPTION	5
SAFETY INSTRUCTION STICKERS	6
CONTROLS	8
OPERATION	12
MAINTENANCE OPERATIONS TO BE CARRIED OUT BY THE USER	14
BREAKDOWNS AND SOLUTIONS	21
TIGHTENING TORQUES (Nm)	21
LIMITED WARRANTY	22
NOTES	22
EC CONFORMITY DECLARATION	23
MEASUREMENT OF VIBRATIONS	23

SPECIFICATIONS

Model	RM83G	RM830
Engine	HONDA GXV 390	HONDA GXV390
Transmission	Mechanical	Hydrostatic
Forward speed (km/h)	4 positions 1.9/3.1/5.1/7.9	0 - 10
Reverse speed (km/h)	2.2	0 - 4.5
Cutting width (mm)	820	820
Height of cut (mm)	50 - 110	50 – 110
Weight (kg)	248	240
Fuel Tank (liters)	11	11
Blade transmission	Belt	Belt
Steering	Gears	Gears
Blade engagement	Belt tension	Belt tensio
Blade speed (rpm)	1300	1353
Width (mm)	990	990

CHECK LIST

INSTRUCTIONS TO THE DEALER

The assembling, the installation and the first application of the machine is under the OREC dealer's responsibility.

Read the instruction manual as well as the safety measures. Check that all the before delivery and at delivery check points specified in the following lists have been verified and possibly modified before delivering the machine to its owner.

CHECKS BEFORE DELIVERY

- Check that all the shields, grids and safety guards are in place and in a good state.
- Check that the hydraulic hoses are in place and in a good state. Replace them if necessary.
- Check that there is no oil leak, repair if necessary.
- Check that the safety instruction stickers are in place and in a good state. Replace them if necessary.
- Check that all the bolts and screws are properly tightened with the right torque (refer to chart).
- Protect the grease nipples by coating them with grease and lubricate the machine.
- Check that the machine can work properly.

CHECKS ON DELIVERY

- Show the user how to perform the adjustments.
- Explain to the user the importance of the lubrication and show him the different greasing points on the machine.
- Show him the safety devices, grids, guards and the optional equipments.
- Give the instruction manual to the customer, ask him to read it carefully.
- Explain to the customer that drive on the public roads is forbidden.

SAFETY RULES



CAUTION

Some of the illustrations show the machine with no guard, no shield. Never use the machine without these devices.



CAUTION

Never go on public roads with the machine. The mower is not allowed to go on public roads. Always use a truck or a trailer to go from a mowing area to another.

- Learn to stop the machine in case emergency.
- Read this manual.
- Do not let anybody use the machine before having read and understood this manual.
- Do not let children use the machine.

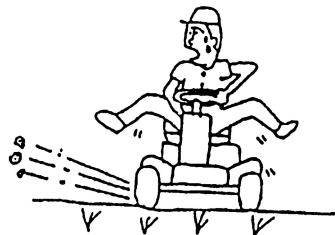

- Do not wear loose clothes. They might be grasped by moving parts.
- Always wear protection equipments for when using the machine.
- Only work during daylight or with a good artificial light.
- Check that the safety instruction stickers are in place and in a good state.
- Keep the machine free from debris or mud.



- Check that the machine can work properly before any use.
- Check that all the shields, grids and safety guards are in place and in a good state.
- It is strictly forbidden to carry persons or animals onto the machine during the work or during the transportation.
- Check that nobody stands behind the machine before moving back.

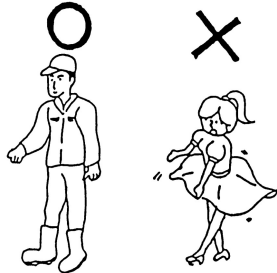
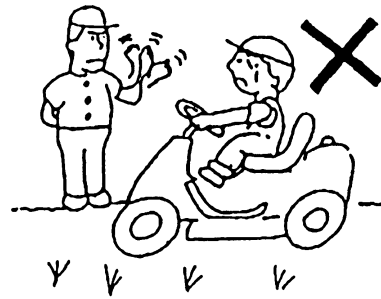

- Never stop or start roughly when working on a slope. Never use the machine to work on a stepping terrain.
 - Reduce the ground speed when running on a slope and when turning straight in order to prevent from any risk of losing control.
 - Be very careful when bordering ditches.
 - Stop the engine, put on the handbrake and remove the ignition key before any intervention on the machine.
 - Never work under the machine or its parts when lifted, unless they are blocked and maintained into position with sufficient security.
- When running on a slope, always work going up or down but never across the slope.

- Steer clear of unsteady embankments, holes or rocks. They might be dangerous during maneuvers or transport.

- Be careful when working on slopes.
- Keep away from high-tension lines and obstacles. A contact with a high-tension line cause electrocution and death.
- Stop the machine progressively when lifting or lowering the machine.
- When stopping the work, stop the engine and put on the handbrake before leaving the mower.
- Check that the perform rests on its stands on a flat and hard soil when it is uncoupled.

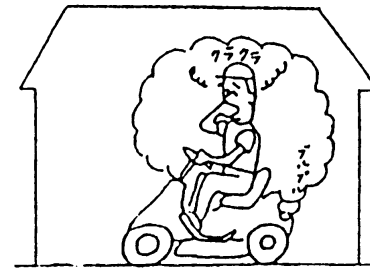

- Engage all the safety equipments.
- Move the controls only when correctly sat down in the mower
- Visually check hydraulic leaks and if some parts are faulty or missing. Repair before use.
- A hydraulic oil jet due to a leak can penetrate under the skin causing serious injuries. In this case you must immediately consult a doctor.
- Never change the adjustment of the safety valve, it is set in the factory. Unsetting this valve would cause failures.

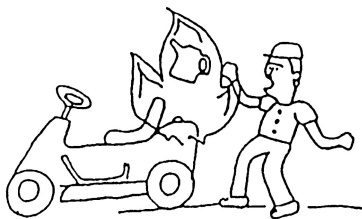

- Ensure that the user of the machine has already read and understood this manual and that he is aware of all the safety instructions before any use.

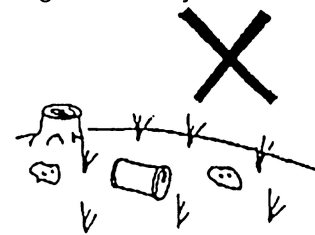

- Always use a chuck and bronze hammer when replacing or intervening on the pins and bolts at the end of rams, rod ... etc in order to avoid the projection of metal fragments.

MACHINE DESCRIPTION

<<RM83G / RM830>>

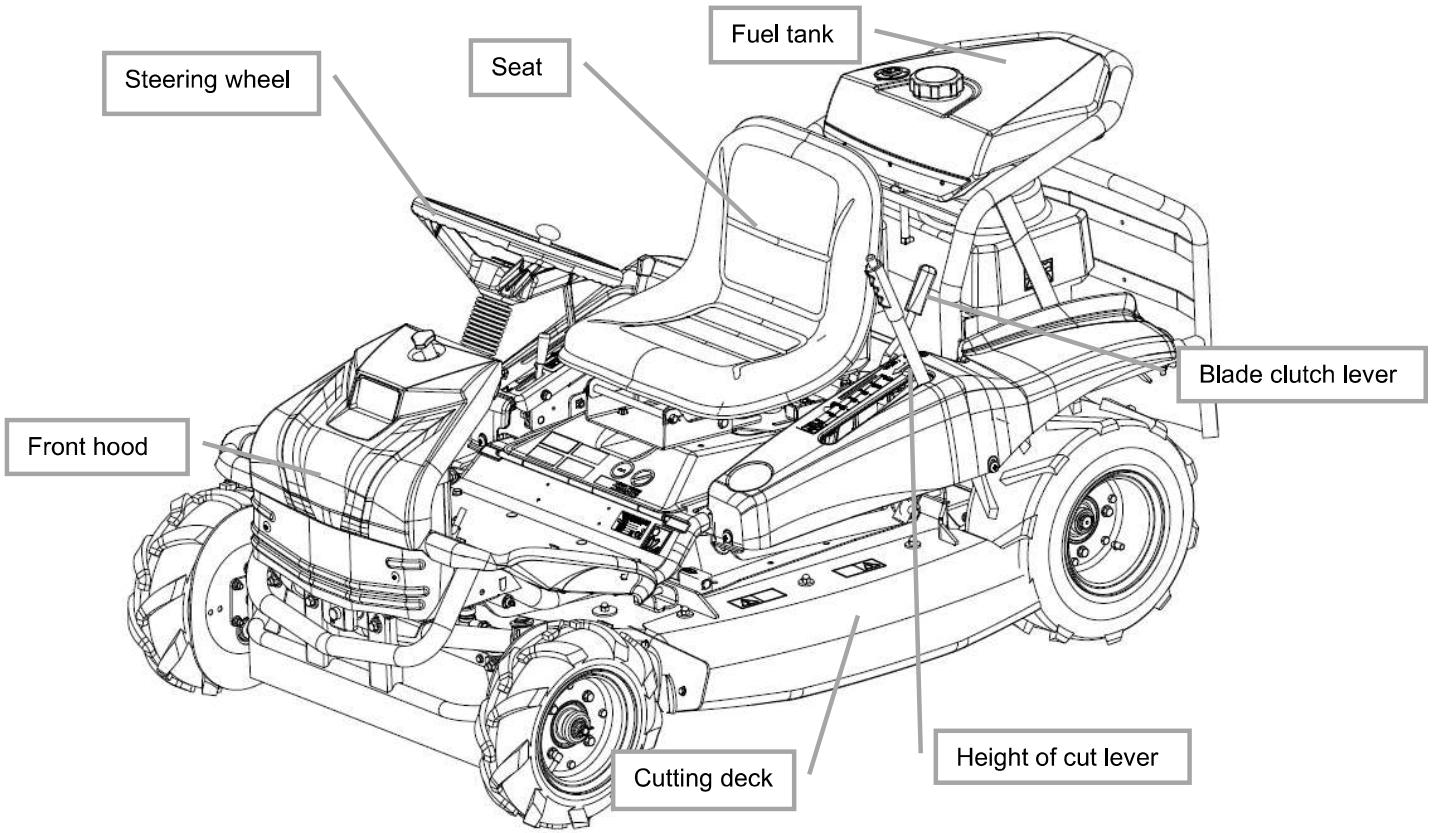

Figure1

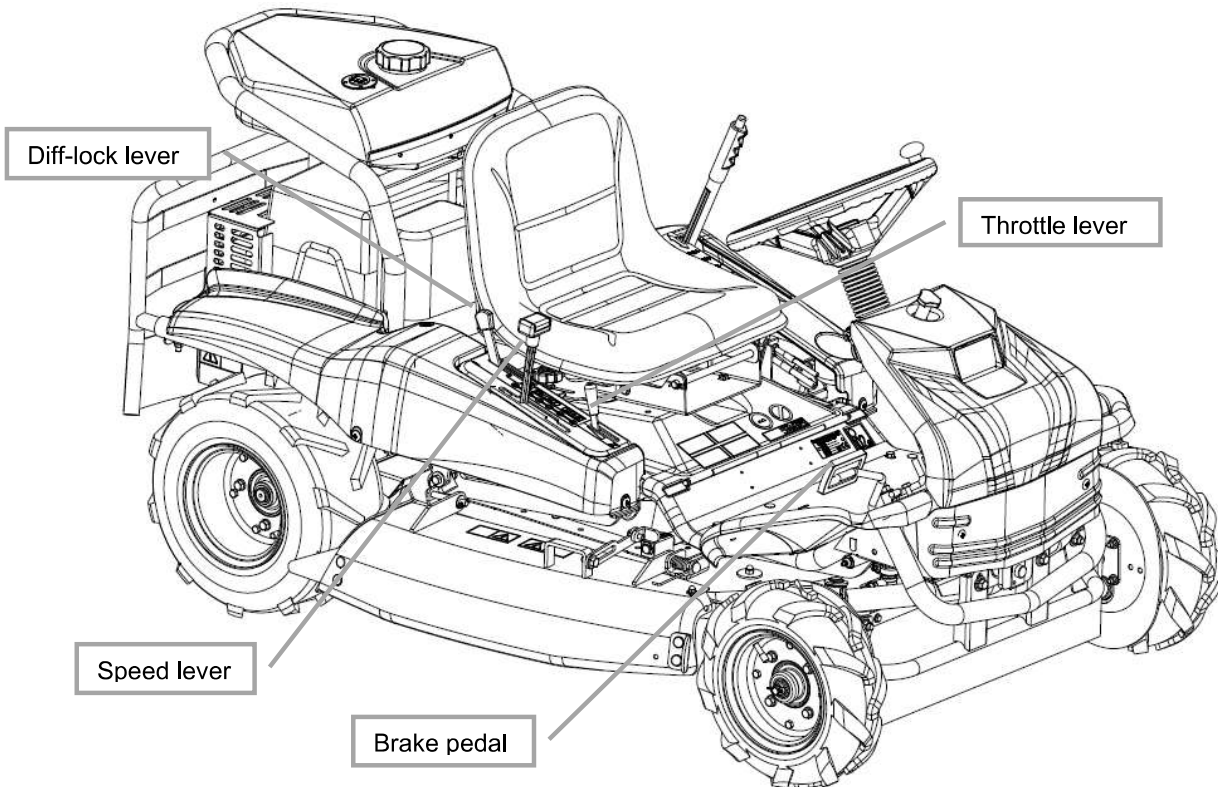

Figure2

SAFETY INSTRUCTION STICKERS

Note their place and replace them immediately in case of damage or when missing



Do not exceed 15° slope

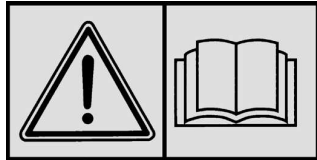

Read owner's manual

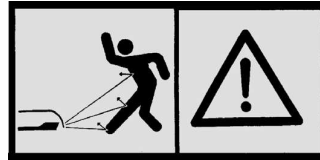

Beware of thrown objects



Remove the spark plug wire before maintenance

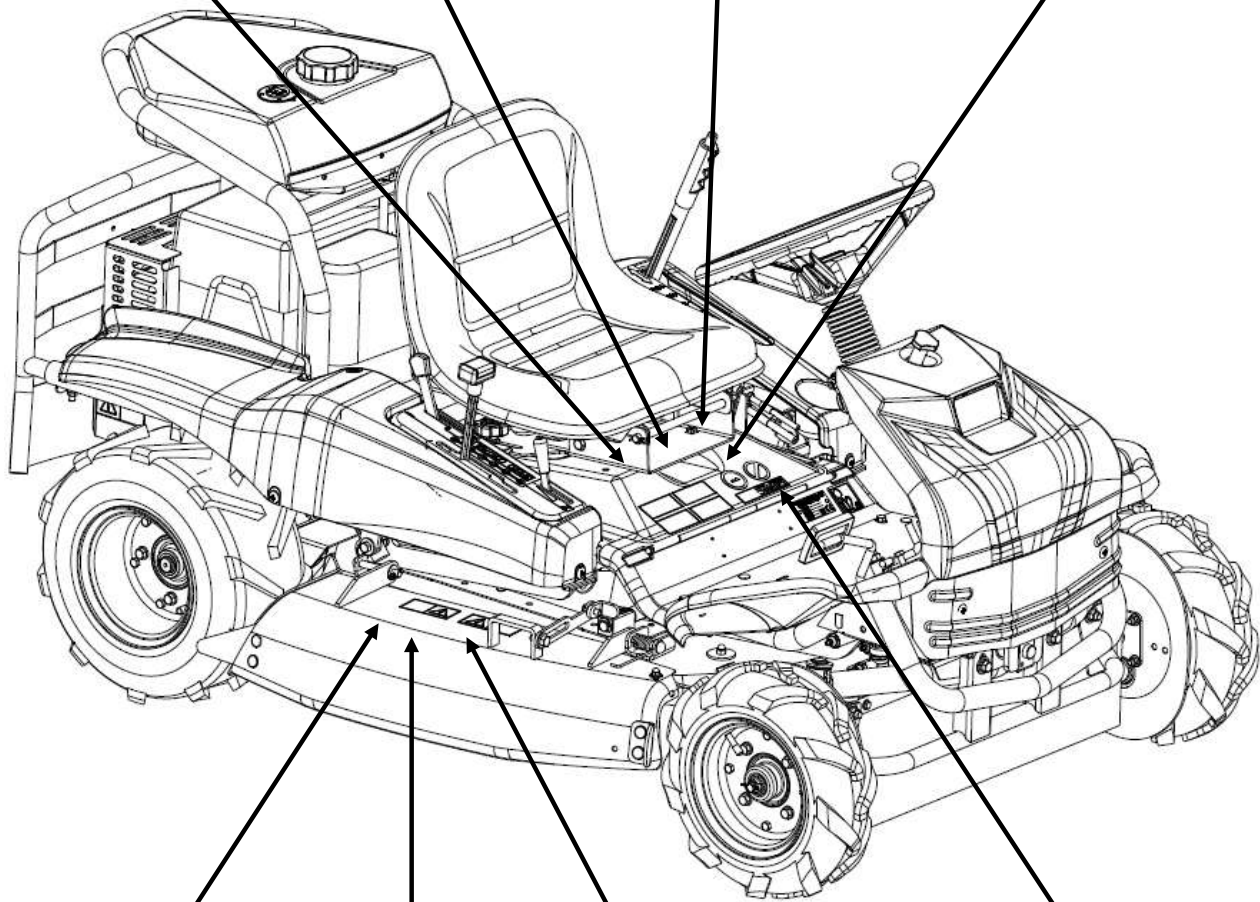

Figure 3



Beware of rotating parts under the shields



Keep hands and feet away from rotating blades

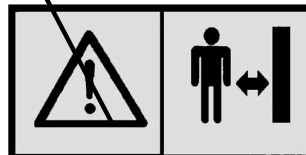

Stay away from the machine



Always wear protective equipment against noise, dust



Beware of hot surfaces near engine

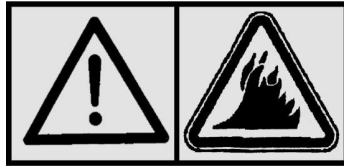

Beware of the flammable fuel



Beware of the toxic exhaust gases

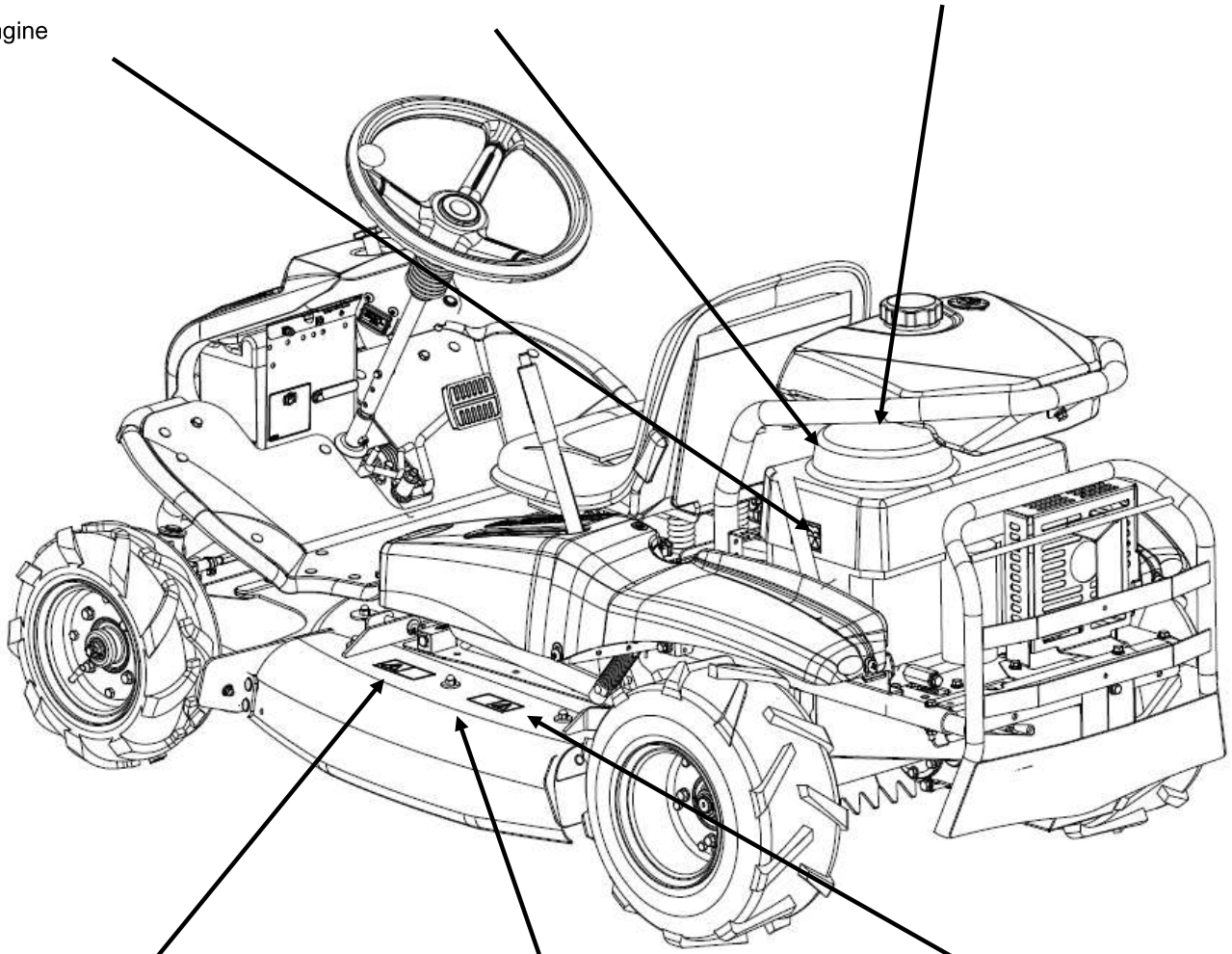

Figure 4



Beware of rotating parts under the shields



Keep away from the machine



Keep away hands and feet from rotating blades

CONTROLS

« RM83G »

« RM830 »

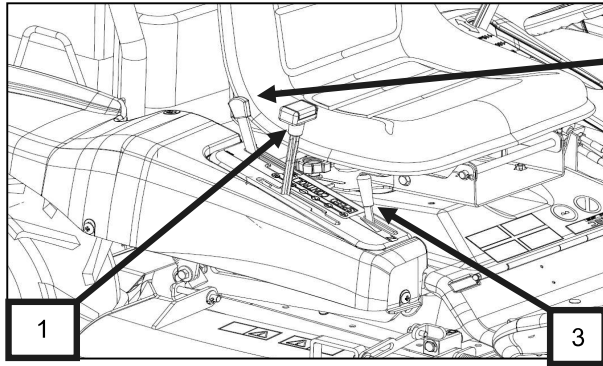

Figure 5a

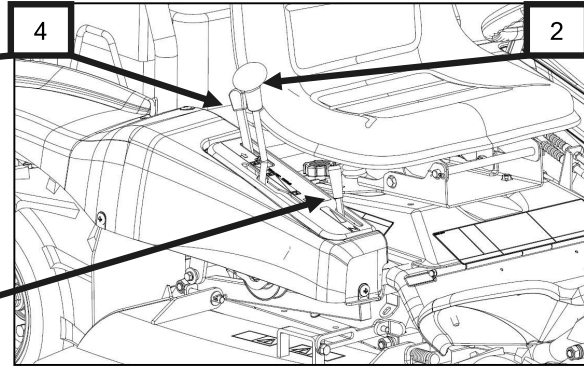

Figure 5b

SPEED CONTROL LEVER (4 SPEED GEAR) <<RM83G>>

This lever (1, Fig 5a) is used for running of this unit, stop operation, running direction and speed adjustment.

Shifting is R "reverse" , N "neutral" , "Advance" has four stages of speed of 1, 2, 3, and 4. The speed changes in the order of "low speed" 1 → 2 → 3 → 4 "high speed". 4th gear is for only moving, so please DO NOT use it for mowing work. The speed is too fast and unsuitable to work. Switch to forward / reverse after the machine has completely stopped.

If you switch it while driving, the transmission mechanism will be damaged.

SPEED CONTROL LEVER (HST) <<RM830>>

This lever (2, Fig 5b) is used to go forward, reverses and stop the machine. When the lever is placed rear to « R » the machine is going on reverse. When lever is placed in front of « N » to « F » the machine is going forward. When lever is placed in « N » position the machine is stopped.

Travel speed is increased by push the lever from « N » to « F » or « R ». Travel speed is decreased by push the lever from « F » or « R » to « N ».

Push or release lever gradually (except on an emergency) to avoid sudden stop and go.

THROTTLE LEVER

Push the throttle lever (3, Fig 5a,b) forward to increase engine speed, pull the throttle lever rearward to decrease engine speed to idle rpm. Always operate mower at full engine speed.

CHOKE

Push the throttle lever completely to the front to activate the choke to start cold engine, and release it gradually when engine become hot.

DIFFERENTIAL LOCKING LEVER

This lever(4, Figure 5a,b) allows the rear wheels to be driven together in slipping areas. Apply the diff lock lever when one wheel is slipping in straight line. Release the lever as soon as the machine leaves the slipping area.



The diff lock should be used in straight line only : never use the diff lock lever when turning. The damage to the transmission will not be covered by the warranty

BRAKE PEDAL & LOCKING LEVER

Brake pedal is used in case of emergency or when parking brake is locked (1,2, Figure 6).

To lock parking brake, press brake pedal, then push locking lever (2) to the right. Depress the pedal, and after, the lever. To unlock parking brake, press and depress brake pedal.]

(RM83G only)

Press the brake pedal (1, Figure 6) each time to change the speed. When the brake pedal is pressed, brake works to stop machine.

For your safety, always press the brake pedal first, then change the speed lever position after the machine is stopped.

(RM830 only)

In the normal operation, use speed lever to stop the machine at N position.

In case of emergency, press the brake pedal (1, Figure 6) to stop machine, then speed lever returns to N position.

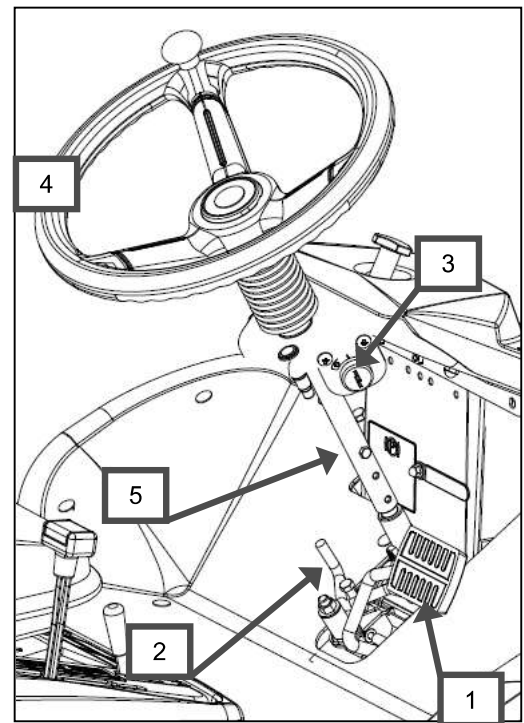

Figure 6

⚠ WARNING

Always inspect the brake before each use. If the brake is not properly adjusted, it may lead to serious accident such as collision or fall. Press the brake pedal, then brake works to stop machine. When the brake pedal is pressed, it is possible to use locking lever (2, Figure 6) to lock the parking brake. When brake pedal is further pressed, parking brake is unlocked. Engine cannot be started when brake pedal is not pressed(locked).

⚠ WARNING

When leaving the machine be sure parking brake is locked, cutting blades are in off position and ignition key is removed.

IGNITION KEY

Ignition key (3, Figure 6) is used to start and stop the engine.

- When the key is in "**stop**", position the engine is stopped, the key can be removed. Turn the key in this position when you want to stop the engine.
- When the key is in "**operation**", position the engine can run, the key cannot be removed in this position
- When the key is in "**start**", position the electric starting motor is engaged. When the engine has started, release the key wich return in "**operation**", position.

STEERING WHEEL

The steering wheel(4, Figure 6) is used to allow the direction of the machine. Turn the steering wheel to the right (clock wise) to go right and to the left to go to the left (anti-clockwise) Adjust the steering wheel height (3 positions) by removing the pin (5, Figure 6). Adjust the steering wheel, and secure the pin (5, Figure 6).

⚠ CAUTION

Always remove the key when machine is not used. When the engine is stopped, check than the key is on "stop" position. Do not engage the electric starting motor more than 10 seconds. If the engine has not start after 10 seconds, wait for 30 seconds before engage the electric starting motor again.

⚠ WARNING

Use brake pedal in case of emergency only or to lock parking brake. If brake pedal is used at high speed, the machine will stop suddenly.

⚠ WARNING

Do not let park the machine in slopes, do not move the travel lever when parking brake is locked, this will damage the transmission. When leaving the machine be sure parking brake is locked, cutting blades are in off position and ignition key is removed.

HEIGHT OF CUT CONTROL LEVER

The highest position of the lever (1, Figure 7) match to the transport position. You can adjust the cutting height freely by pressing the push button (2) and the lever (1). When the lever position is high, the height of cut is high, when lever position is low, the height of cut is low.

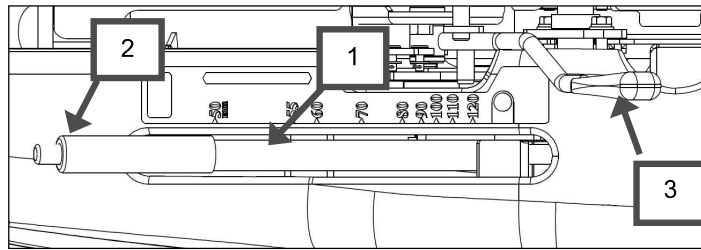

Figure 7

⚠ WARNING

When cutting height is in low position, the machine needs stronger power, and spread more thrown objects. Cutting low can cause damage to the machine and injury.

BLADE CLUTCH LEVER

Blade Clutch lever (3, Figure 7) make the engine drive the blade to mow. Pushing the lever forward make the blade turning. Pulling the lever on reverse to stop the blade. When using blade clutch lever, check that height of cut lever is in mowing position.

MOWING DECK SIDE SHIELDS

The mowing deck side shields should be unlock only to allow the machine to be loaded on a truck or a trailer. This shields should be locked for mowing.

⚠ DANGER

The mowing deck side shields should be locked by bolt and nuts when mowing with the machine. Check if guards and shield are locked by bolt and nuts before mowing with the machine. If they are not locked, thrown object will cause injury and damage.

ENGINE

The mower is delivered with the owner's manual of the engine. Read the engine manual before using the machine.

DRIVING CLUTCH LEVER (RM830 ONLY)

This lever (1, Fig 8) is used when the operator needs to move the machine without the engine. The lever is located at the right front side of operator sheet. Put down the lever then move to neutral position « N » (Figure 8). When machine pushed, the brake pedal must be released.

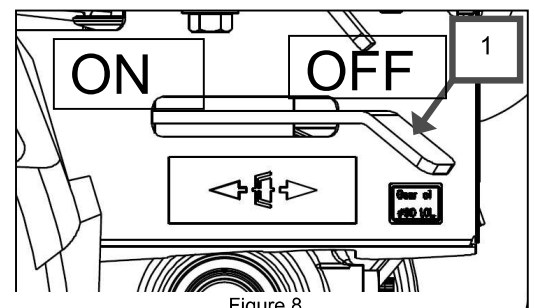

Figure 8

SAFETY SWITCHES

The OREC mower is equipped with safety switches :

- To start the engine, followin 3 points need to be satisfied
 - An operator is seated
 - Height of cut lever is in transport position.
 - Blade clutch lever is disengaged.
- When the engine is running, the operator leave the seat, the engine is cut off.

 **WARNING**

**Never start the engine when operator is not seated in his place.
Do not dismount, cut off, unplug or shunt the safety switches.
If the engine is cut off by a safety switch put the ignition key in
"stop" position to avoid unloading of the battery**

FUEL COCK

The machine is equipped with a fuel cock. This one is closed when the lever is to the right and open when it is pushed to the left. (Figure 9, 1).



Figure 9

OPERATION



CAUTION

Check the tightening of bolts before use the machine, referring to the tightening torque charts.

The safety is one of our main worry when designing and manufacturing this machine. Therefore, negligence in the use of the machine should reduce our efforts to nothing. The prevention strictly depends on the care and on the skill of the user when applying and maintaining the machine. The best safety method remains a careful and skilled user ; we wish you to be this kind of user.

The user of this machine is responsible for its safe use. He must be a skilled user specially trained for the use of this machine. Read the safety instructions. This machine has been designed to mow grass. It is not designed for any other operation. It is no designed to transport other tools or materials that might damage it and cause injuries to the user. It must not be used to carry persons.





Never use the machine without having priorly carried out all the maintenance operations as described in the daily maintenance chapter.



CAUTION

Never let children or unskilled persons use the machine. Check that nobody or no object stands near the machine when at work. They could be hit by the moving parts. Nobody must stand on the machine except the driver. Never put your hands under moving parts.

STARTING OF THE ENGINE

- Turn the fuel cock "ON" and seat down at operator's place.
- Check that the cutting blade is disengaged, height of cut lever in transport position and speed lever in neutral position « N ».
- Push the throttle lever to the [] if engine is cold or push the throttle lever to [] if engine is hot. Press the brake pedal and turn the key clockwise in start position. When the engine has started, release the key and pull back the throttle lever to []

MOWING

1. Adjust the height of cut control lever as needed.



WARNING

Do not forget that it is better to mow grass in several times. Cutting result is clear and efficient. Remember that the machine is deteriorated rapidly in hot and dry weather. When the cutting height is low, the blade may hit the ground and it causes damage to the blade. The user and bystanders are likely to be injured by the thrown object, The thrown object cause damage to their properties.

2. Push the throttle lever to have the engine running in the fastest speed. Then, slowly engage the blade clutch lever in mowing position and go forward in the grass to mow.
3. Push slowly cutting blade control lever in engage position and go forward in the grass to mow.

⚠ WARNING

Engage the blade with engine at full speed gradually to avoid damage to the belt.

The best cutting speed depends of quantity and the density of the grass. Usually it is asked to mow in low speed. A tall grass will be cut slowly and a low grass will be cut faster. It is very dangerous to work on a slope. Never work in slopes more than 15°.

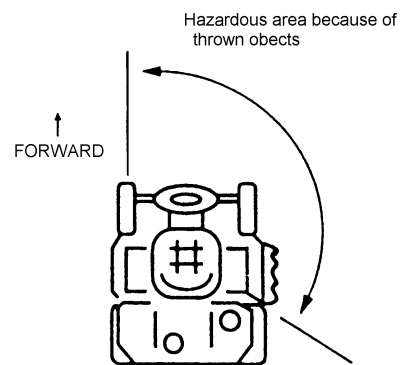

Figure 10

⚠ WARNING

Check if there is nobody in the mowing path and especially in the thrown object zone (Figure 10). Stop the machine immediatly when hitting something. Let the machine get cold, clean the machine from dust and debris. Check the machine or ask your dealer to check if the machine is not damage.

HOW TO STOP THE MACHINE

- Pull cutting blade clutch lever to the top in disengage position, pull height of cut lever to the top on travel position.
- (RM830) Hold down the lever to neutral position « N »
- Press the brake pedal to stop the machine..
- Turn off ignition key to stop position and remove it.
- Lock the parking brake, and close fuel cock.

⚠ WARNING

Avoid parking the machine in slopes, park the machine in a flat hard area.

HOW TO CARRY THE MACHINE

Use a trailer or a truck which is enough for the load of the machine. When loading the machine, use ramps able to resist to 500 kg, 30 cm wide and equipped with unslipping surface. Check the slope is not more than 16° (Figure 11).

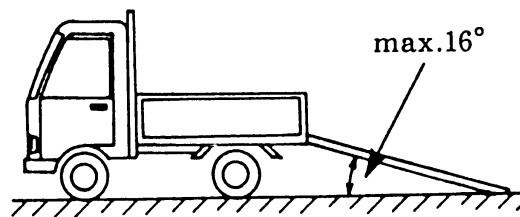

Figure 11

LOADING :

- Check cutting deck is disengaged and in travel position. Lock the differential locking.
- Approach the machine of the parralel ramp adjusted to the track and locked to the truck.
- Load the machine with engine at full rpm, slowly and with care.
- When the machine is loaded, Turn off ignition key to stop position and remove it. Lock the parking brake, and close fuel cock. Trim the machine with straps designed according to the weight of the machine.

STORING THE MACHINE

- Thoroughly clean the machine. Use touch up paint to prevent rust.
- Check for worn and damaged parts, install new parts as required
- Preform the normal maintenance of the machine according to maintenance chart.
- Store the machine in a dry protected area
- Remove ignition key.

MAINTENANCE OPERATIONS TO BE CARRIED OUT BY THE USER



IMPORTANT

BEFORE perform any maintenance operation on the machine, cut off the engine, disengage the cutting blade. Lock the park brake and remove the ignition key. Do not let anybody approach the driving place

If maintenance operation is not realized, damages can occur to the machine and personal injuries to the user and/or spectators. These damages and injuries will not be covered by the warranty.

- Daily maintenance will be performed by the user.
- Maintenance operations for first 20 hours, 100 hours and 300 hours should be realized by the dealer.
- Ask your dealer to check the machine if you meet some problems.
- Ask your distributor the name of your dealer.

Daily maintenance

Transmission (gear) oil level (Figure 12a, b)

Check level with the machine cold on a flat surface. Oil level should reach the middle of the window (A). If needed, add oil by this window. Drain oil by « B » plug.

Transmission Oil: "SAE 90" or "API GI-5"

Quantity: **1.60L (RM83G)** , **1.00L (RM830)**

Transmission oil replacement frequency

First replacement: After 20 hours of operation	Later replacement: Each 100 hours or Every year, whichever comes first.
---	--

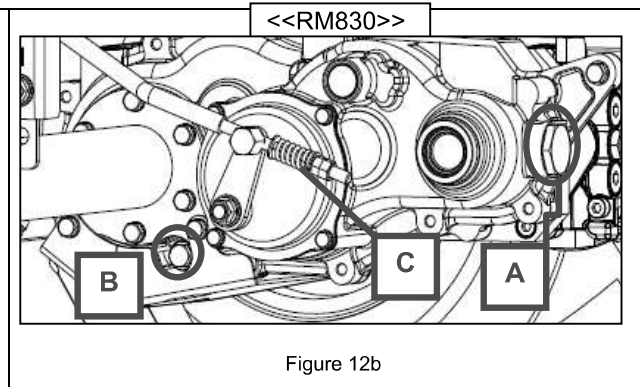
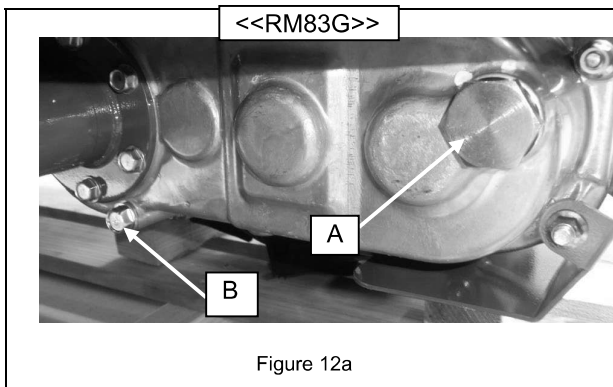

HST oil level (Figure 13) (RM830 ONLY)

Check level with the machine cold on a flat surface. Oil level should reach the upper level "UP". If needed, add "VG46" or "SAE 10W30".

Oil capacity: 0.50L

Check for oil leak.

Do not exceed upper level.

HST oil replacement (RM830 ONLY)

HST oil is clean when the unit is delivered. But when the unit is used for a long time, the inside of HST unit will be dirty because there are some sludges, and the oil is degraded. And dirty oil might disturb the smooth working.

Replace HST oil frequently for your safety and smooth working.

Also replace oil filter when HST oil is replaced.

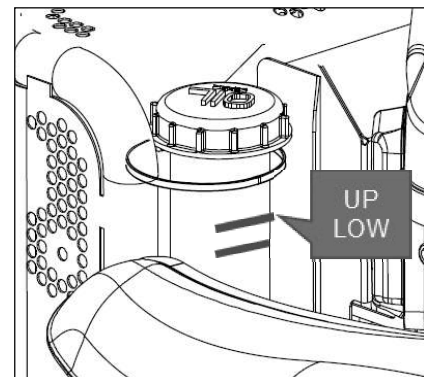

Figure 13

Drain the used HST oil (RM830 ONLY)

1. Place the suitable container below the HST unit to catch the oil, then remove the oil drain plug (A Figure 14).
2. Allow the used oil to drain completely, then reinstall the oil drain plug, and tighten the oil drain plug securely.
3. With the HST unit on a flat surface, refill to the upper limit mark with the recommended oil. **(Refill same oil if possible.)**
When oil is added, please pay high attention not to mix dust with oil. Tighten the cap securely to prevent leakage.



Never loose the bolt (B Figure 14). Otherwise, it might influence for machine driving. To do so is considered misuse, and damage caused by misuse is not covered by Warranty.

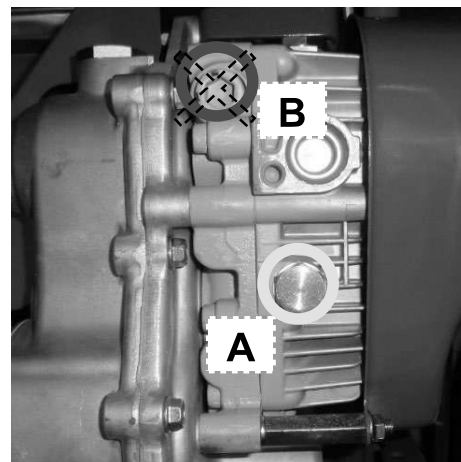

Figure 14

Breeding the hydrostatic transmission system : (RM830 ONLY)

- After replacing the HST oil, some air can go in the hydrostatic system. If there is air in the transmission system, the driving is not perfect. Please do as following.
- **Tilt the change lever by half to FORWARD and BACKWARD for 10 seconds and then, return the change lever to neutral position. (Figure 15)**
***Please do above 2 works 5 times.**
When tilt the change lever, throttle must be kept idling.
- And then, please make sure if there is no bubbles in the HST oil tank.
- After working, please make sure if the oil level reaches "High level position" in oil tank.
If not, please add oil up to "High level position" in oil tank. (figure 18)

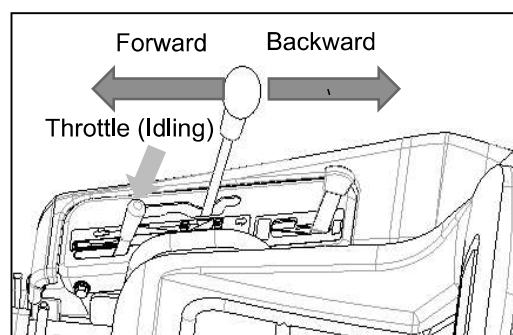

Figure 15

HST oil replacement frequency

First replacement: After 20 hours of operation	Later replacement: Each 200 hours or Every year whichever comes first.
---	---

References: (The color of HST oil)

Color	Smell	Status	To do
Clean and no changing color.	Good	No foreign object	Use as usual
Clean, but there are some black points.	Good	Some foreign object	Use after filtering
Milky white	Good	Some water.	Change the oil
Black	Bad	Oxidated and degrade.	Change the oil

Fuel (Figure 16 and Figure 17)

- Check that the fuel tank level is full(1, Figure 1). Fuel level is full when the needle of the gauge indicated « F ». Fuel level is empty when needle of gauge indicate « E ». If fuel is empty, need to load the fuel. Check that tank cap is fully closed, and check for leaks. Use only a good quality gasoline(11.00L).



Figure 16

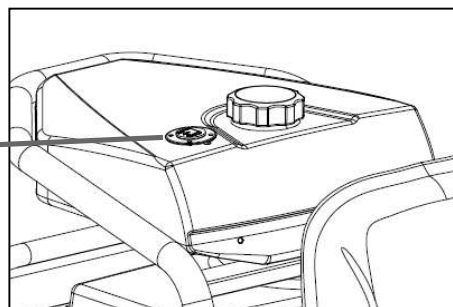

Figure 17

⚠ DANGER

Check that the fuel tank cap is closed properly, wipe leaky fuel before to start the machine.
Check there is no fire, electric sparks, cigarettes near the machine when refuelling.
When the machine is used on slopes, work with the fuel tank half full to avoid fuel leaking.

Remove flammable materials :

Remove flammable materials espacially near hot parts such as mufflers or engines.
It might cause fire.

Tires (Figure18)

- Check the tires are not cutted, cracked or worn.
- Check the pressure of the tires : 1,2 bar front and 1,4 bar rear.

Safety stickers

Check the safety stickers are sticked at their location. Replace them if they are worn and damage.

Latelal guards and shields

Check that the lateral guards and the shields are bolted.

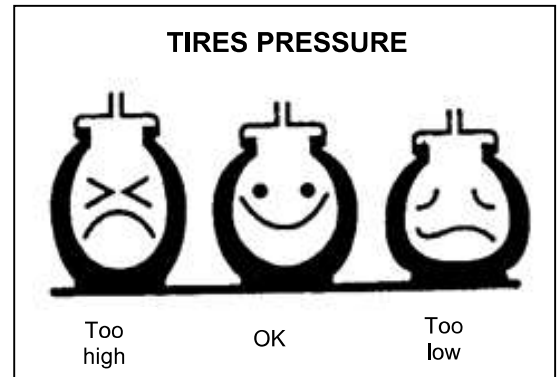

Figure 18

Electrolyte battery level (Figure 19)

Check that the telectrolyte level is between the upper and the lower level. Add distilled water as required.

⚠ DANGER

Be carefull when maintaining the battery. Avoid flames, and sparks. Always wear gloves and glasses. Wash with water if you are hit by electrolyte.

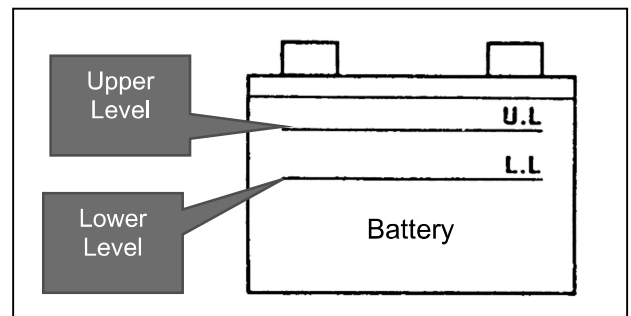

Figure 19

Blade and blade holder condition

Check that the rotary blades are in a good condition, change worn or damaged parts.

How to replace blades :

1. Remove the Blade by loosening the Hard Lock Nut.
Remove the Upper nut, and then remove the Lower nut.
2. After changing a new Blade (or to the reversed blade)
It also should be changed to a new Blade Bolt, Hard Lock Nut and Nut Guard as shown by Figure 20.

⚠ CAUTION

The cutting blade can cut user's hand. You can be cut and injured by cutting blade. Always wear gloves when holding blades.

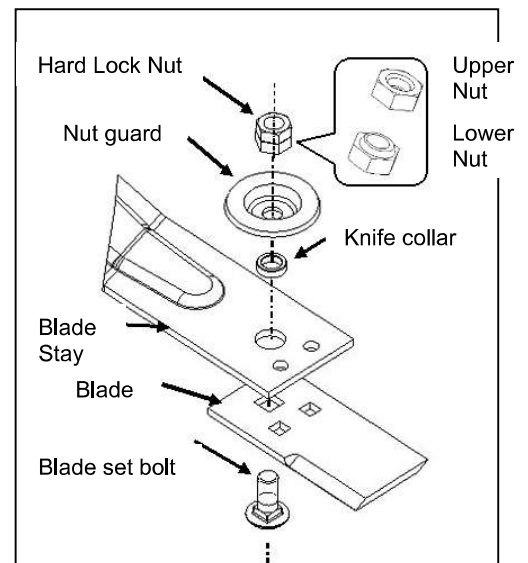
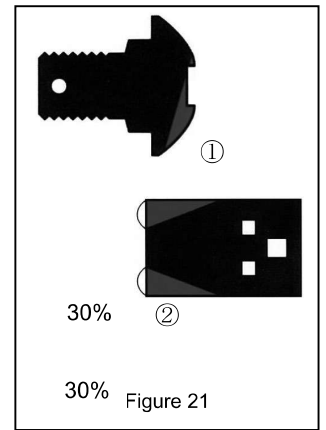

Figure 20

CAUTION

Only use the OREC original parts : “ non genuine ” parts will not assure you of a correct and safe working. It is likely to make the warranty null and void.

- Check the Blade Stay. Even if you do not see any bend or any abrasion on Blade Stay, it should be replaced at every 100 hours or every 2 years of use.
- Please check Blade frequently because it abrades early when you work at a place including dry soil or sand.
- We duly recommend you to purchase a spare Blade and a spare Blade Set Bolt in advance and keep them at your hand.
- When the Blade Set Bolt is worn on its head(1, Figure 21), it can cause a serious accident with the blade thrown away. Replace the Blade Set Bolt immediately when the dent disappeared. Also, Replace(or reverse) the blade when it is worn up to 30% (Figure 21)



Lubrication :

Refer to Figure 22 to lubricate the machine, Do not leave too much grease around the parts, particularly when working in a sandy soil. Clean the grease nipples and lubricate the machine properly (use a grease pump). Only use NLGI N°2 molybdenum bisulphide grease.

GREASE POINT & V BELT LIST		MAINTENANCE	
	①	831/830	SB-31(W800) × 1
		831G/830G	SB-30(W800) × 1
	②	SB-75(W800) × 1	
③	④	GREASE POINT	

0316-78100

Figure 22

Air filter

Loosen the wing nut A, then remove the air filter_(Figure 23). Blow the cartridge with low air pressure from the inside to the outside opposite to the normal air flow. Change the cartridge if it is too dusty or after some cleaning. Clean the foam with water and soap, dry it and oil with engine oil. Press it to remove the oil in excess without squeezing it.

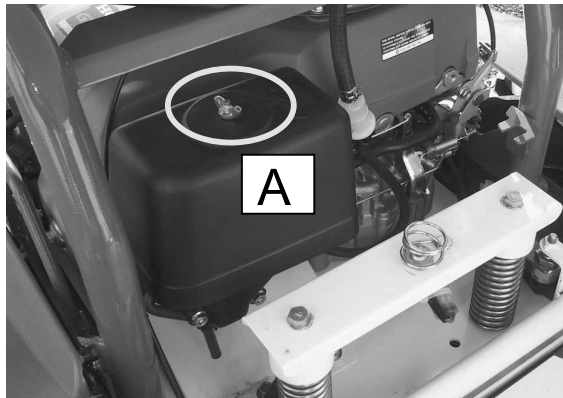

Figure 23



Figure 24

IMPORTANT

Do not blow at big pressure, and maintain a safe distance between the air nozzle and the cartridge to avoid damage on it

Engine:

Refer to the engine manual delivered with the machine.

Oil level: check that the oil level and the engine is not hot by unscrew the gauge A (Figure 25). The oil must be between the two marks “on the stick”. Drain the oil by the screw B.

Engine Oil: “SAE 10W30” or “API SL class”

Oil Quantity: 1.10L

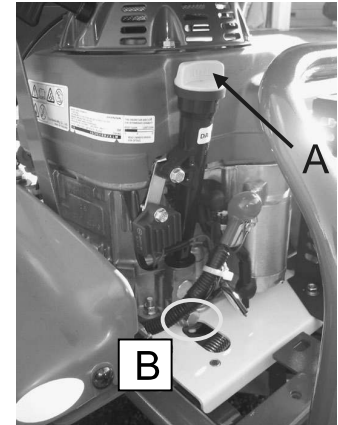

Figure 25

Fuel filter

Check for water and dust in the fuel cartridge filter cock (C, Figure 26). Clean if needed the filter inside the fuel cock. Replace the filter if it is dirty.



Figure 26

Belt tension

Check for belt condition. If they are worn or cracked, change by new one. (Figure 27)

- If the blade brake tension is not enough, move the adjust nut in the direction of “A”
- If the blade brake tension is too tight, move the adjust nut in the direction of “B”

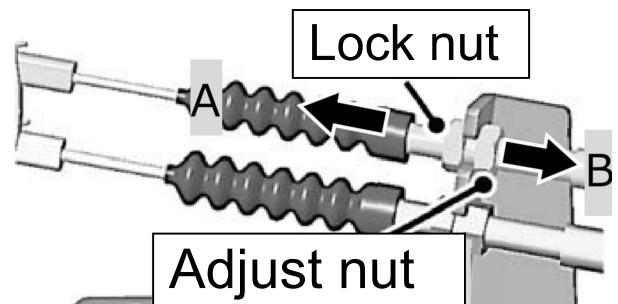

Figure 27

IMPORTANT

A bad tension belt makes sleeping and working out very quickly. A too high tension of the belt will damage the bearings.

Brake

If the brake is not worked efficiently, tighten it with the nut (B, Figure 28 / RM83G, C Figure 12b / RM830).

Tightening bolts

Check that the bolts, nuts...are properly tightened. The vibrations tend to loosen the bolts.

Adjust safety switches

Ajust the screws for pushing the safety switches so they can push switches from 3 to 5 mm.

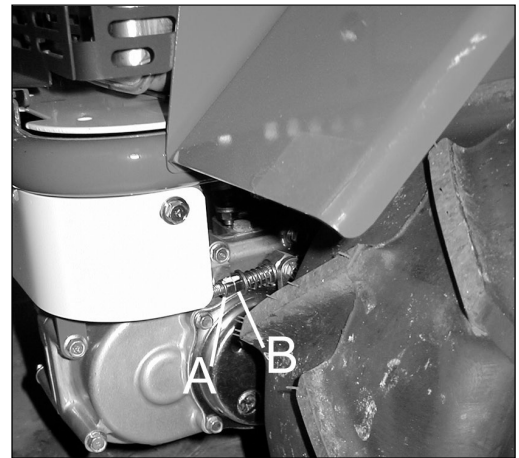

Figure 28

Speed lever adjustment

Ajust the control link (A, Figure 29) in order to have the machine staying still when the lever is at neutral.

DIFF LOCK LEVER ADJUSTMENT

Ajust the control wire (B, Figure 29) until the lever has a free play of 1 to 3 mm before activate the diff lock.

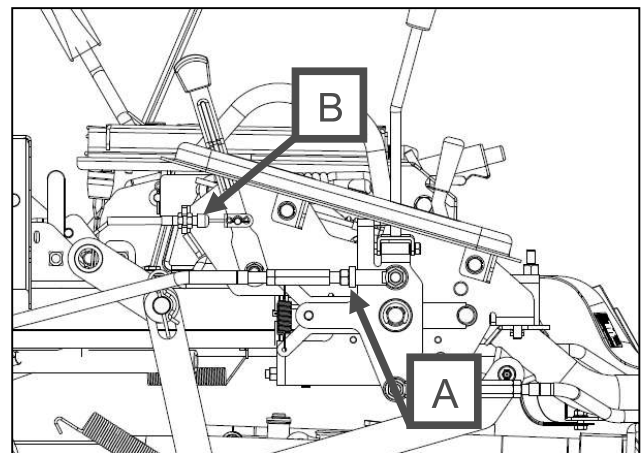

Figure 29

MAINTENANCE CHART

- Ask your dealer to realize this operation needing special tools and knowledge.
- ⊕ Inspection to realize by the owners before starting the engine
- ⊗ Inspection to realize by the owners after starting the engine

Part to inspect	Inspection	Every use	first 20 hours	Every les 100 hours	Every 300 hours every year
Blade belt	Check belt tension		<input type="checkbox"/>	<input type="checkbox"/>	
	Check wear		<input type="checkbox"/>	<input type="checkbox"/>	
HST Transmission	Oil level	⊕		⊕	
	Oil leak	⊕		⊗	
	Oil pollution			<input type="checkbox"/>	
Fuel	refuelling	⊕			
	Fuel cock	⊕			
Flammables materials	Clean the machine from flammables matériels	⊕			
Steering wheel	Horizontal, loosness	⊕			
	Latéral loosness	⊕			
Travel lever	check machine do not move when lever is on "N"	⊗			
	Check travel lever goes on "N" when applying brake	⊗			
Tyres	Check tires pressure	⊕			
	Check tires wear	⊕			
Brake	Check efficiency of the brake	⊗			
	Check travel lever goes on "N" when applying brake	⊗			
Chassis	Check for rust, and cracks				
Safety stickers	Check they are in place and in good condition	⊕			
Safety switches	Check for efficiency	⊗			
Guards & shields	Check they are bolted in their place and in good condition	⊕			
Ignition key	Check for efficiency	⊗			
Tank and fuel hoses	Check for leaks and good condition Replace if needed	⊕			
Battery	Check level	⊕			
Throttle lever	Check for efficiency	⊗			
Blades	Check they are bolted in their place and in good condition	⊕			
Blade clutch control lever	Check the adjustment of the wire	⊕	<input type="checkbox"/>	<input type="checkbox"/>	
Blade brake	Check the adjustment	⊕	<input type="checkbox"/>	<input type="checkbox"/>	
Blade belt	Check they tensionned and in good condition		<input type="checkbox"/>	<input type="checkbox"/>	
Engine	Refer to engine manual				

BREAKDOWNS AND SOLUTIONS

PROBLEME	CAUSE	SOLUTIONS
Engine does not start	No fuel	Refuel the tank
	Battery is empty	Load or replace the battery
	Safety switches are working	Check brakes, blade clutch and seat and Speed lever
The machine does not travel	Parking brake is locked	Unlock parking brake
The machine does not stop	Speed lever is not on « N »	Move the Speed lever to « N »
The blade does not rotate	Blade clutch lever is not engage	Engage Blade clutch lever
	Safety switches are working	Check brakes, blade clutch and seat and Speed lever

TIGHTENING TORQUES (Nm)

DIAMETER OF THE SCREW (mm)	MARKS ON THE SCREW HEAD				
	4 Or without mark	7	8	9	11
3	0,3 to 0,5	---	---	---	---
4	0,8 to 1,0	---	---	---	---
5	2,5 to 3,4	5,4 to 6,4	6,4 to 7,4	6,4 to 7,4	8,8 to 9,8
6	4,9 to 6,9	9,8 to 11,8	11,8 to 13,7	11,8 to 13,7	14,7 to 16,7
8	11,8 to 16,7	24,5 to 29,4	29,4 to 34,3	34,3 to 36,2	36,3 to 41,2
10	20,6 to 29,4	39,2 to 44,1	49 to 53,9	49 to 53,9	72,6 to 82,4
12	44,1 to 53,9	83,4 to 93,2	93,2 to 107,9	93,2 to 107,9	122,6 to 137,3
14	63,7 to 78,5	117,7 to 132,4	132,4 to 147,1	147,1 to 166,7	205,9 to 225,6
16	88,3 to 107,9	152 to 171,6	176,5 to 196,1	215,8 to 245,2	313,8 to 343,2
18	117,7 to 137,3	205,9 to 235,4	245,2 to 274,6	313,8 to 343,2	441,3 to 470,7
20	147,1 to 166,71	235,4 to 274,6	313,8 to 353	441,3 to 480,5	617,8 to 657,1
22	176,5 to 205,9	421,7 to 451,1	539,4 to 578,6	608 to 647,2	843,4 to 882,6
24	235,4 to 264,8	539,4 to 568,8	706,1 to 745,3	784,5 to 823,8	1098,4 to 1137,6

EC CONFORMITY DECLARATION

Business name and full address of the manufacturer: OREC CO., LTD. 548-22
HIYOSHI HIROKAWA-MACHI
YAME-GUN FUKUOKA JAPAN

owner of the technical documents: S.A.T. sarl - Force 7 – ZA –
38110 ROCHETOIRIN France

Designation: brush cutter

Mark: OREC

Conforms to directives: 2000/14/EC, 2006/42/EC, 2014/30/UE

Notified body n°0088: Lloyd's Register Quality Assurance
71 Fenchurch street London EC3S 4BS UK

Harmonized standards used: EN 12733:2018, EN ISO 14982-2009,
EN ISO 3744-2010, EN ISO 3746-2010,
EN1032-2003+A1-2008, EN ISO 20643:2008+A1:2012

Type		RM83G	RM830
Engine	manufacturer	HONDA	HONDA
	type	GXV390	GXV390
	power	7.6kW	7.6kW
Width of cut		820mm	820mm
Conformity assesment 2006/42/EC Annex VIII	measured acoustic power level	98.7dB(A)	100.7dB(A)
	granted acoustic power level	99dB(A)	101dB(A)
Conformity assesment 2000/14/EC Annex V	acoustic pressure level at operator's ears	88.6dB(A)	89.8dB(A)

made at : Fukuoka, 1 July 2022

Signed : Haruhiko Imamura
Function : Managing director



MEASUREMENT OF VIBRATIONS

Mark : OREC

Type	RM83G	RM830
Engine	HONDA	HONDA
	GXV390	GXV390
Accelerometer Position		
100mm from external side of handlebar (Left side)	3.30 m/s ²	3.75 m/s ²
100mm from external side of handlebar (Right side)	2.45 m/s ²	3.54 m/s ²
on the operator seat (Cobo seat)	3.05 m/s ²	1.69 m/s ²

SERIAL NO.
MODEL